

Brio®

Soft Close 120SCT for panel weight 40-120kg



Pack Contents:

- 1x Body Assembly
- 1x Catch Plate Assembly
- 1x Screw 8Gx1/2"
- 1x Screw M5x16 Hex
- 1x Allen Key 3 & 4mm

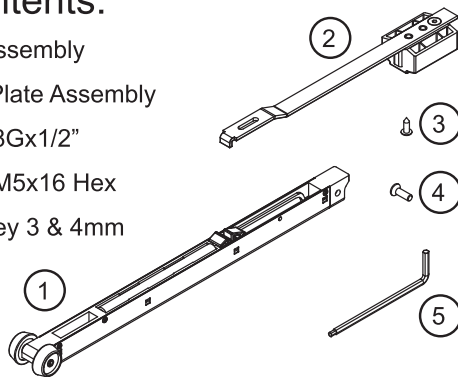

1. Hanger & Soft Close assembly

- (a) Insert the Hanger into the Body assembly and align holes.

57/58/61JNP
Hanger purchased
separately

- (b) Thread the M5 screw using the Allen Key.

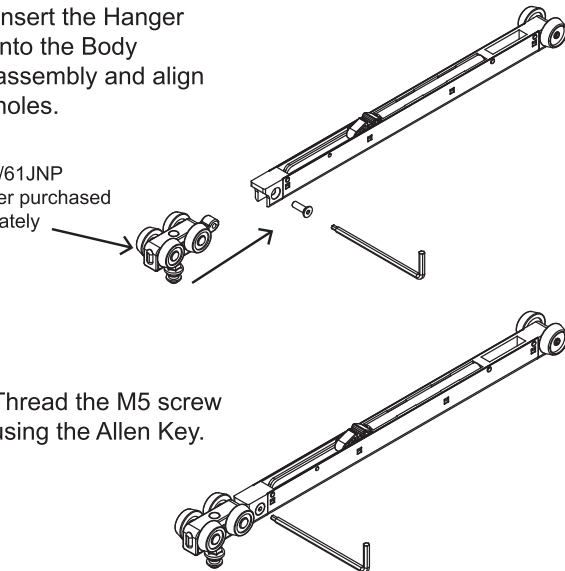

2. Hanger Assembly

- (a) Assemble Body and Hanger assembly into the track.

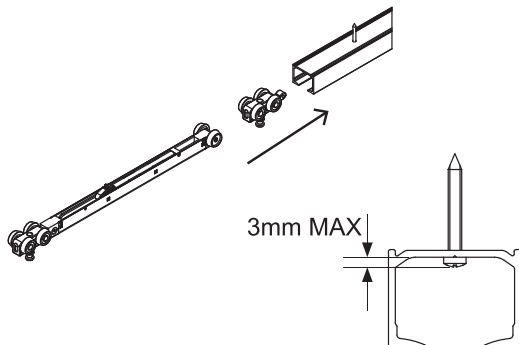

- (b) Ensure that all components are in the correct direction.
(Soft close direction in the diagram below is from right to left.)

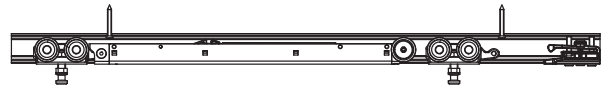

3. Fix Catch Plate into the track.

- (a) Insert the catch plate into the track and secure by tightening the 2 screws.

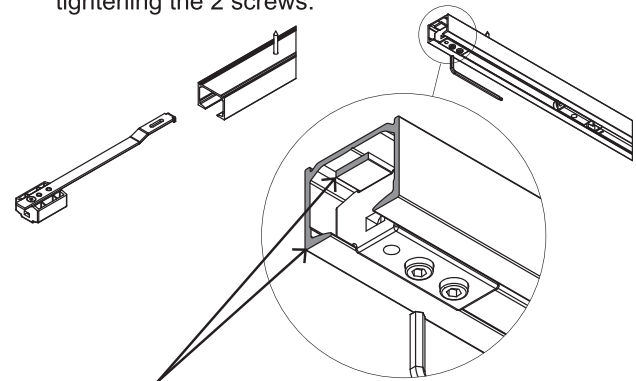

- (b) Ensure the end of the plate and the end of the track are aligned, (shown in grey).

3. Fix Catch Plate.

- (a) Drill the pilot hole in the track using the slot as a template.

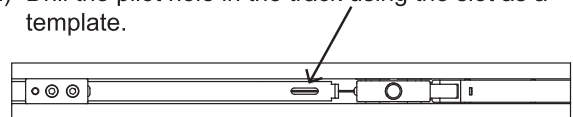

- (b) Fix the the catch plate using the 8G screw.

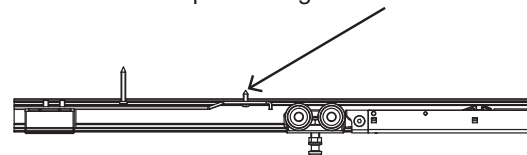

4. Attach Panel to Hanger

- (a) Carefully attach the Panel to the Hanger. Refer to the specific Hanger instructions.

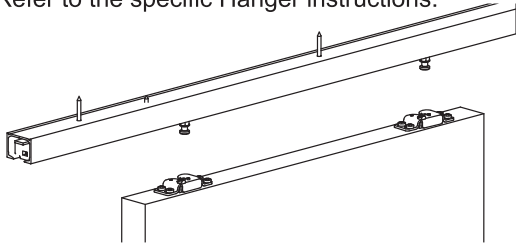

- (b) Adjust the height to make sure the clearance between panel and track are in specification as shown below.

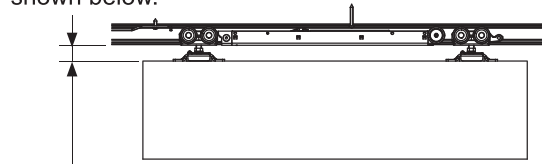

Clearance between track and panel.		Hanger		
		57JNP	58JNP	61JNP
Track	120C	24-30mm	14-20mm	7-13mm
	120F	24-30mm	14-20mm	7-13mm
	120E	22-28mm	12-18mm	5-11mm

WARNING

The 58JNP hanger is factory set with a minimum clearance which is less than the clearance required for soft close. Failure to adjust could result in damage to the catch plate and hanger.

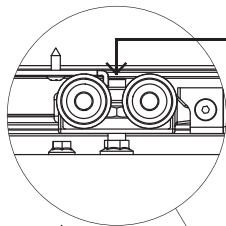

This bolt will hit the catch plate if not adjusted as specified.

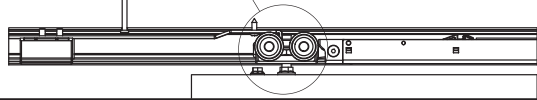

5. Prime the Soft Close

- (a) Slowly move the panel in the closed direction until hearing a click sound.

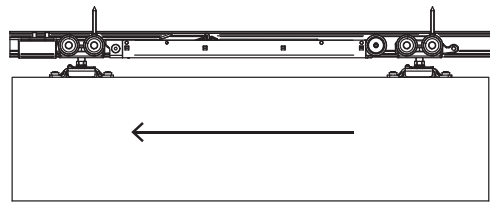

- (b) Slowly move the panel to the open position and the soft close should be primed and ready for use.

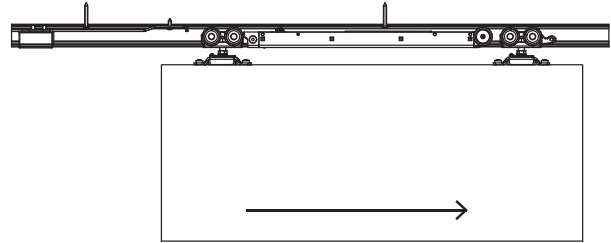

6. Fine adjustment of the gap between the panel and the jamb.

- (a) The gap between the panel and the jamb when the panel is closed should be 3mm.

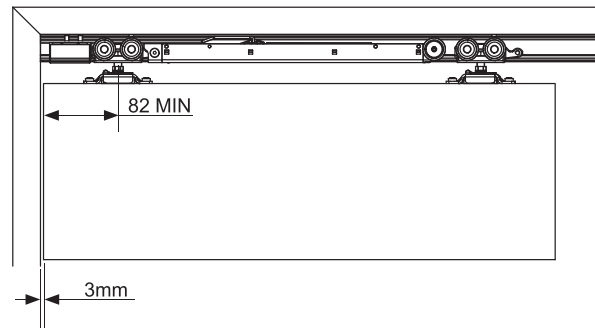

- (b) Adjust the position of the Catch Plate as necessary to achieve the 3mm.

Care and Maintenance

General

Inspect all fixing bolts for tightness every six months, including those securing brackets. Tighten if necessary. Routinely check for wear and if excessively worn, the part should be replaced.

To help prevent surface corrosion, wash regularly with soap or mild detergent and warm water followed by rinsing with clean cold water and wipe dry.

Track

Keep track free from obstruction and excessive dirt or water. Visible surfaces should be cleaned using a damp cloth and mild detergent, then wiped dry.

Hangers

All hangers are fitted with lubricated ball-bearings, requiring no greasing. If doors 'settle' and door clearance is reduced causing friction, raise the door by the hanger adjustment nuts. Wash as per the above recommendation and apply a light application of corrosion preventative to all surfaces, using a dry cloth to remove excess.

Guides

Guide roller and guide channel must be kept clear and free of obstructions. Wash as per the above recommendation and apply a light application of corrosion preventative to all surfaces, using a dry cloth to remove excess.

Allegion (Australia) Pty Ltd
 Freephone: 1800 098 094
 Email: auinfo@allegion.com
www.allegion.com.au

Allegion (New Zealand) Limited
 Freephone: 0800 477 869
 Email: nzinfo@allegion.com
www.allegion.co.nz

