



BELLEVUE
ARCHITECTURAL

New for 2021

- NEW: BAC1431 | 3D For Heavy Doors upto 175Kg



CEAM CONCEALED HINGES

Adjustable 3D concealed hinges for hinged doors
100% made in Italy



+61 3 9571 5666



www.bellevuearch.com.au



info@bellevuearch.com.au



[instagram.com/
bellevue_architectural](https://www.instagram.com/bellevue_architectural)

About Bellevue and CEAM



For over 30 years, the name Bellevue Architectural has always been synonymous with providing the latest in designer fittings from the European marketplace that create visual attraction and differentiation without compromising quality, design or affordability.



Bellevue's products have been used all over Australia and New Zealand from small projects through to large (project pricing available). Bellevue's products are designed and manufactured by people from within the design industry, people who truly believe that design and quality is an integral part of creating something special and unique.



Today Bellevue is proud to represent the CEAM range of concealed hinges. 100% Made in Italy, they are used in a variety of applications. The CEAM concealed hinge is ideal for doors that need to blend into a wall and provide a clean look and feel.

in residential, commercial and industrial environments, CEAM hinges are ideal for front entry doors, kitchen and cupboard doors, office and panic room doors, just to name a few. Ideal for doors that need to cleanly blend into a wall and generate a sophisticated look and feel.

Aesthetically pleasing to the eye as they disappear once the door is closed, CEAM hinges have won international design awards and are used worldwide. Used

Located in Italy & with over 50 years of experience, CEAM is considered a world leader in innovation, design & quality. No other concealed hinge of this type can compete with CEAM's technical product strengths, durability, longevity and cost.



General Information

About CEAM, Raw Materials, S.T.A.R.S, In Situ Hinges

Pg. 4 - 17

Concealed Hinges

BAC2010 (suitable for doors up to 60 kg) - **stainless steel & industrial strength nylon**

Pg. 18 - 19

2D Glass to Wall Adjustable Concealed Hinges

BAC1080 (suitable for Glass doors up to 60 kg)

Pg. 20 - 21

3D Adjustable Concealed Hinges

BAC929 (suitable for cabinets up to 24 kg)

Pg. 22 - 23

BAC1430 (suitable for doors up to 80 kg)

Pg. 24 - 25

BAC1431 (suitable for doors up to 175 kg) **NEW (ideal for heavy doors)**

Pg. 26 - 27

BAC1129 (suitable for doors up to 48 kg)

Pg. 28 - 29

BAC1030 (suitable for doors up to 85 kg) **Stainless steel**

Pg. 30 - 31

BAC1230S (suitable for doors up to 95 kg) **Wide throw designed for Clad Doors**

Pg. 32 - 33

BAC1131S (suitable for doors up to 160 kg)

Pg. 34 - 35

Installation and Accessories

Technical Information

Pg. 36

Jig for door & jambs, routing templates (available to buy or rent)

Pg. 37 - 39

Metal jamb fixing box, cover plate, offset mounting plate, adjustment keys

Pg. 40 - 41

Adjustment Guidelines

Pg. 42 - 43



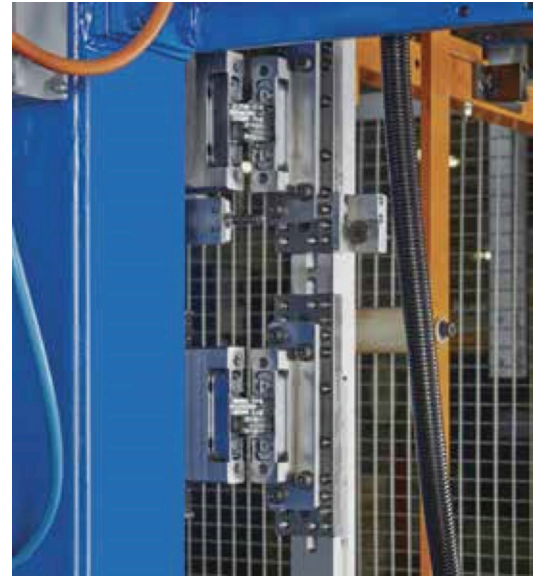

Reliability

The Invisible hinge from CEAM, like all other architectural products, must be mechanically reliable and suitable to allow for the safe on-going movement of the door during its entire life span. The functionality and movement of the hinge must be guaranteed for the long term, well beyond the normal warranty standard.

It is for this expressed purpose; to ensure the highest level of quality control possible, that CEAM's industrial plant, located at Cermenate, Como, Italy is where all stages of production process is undertaken: from design, tool making, through moulding, cuttings and turnings of the best materials, ending with the automatic assembly and logistic department.



DURABILITY	200.000 opening cycles 0 - 90°		Yielding verification
DEFORMATION UNDER LOAD	Door weight double than the hinges load bearing capacity	<ul style="list-style-type: none"> ▪ 5 opening & closing cycles at 0 - 90° ▪ 5 opening & closing cycles at 0 - 180° 	Yielding verification
OVERLOAD	Door weight triple than the hinges load bearing capacity	Open at 90° for 60 minutes	Yielding verification
FRICITION TORQUE	Door weight as per the hinge load bearing chart	30 opening & closing cycles at 0° - 90°	Friction check every 30° up to 180°

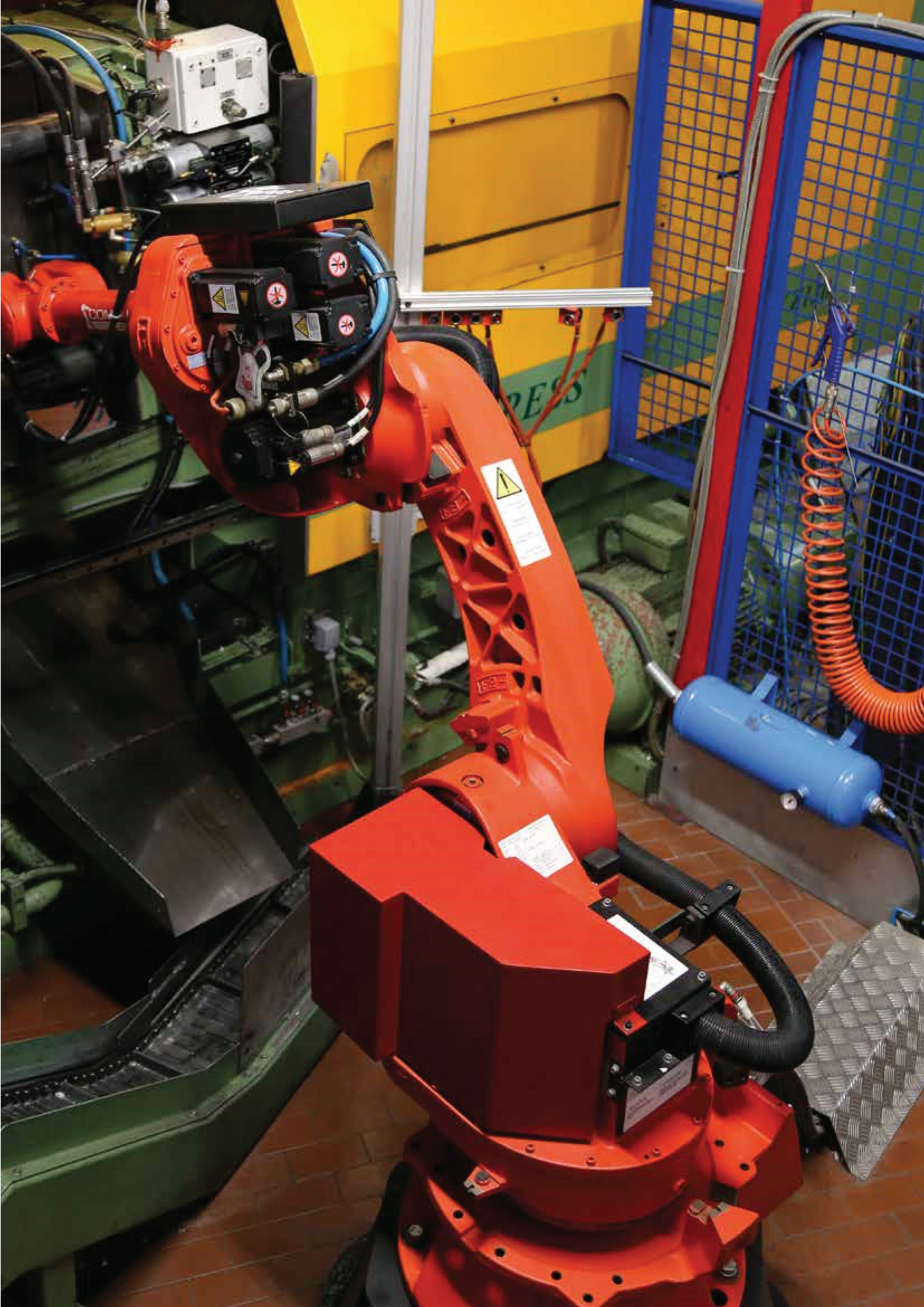

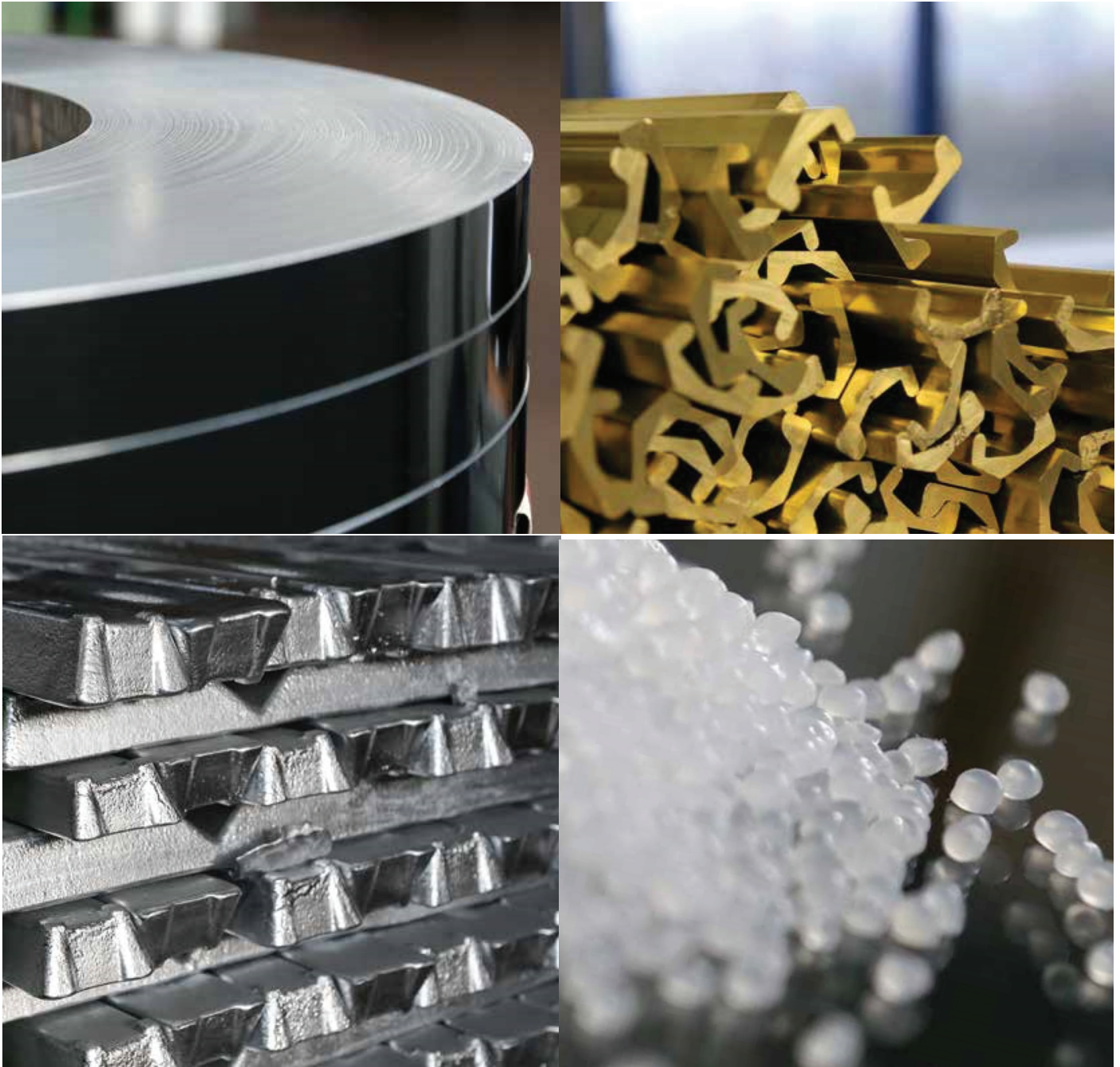

Raw Materials.

STEEL:

Iron-based alloy, which contains a variable percentage of carbon in the range of 0.1% ÷ 2%.

Steel is one of the most widely used materials in the world for its strength, complete recyclability, high mechanical resistance, pliability and elasticity. Furthermore, it can gain mechanical resistance and toughness through repeated tempering.

BRASS:

Copper-based alloy, which contains a percentage of zinc in the range of 36% ÷ 45%, and other elements like magnesium, tin and aluminium that enhance resistance to corrosion, and iron that increases ultimate strength. Mechanical features, weathering resistance and excellent malleability make brass the ideal choice for several applications. Brass can be easily used for galvanic surface plating; hence, it is extensively adopted for products that require plating.

ZAMAT:

Zinc-based alloy, which contains a percentage of aluminium in the range of 3% - 5%, and a percentage of copper in the range of 1% - 3%. It can be used for pressure die castings to obtain items with complex shapes and low dimensional tolerance. It can be adopted for any galvanic treatment.

NYLON:

Commercial name: Polyamide PA6/66.

It is a thermoplastic material that has high mechanical resistance, excellent toughness and high resistance to impact. With excellent resistance to wear and anti-effraction properties, it is extensively used for many technical purposes. Almost transparent when raw, it can be produced in many colours.

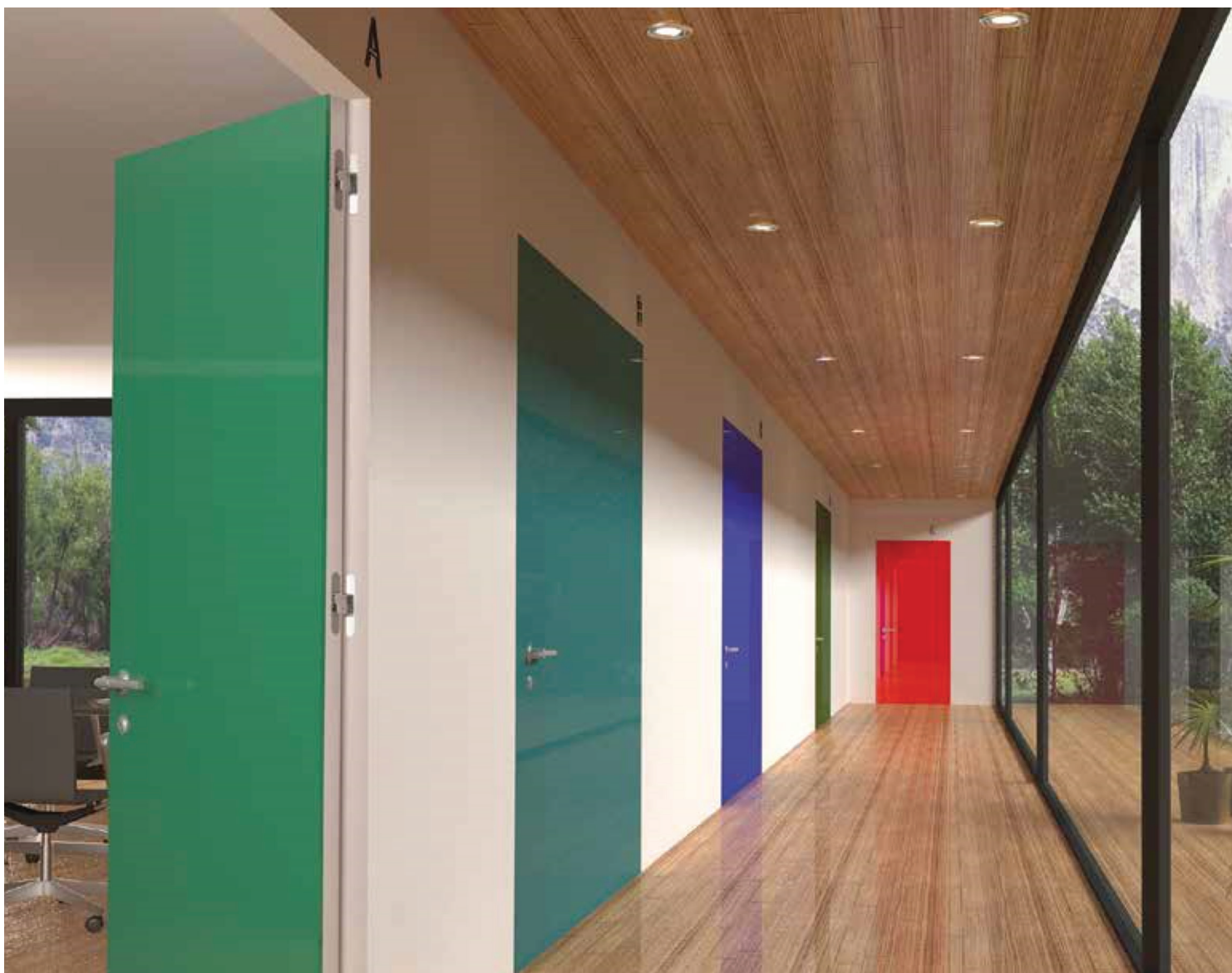

S.T.A.R.S. 

S.T.A.R.S. Series features

A hinge system with three independent adjustable axes

- Fluid 180° opening
- The innovative patented system with internal sliding, reduces the hinges depth to a minimum of 18 mm "BEST IN CLASS"
- Minimum door thickness: 18 mm
- Minimum doorjamb thickness: 15 to 29 mm
- Manufactured in 3 different base materials: Die-Cast, Stainless Steel and Nylon
- Complete reversibility thanks to the perfect symmetry of the two hinge sides (same slot on the door and the jamb)
- Totally recessed hinge body: the gap between door and jamb is significantly small
- Easy installation: the door part and the jamb part can be assembled separately in production and united on-site
- Elegant minimalistic design thanks to multiple finishes
- Cover plates in durable galvanized steel
- Ideal for: wooden doors, aluminium, iron, rebated, flush doors, folding doors, closets, furniture, galley and... much more
- Quality: 100% Made in Italy, tested to 200,000 cycles of opening harmonizing the UNI EN 1935
- Fire rated by LAPI certificate UNI EN1634-2 (Highest in European standards)







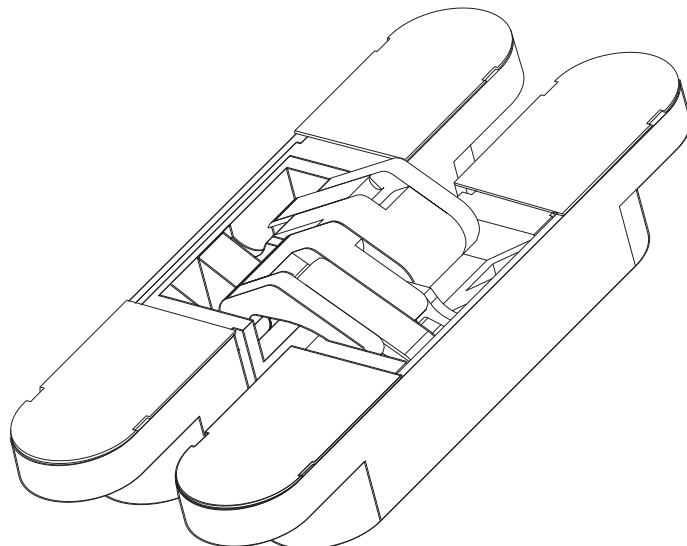











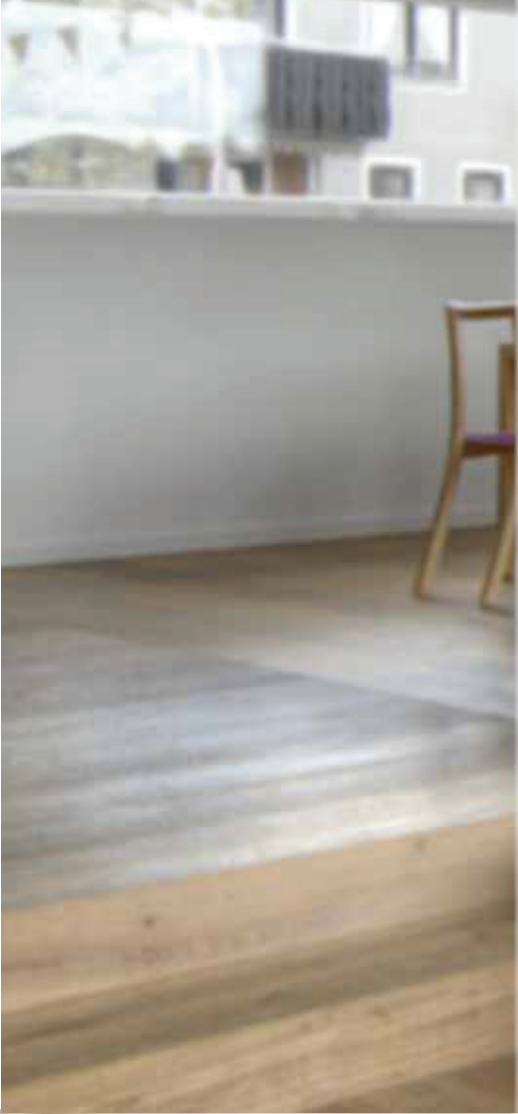

Concealed Hinge BAC2010 Technical Data

304 Grade Stainless Steel & Industrial Nylon: Max 60kg

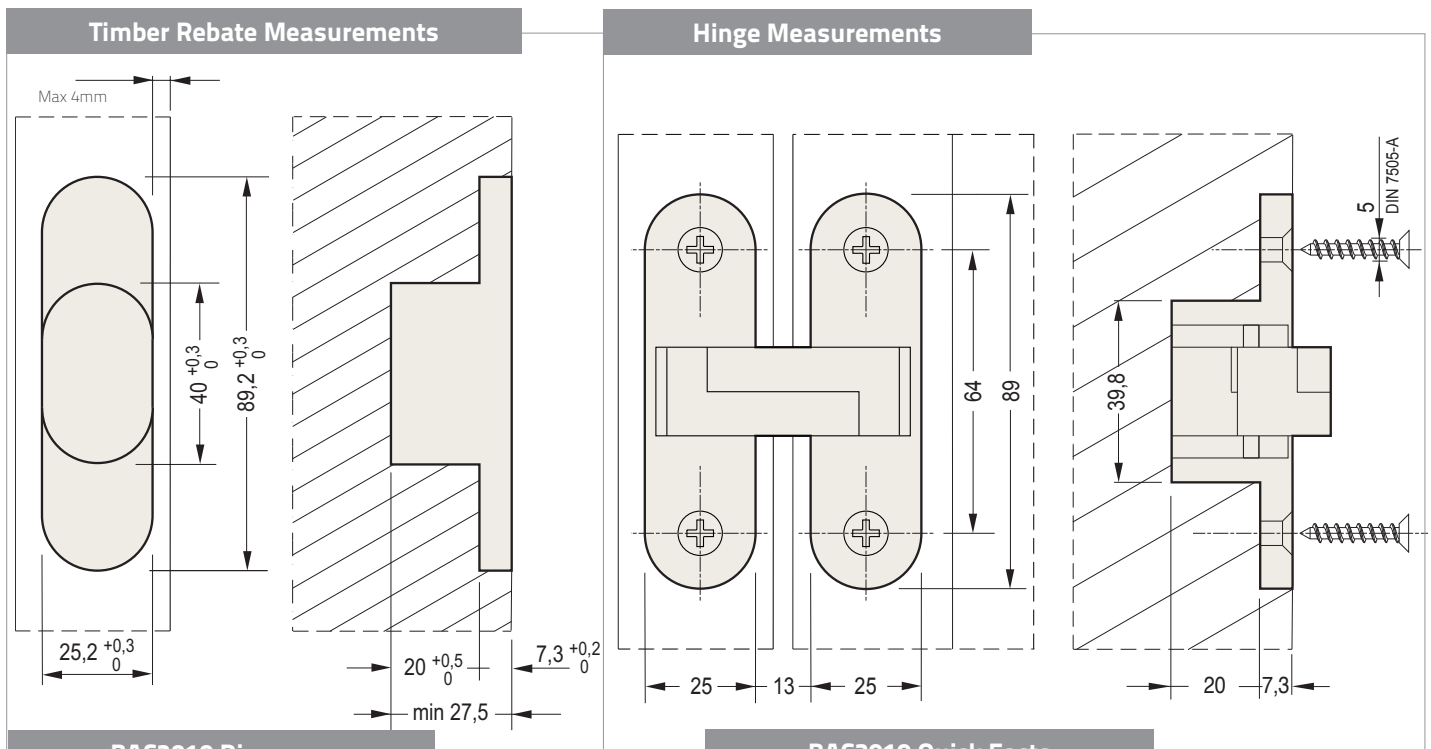

BAC2010 Diagrams

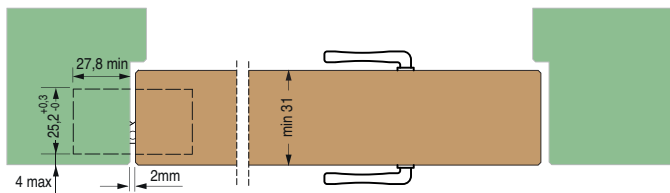

Hinge rebated 4mm max from edge of door and jamb on opening side

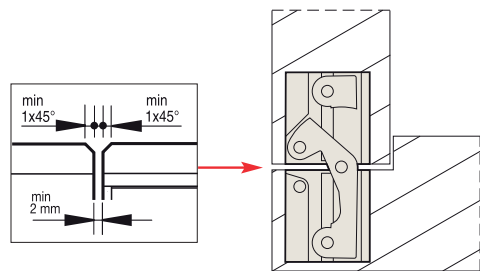

Min 2mm gap between door and jamb

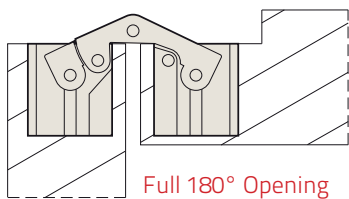

BAC2010 Quick Facts

- 100% Made in Italy for over 50 years
- Suitable for high frequency opening doors
- Available in Satin Stainless or Polished Brass
- Jig & router template available for easy installation
- Made from industrial strength nylon & stainless steel
- Suitable for internal & external (under cover) locations
- Suitable for residential, commercial & industrial locations

Note: if being used with a door closer see page 36.

No. of Hinges based on Door Width & Weight

Door width up to 850 mm height up to 2100 mm

- A** - 2 hinges 40 kg Max
- B** - 3 hinges 60 kg Max

Before applying a door closing device, please contact our technical office on +61 3 9571 5666

- more than 2100 mm high**
- C** - Please Call Bellevue

The hinge must be lubricated once a year

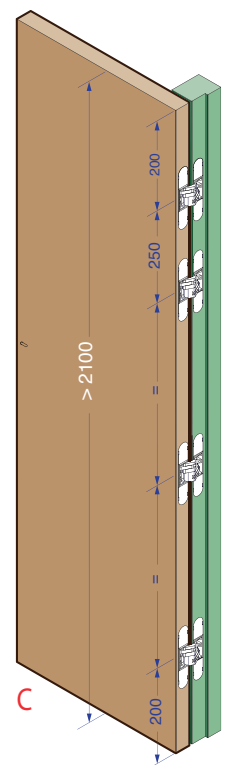
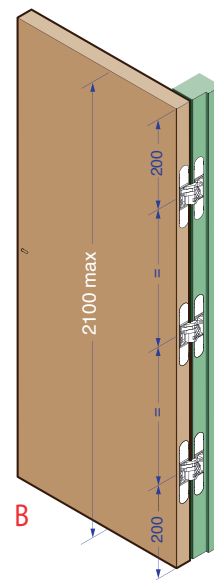
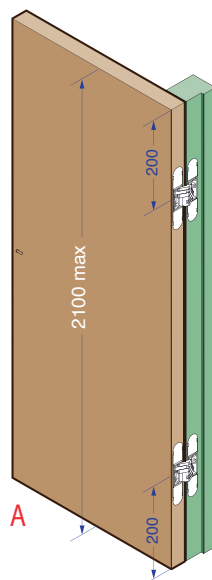

Concealed Hinge BAC2010 Functional Data

304 Grade Stainless Steel & Industrial Nylon: Max 60kg



No need for unsightly butt hinges or pivot kits, the BAC2010 concealed hinge brings a clean aesthetic appeal to a door, allowing it to blend into the wall.

Made 100% in Italy by CEAM, the BAC2010 is reliable, completely invisible (when the door is closed) and ideal for doors that weigh up to 60kg.

Designed to allow a door to open and close, as would any other hinge, but with one difference; you don't see it. Made out of stainless steel and industrial strength nylon, the BAC2010 hinge is ideal for internal

or external (under cover) applications. Rated to carry a 60kg door to 90° or 180° opening, the hinge is extremely versatile and reliable as it is rated to 100,000 opening and closing cycles.

Once installed the BAC2010 hinge becomes totally invisible when the door is closed, providing a clean, sophisticated blended door to wall look.

Unlike traditional hinges where the two leaves of the hinge meet and protrude out past the jamb and face of the door, the BAC2010 hinge is hidden away by the door

jamb and the door which butts up against each other when the door is closed, with only a minimum 2mm gap.

An added advantage of the BAC2010 is its appearance; aesthetically pleasing to the eye when the door is open, it is sleek and has clean lines.

Cost effective and highly functional, it is a real and effective alternative to traditional and unsightly butt hinges and pivot systems. It's guaranteed for 100,000 cycles and is available in two finishes; the CEAM BAC2010 is hard to overlook.

304 Stainless Steel & Nylon
Ideal for internal & external use

BAC2010 Quick Facts	
Min. door thickness	31mm
Max. door weight	60kg
Narrow rebate	27.5mm
Gap when closed	2mm
Working aperture	180°
Manufacturing location	100% Made in Italy
Reliability	Certified to over 100,000 cycles



BAC2010 Order Codes	
BAC2010SS	Satin Stainless
BAC2010PB	Polished Brass with Stainless knuckle
BACJIG-BACT2010	Jig & hinge template (rent or buy) pg. 37 - 39

2D Concealed BAC1080 Glass Technical Data

Y & Z Adjustable: Max 60kg Glass Door

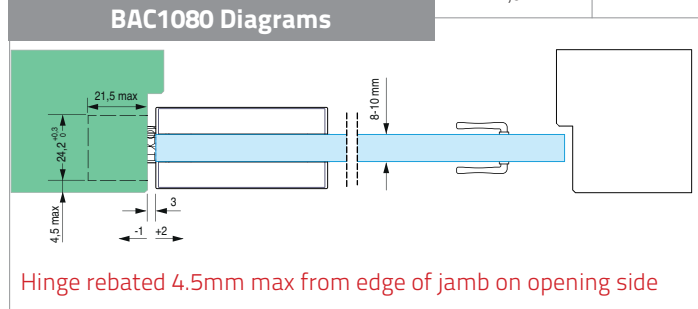
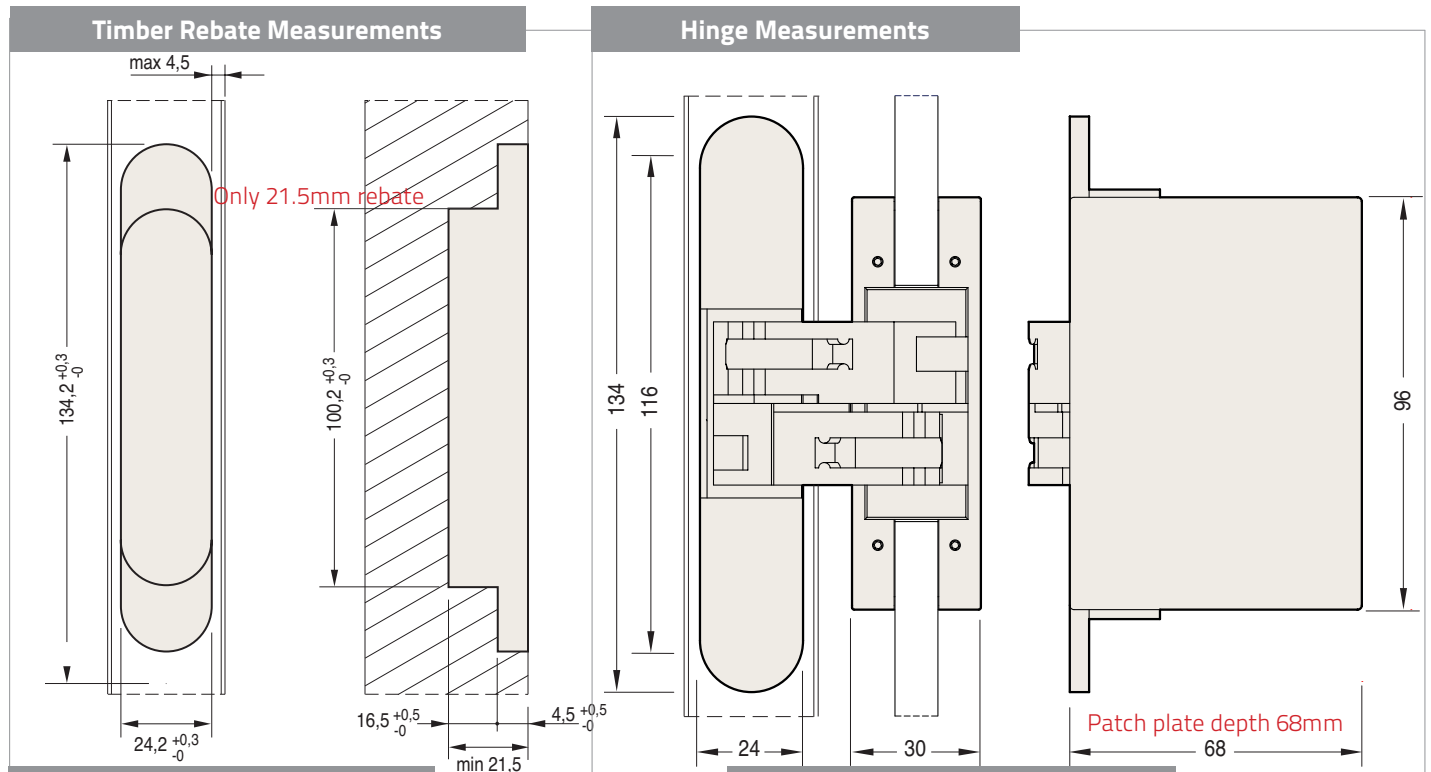
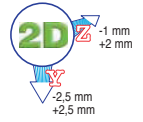

- ### BAC1080 Quick Facts
- 2D adjustable Glass Hinge
 - CEAM quick release system
 - Available in multiple finishes
 - Suitable for glass 8-10mm thick
 - 100% Made in Italy for over 50 years
 - Suitable for high frequency opening doors
 - Jig & router template available for easy of installation
 - Suitable for internal & external (under cover) locations
 - Suitable for residential, commercial & industrial locations
- Note: if being used with a door closer see page 36.**

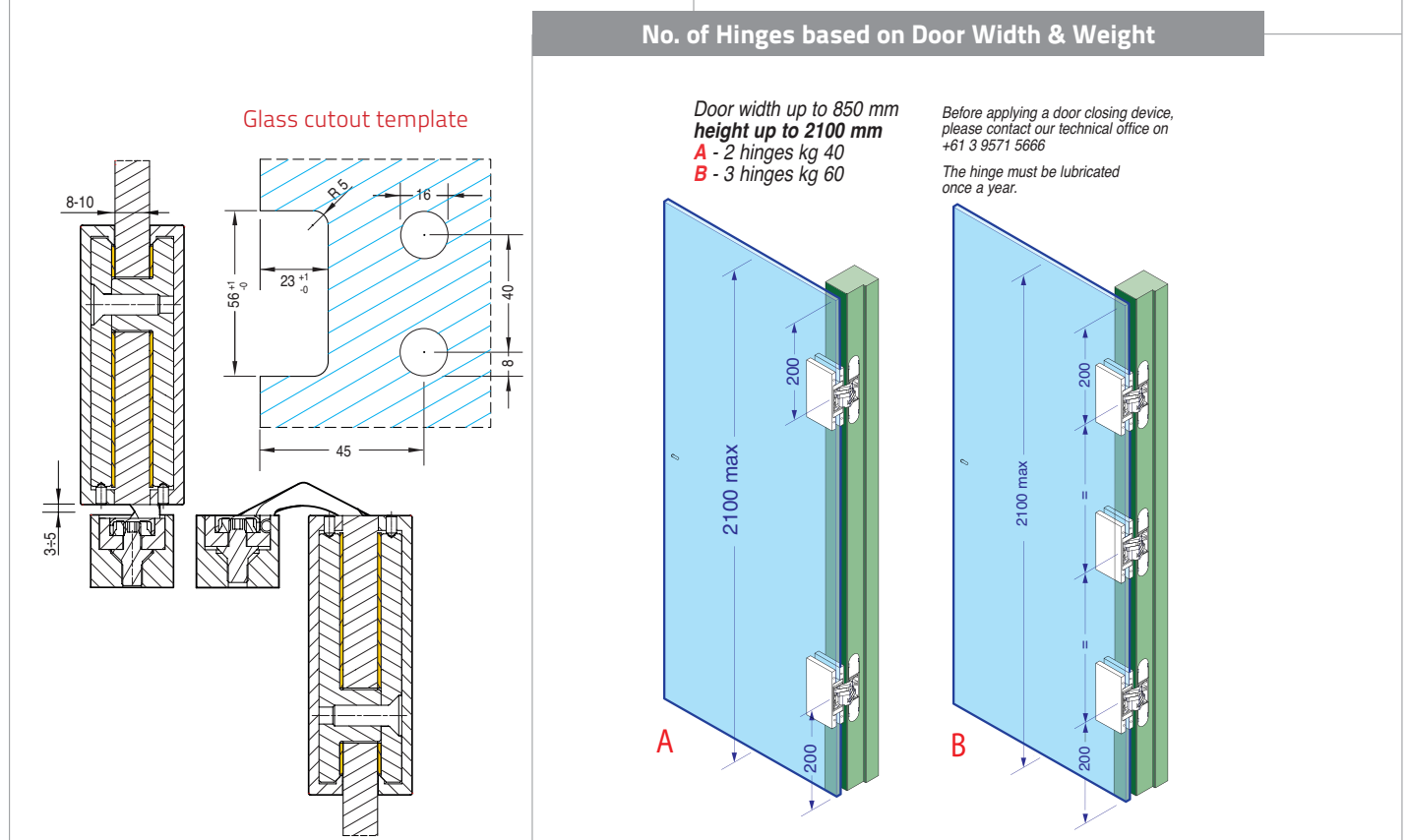

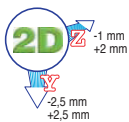

2D Concealed BAC1080 Glass Functional Data

Y & Z Adjustable: Max 60kg Glass Door

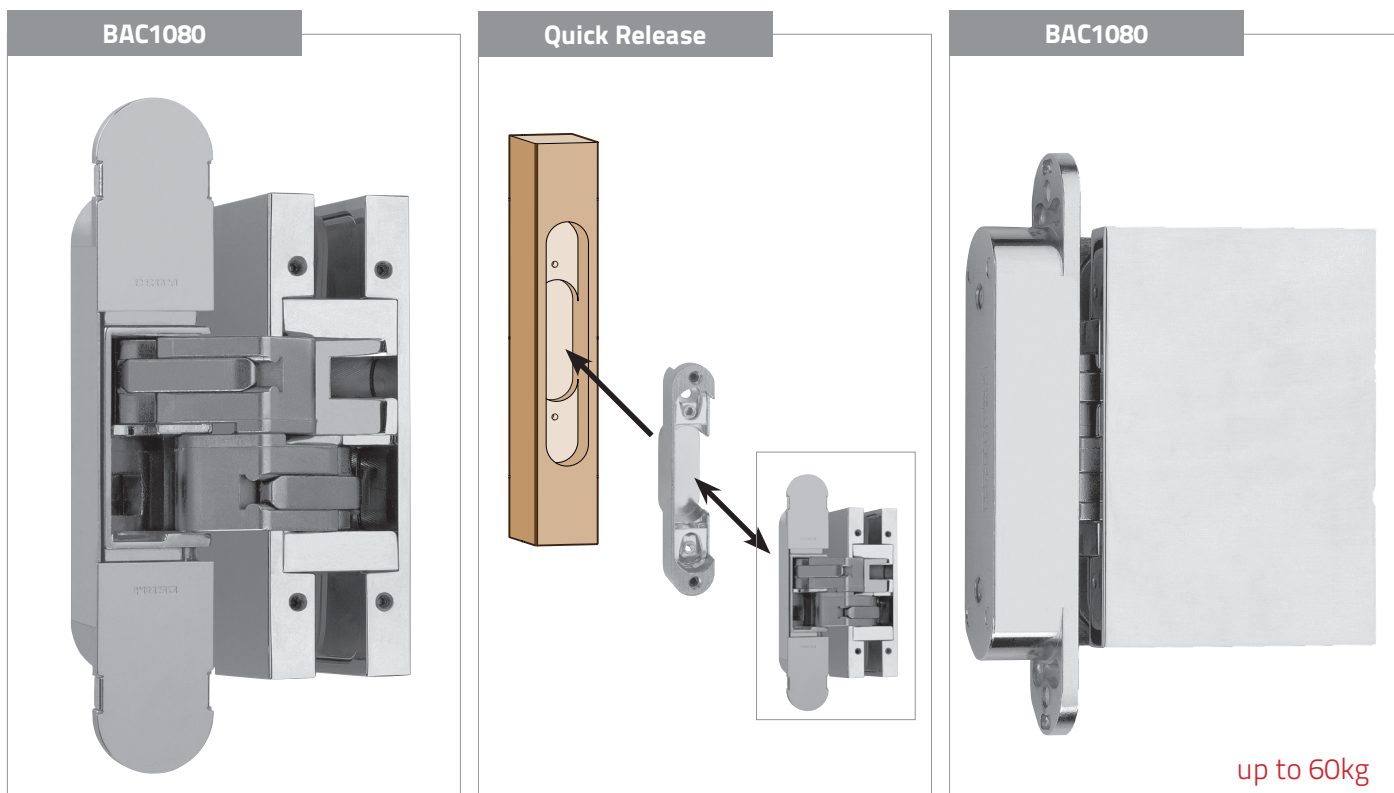

Model for Glass Doors

Specifically designed to butt *glass doors* up against a wall or jamb, the BAC1080 2D adjustable concealed patch plate hinge is rated to hold a 8-10mm thick 60kg glass door. It's revolutionary in it's design by combining a patch plate and invisible hinge together.

Not only can you adjust the position of the glass door in 2 dimensions (up down & left, right) but you can also take the door down without having to remove the hinge from its rebated housing in the jamb or wall.

Patch plate to wall... clean and sophisticated

Rated to carry an 8-10mm thick 60kg glass door to 90° or 180° opening, the hinge is extremely versatile and reliable. Tested to

150,000 opening and closing cycles. Cost effective and highly functional, it is a real and effective alternative to traditional and unsightly glass door hinges and pivot systems.

Quick release: CEAM's quick release system is revolutionary - once installed, you never need touch the jamb again.

The hinge sits within a cup, the cup is rebated into jamb or directly into the wall, the hinge is then fastened to the cup. As a result, if the door needs to come down, all you do is unscrew the locking bolts and remove the hinge from the cup.

The door can be removed and reinstalled for painting and adjustments without

damaging the walls render, timber or paint work, saving time and money.

Door movement: Over time, this can be an expensive problem to fix. Not with the BAC1080 2D adjustable hinge; it specifically caters for door movement.

Once movement occurs, a door may not close properly or rub the paintwork. To fix, the door needs to come down and then the door jamb needs to be planed and repainted; a costly and time consuming effort. Not any more.

Using the BAC1080, simply adjust the position of the door via the settings within the hinge. This adjustment is done without the door coming down.

BAC1080 Quick Facts

Min. glass thickness	8 -10mm
Min. Jamb thickness	30mm
Max. door weight	60kg
Narrow rebate	21.5mm
Gap when closed	3mm
Working aperture	180°
Manufacturing location	100% Made in Italy
Reliability	Certified to over 150,000 cycles
Adjustable	2D adjustment on 2 (Y, Z) axes
Quick Release	CEAM quick release system, never need to touch the jamb again

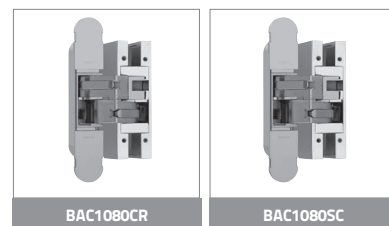

BAC1080 Order Codes	
BAC1080CR	Polished Chrome
BAC1080SC	Satin Chrome
BACJIG-BACT1080	Jig and hinge template (rent or buy) pg. 37 - 39

3D Concealed Hinge BAC929 Technical Data

Fully Adjustable: Max 24kg

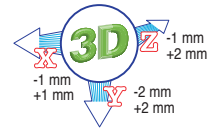

Hinge Depth Measurements

19mm

15mm

Full 180° Opening

Hinge Measurements

5,5 13,5 19

76

68 60

14 7±9 14

9,5 5,5

15

Ø4 DIN 7505-A

BAC929 Quick Facts

- 3D adjustable hinge for cupboards
- CEAM quick release system
- Available in multiple finishes
- 100% Made in Italy for over 50 years
- Suitable for high frequency opening doors
- Jig & router template available for easy installation
- Suitable for internal & external (under cover) locations
- Suitable for residential, commercial & industrial locations

Only 15mm rebate ideal for thin jambs

Only 15mm deep

BAC929 Diagrams

A

B

A

B

Note: if being used with a door closer see page 36.

Cabinet cross-section with door outside the box.

A	B
18mm	2mm
20mm	3mm

Cabinet cross-section with door inside the box.

A	B
18mm	2mm
20mm	3mm

No. of Hinges based on Door Width & Height

- 2 hinges per door
- 3 symmetrical hinges per door
- 4 hinges per door

Door Width (mm)	Door Height (mm)	Weight Capacity (Kg)
700	1000	10Kg
	1200	13Kg
	1800	17Kg
600	1000	12Kg
	1200	16Kg
	1800	21Kg
500	1000	14Kg
	1200	18Kg
	1800	24Kg

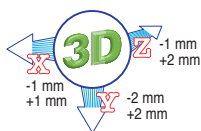

3D Concealed Hinge BAC929 Functional Data

Fully Adjustable: Max 24kg

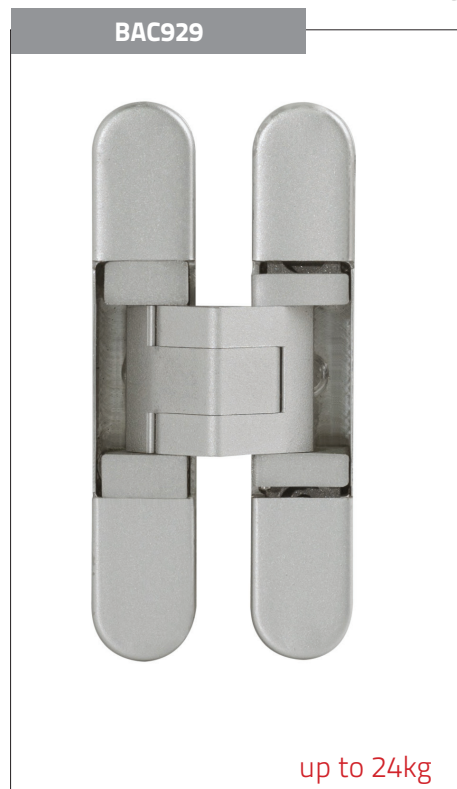
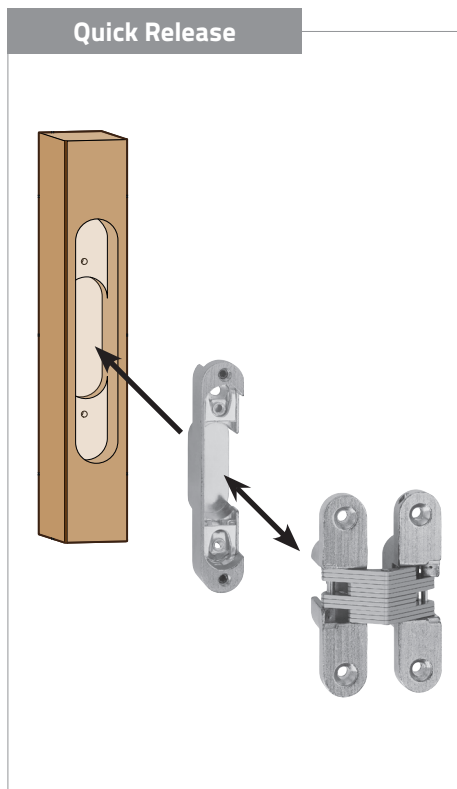

3D Fully Concealed Adjustable Hinge for Cupboards.

The BAC929 3D adjustable concealed cupboard hinge is revolutionary in its design and is rated to carry a 24kg cupboard door to 180° opening aperture.

A blended door to wall look and feel: once closed, the BAC929 hinge becomes invisible, hidden away by the jamb and the door butting up against each other.

Cupboard doors no longer need to be visually interrupted by the traditional butt hinge where the two leaves of the hinge meet and protrude out past the jamb.

The formal architectural composition of a wall can now continue without interruption, creating an aesthetically appealing appearance that is truly clean and elegant.

Quick release: CEAM's quick release system is revolutionary - once the hinge is installed, you never need touch the door or jamb again.

The hinge sits within a cup, the cup is rebated and fixed to the door and jamb, the hinge is then fastened to the cup. As a result, if the door needs to come down, all you do is unscrew the locking bolts and remove the hinge from the cup.

The door can be removed and reinstalled for painting and adjustments without damaging timber or paint work, saving time and money.

Door movement: over time, this can be an expensive problem to fix. Not with the BAC929 3D adjustable hinge; it specifically caters for door movement.

Once movement occurs, a door may not close properly or rub the paintwork. To fix, the door needs to come down and then the door and/or jamb needs to be planed and repainted; a costly and time consuming effort.

Using the BAC929, simply adjust the position of the door via the settings within the hinge. This adjustment is done without the door coming down.

S.T.A.R.S.

BAC929 Quick Facts

Min. door thickness	18mm
Max. door weight	24kg- Subject to Width & Weight Chart
Narrow timber rebate	15mm (ideal for thin jambs)
Gap when closed	2mm
Working aperture	180°
Manufacturing location	100% Made in Italy
Reliability	Certified to over 150,000 cycles
Adjustable	3D adjustment on 3 (X,Y,Z) axes
Quick Release	CEAM quick release system, never need to touch the door or jamb again



BAC929 Order Codes

BAC929SI	Silver
BAC929NI	Polished Nickel
BAC929BL	Black
BAC929WH	White
BACJIG-BAC929	Jig and hinge template (rent or buy) pg. 37-39

3D Concealed Hinge BAC1430 Technical Data

Fully Adjustable: Max 80kg

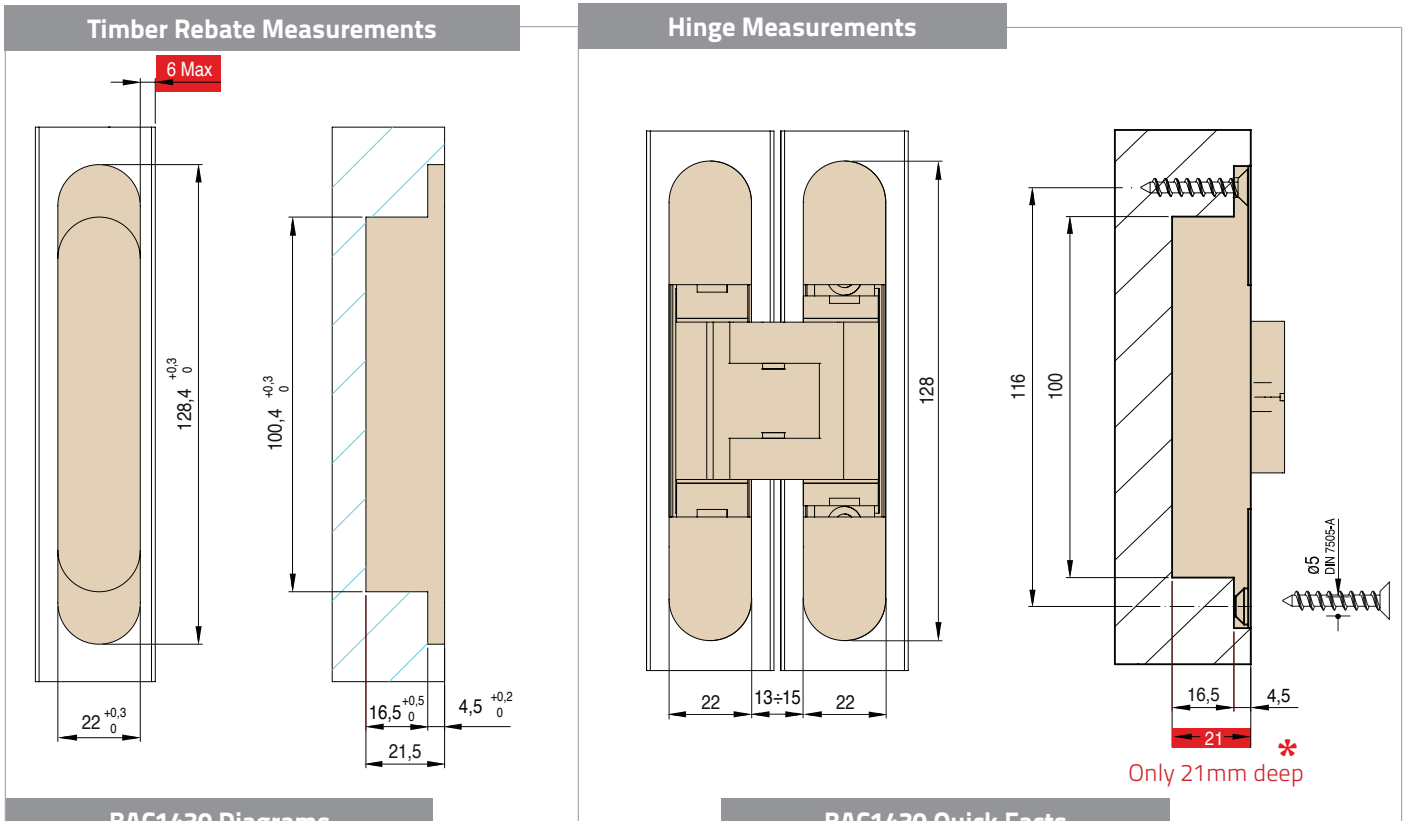
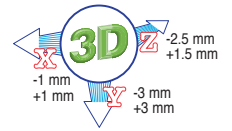

BAC1430 Diagrams

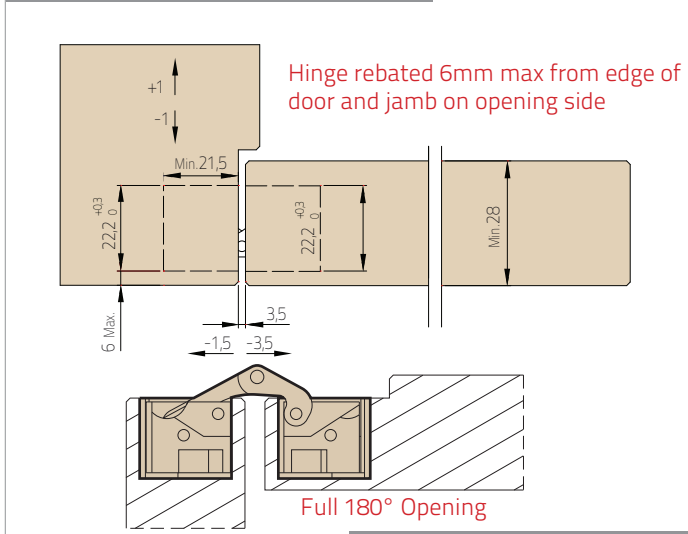

BAC1430 Quick Facts

- 3D adjustable
- CEAM quick release system
- Available in multiple finishes
- 100% Made in Italy for over 50 years
- Suitable for high frequency opening doors
- Jig & router template available for easy installation
- Suitable for internal & external (under cover) locations
- Suitable for residential, commercial & industrial locations

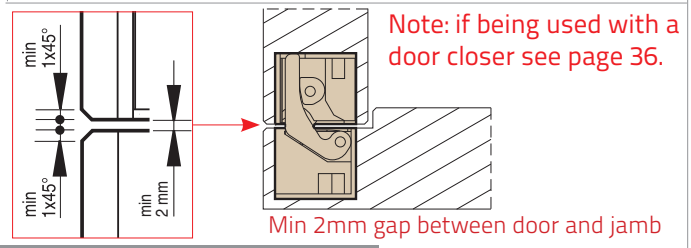

No. of Hinges based on Door Width & Weight

For doors over 2100mm tall, see page 36

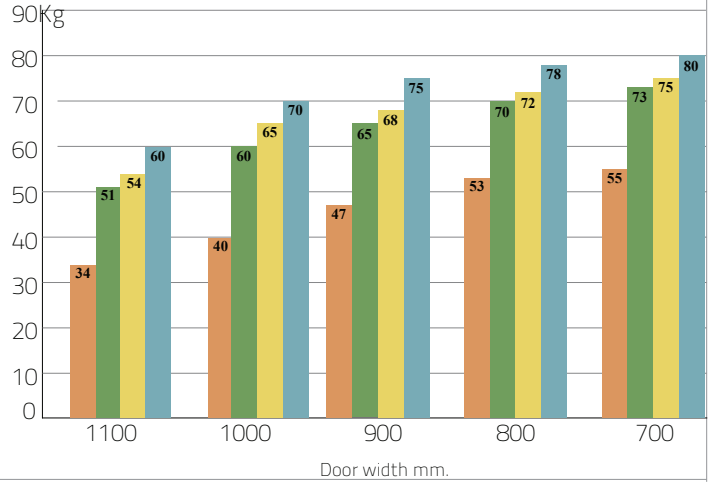
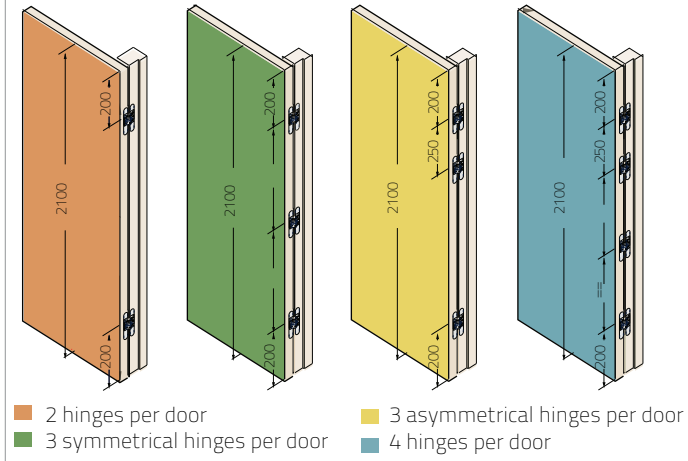

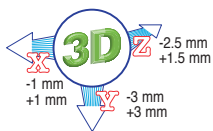

3D Concealed Hinge BAC1430 Functional Data

Fully Adjustable: Max 80kg

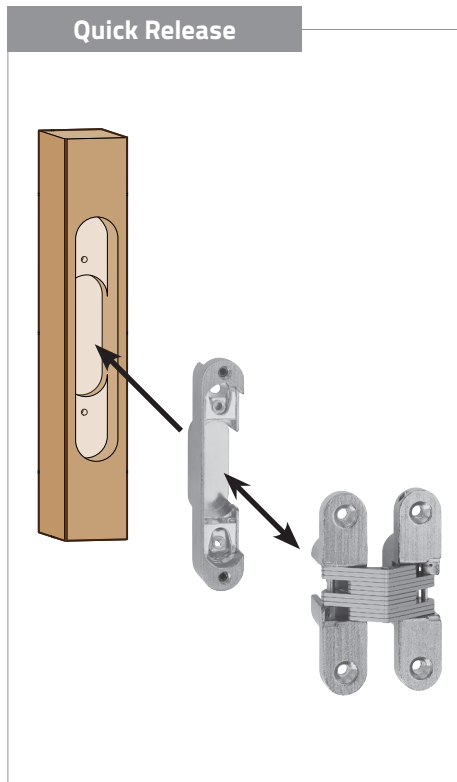

The BAC1430 3D adjustable concealed hinge is revolutionary in its design and is rated to carry a 80kg door to 180° opening aperture.

A blended door to wall look and feel: once closed, the BAC1430 hinge becomes invisible, hidden away by the jamb and the door butting up against each other.

Walls no longer need to be visually interrupted by the traditional butt hinge where the two leaves of the hinge meet and protrude out past the jamb.

The formal architectural composition of a wall can now continue without interruption, creating an aesthetically appealing appearance that is truly clean and elegant.

NEW 3D fully adjustable Concealed Hinge now available in white. Solid Colour Including the knuckle.

Quick release: CEAM's quick release system is revolutionary - once the hinge is installed, you never need touch the door or jamb again.

The hinge sits within a cup, the cup is rebated and fixed to the door and jamb, the hinge is then fastened to the cup. As a result, if the door needs to come down, all you do is unscrew the locking bolts and remove the hinge from the cup.

The door can be removed and reinstalled for painting and adjustments without damaging timber or paint work, saving time and money.

Door movement: over time, this can be an expensive problem to fix. Not with the BAC1430 3D adjustable hinge; it specifically caters for door movement.

Once movement occurs, a door may not close properly or rub the paintwork. To fix, the door needs to come down and then the door and/or jamb needs to be planed and repainted; a costly and time consuming effort.

Using the BAC1430, simply adjust the position of the door via the settings within the hinge. This adjustment is done without the door coming down.



BAC1430 Quick Facts

Min. door thickness	28mm
Max. door weight	80kg- Subject to Width & Weight Chart
Narrow timber rebate	21mm (ideal for thin jambs)
Gap when closed	2mm
Working aperture	180°
Manufacturing location	100% Made in Italy
Reliability	Certified to over 150,000 cycles
Adjustable	3D adjustment on 3 (X,Y,Z) axes
Quick Release	CEAM quick release system, never need to touch the door or jamb again



BAC1430 Order Codes

BAC1430SI	Silver
BAC1430PB	Polished Brass
BAC1430BL	Black
BAC1430WH	White
BAC1430BZ	Bronze
BAC1430SN	Satin Nickel
BAC1430CR	Polished Chrome
BACJIG-BACT1430	Jig & hinge template (rent or buy) pg. 37-39

3D Concealed Hinge BAC1431 Technical Data

Fully Adjustable: Max 175kg

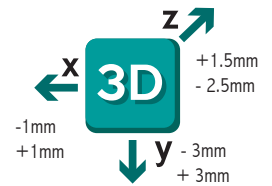

Timber Rebate Measurements

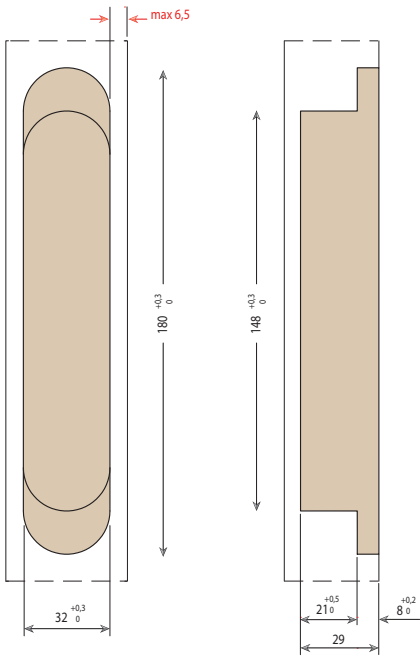

Hinge Measurements

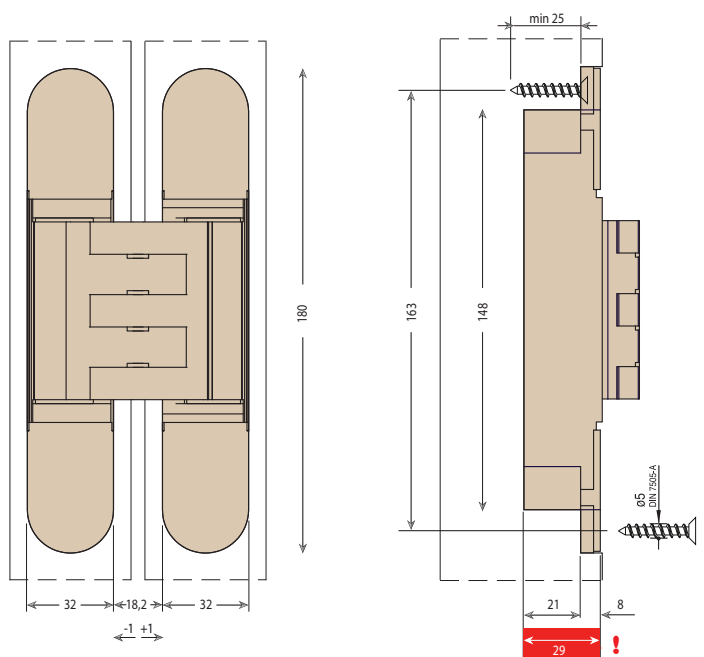

Only 29mm deep

BAC1431 Diagrams

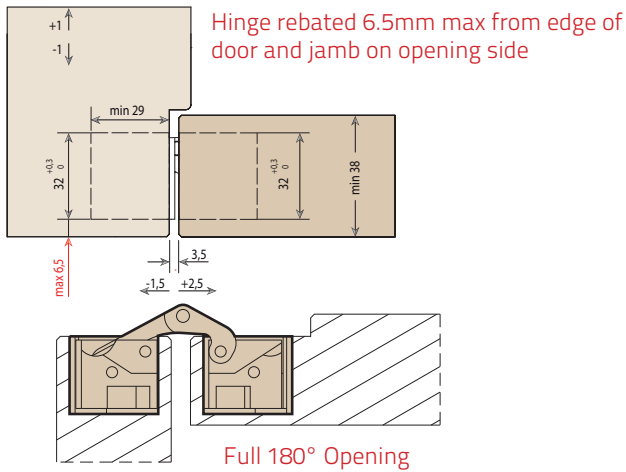

BAC1431 Quick Facts

- 3D adjustable
- CEAM quick release system
- Available in multiple finishes
- 100% Made in Italy for over 50 years
- Suitable for high frequency opening doors
- Jig & router template available for easy installation
- Suitable for internal & external (under cover) locations
- Suitable for residential, commercial & industrial locations

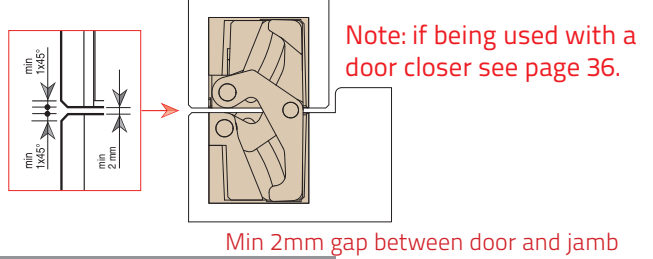

No. of Hinges based on Door Width & Weight

For doors over 2100mm tall, see page 36

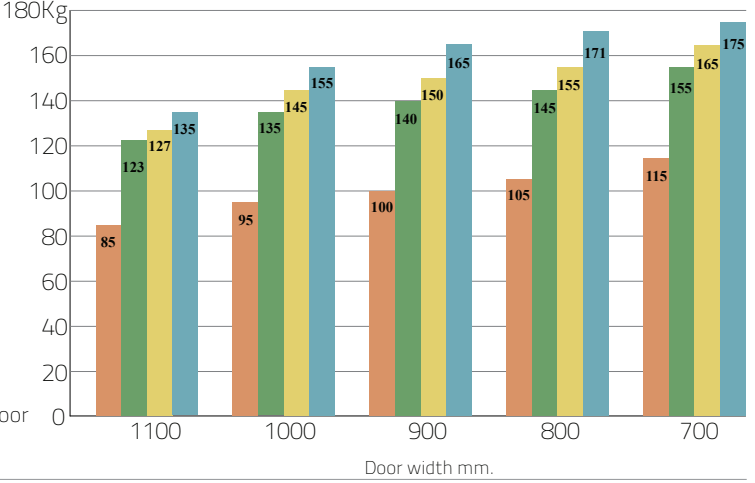
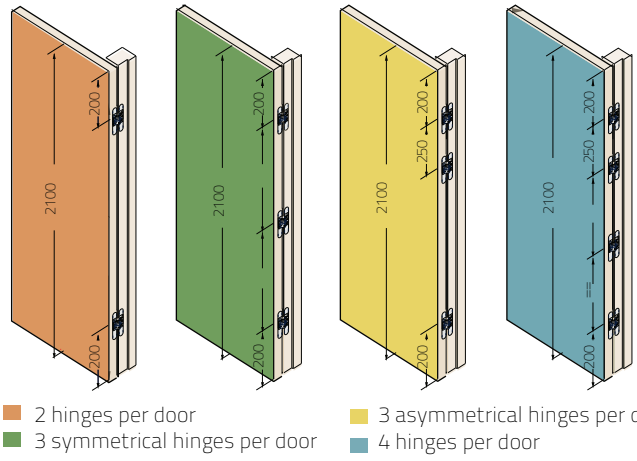

3D Concealed Hinge BAC1431 Functional Data

Fully Adjustable: Max 175kg

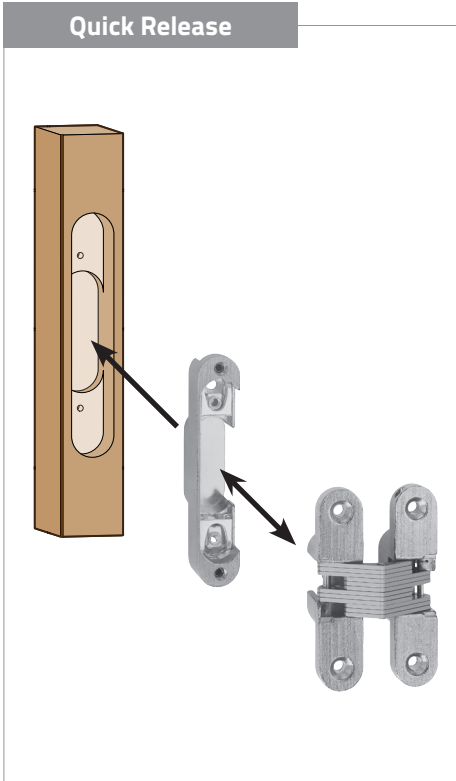
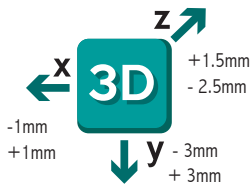

The BAC1431 3D adjustable concealed hinge is revolutionary in its design and is rated to carry a 175kg door to 180° opening aperture.

A blended door to wall look and feel: once closed, the BAC1431 hinge becomes invisible, hidden away by the jamb and the door butting up against each other.

Walls no longer need to be visually interrupted by the traditional butt hinge where the two leaves of the hinge meet and protrude out past the jamb.

The formal architectural composition of a wall can now continue without interruption, creating an aesthetically appealing appearance that is truly clean and elegant.

NEW 3D fully adjustable Concealed Hinge for heavy doors up to 175Kg. Solid Colour Including the knuckle.

Quick release: CEAM's quick release system is revolutionary - once the hinge is installed, you never need touch the door or jamb again.

The hinge sits within a cup, the cup is rebated and fixed to the door and jamb, the hinge is then fastened to the cup. As a result, if the door needs to come down, all you do is unscrew the locking bolts and remove the hinge from the cup.

The door can be removed and reinstalled for painting and adjustments without damaging timber or paint work, saving time and money.

Door movement: over time, this can be an expensive problem to fix. Not with the BAC1431 3D adjustable hinge; it specifically caters for door movement.

Once movement occurs, a door may not close properly or rub the paintwork. To fix, the door needs to come down and then the door and/or jamb needs to be planed and repainted; a costly and time consuming effort.

Using the BAC1431, simply adjust the position of the door via the settings within the hinge. This adjustment is done without the door coming down.



BAC1431 Quick Facts	
Min. door thickness	38mm
Max. door weight	175kg- Subject to Width & Weight Chart
Narrow timber rebate	29mm (ideal for thin jambs)
Gap when closed	2mm
Working aperture	180°
Manufacturing location	100% Made in Italy
Reliability	Certified to over 150,000 cycles
Adjustable	3D adjustment on 3 (X,Y,Z) axes
Quick Release	CEAM quick release system, never need to touch the door or jamb again



BAC1431 Order Codes	
BAC1431SI	Silver
BAC1431PB	Polished Brass
BAC1431BL	Black
BAC1431WH	White
BAC1431BZ	Bronze
BAC1431SN	Satin Nickel
BAC1431CR	Polished Chrome
BACJIG-BACT1431	Jig & hinge template (rent or buy) pg. 37-39

3D Concealed Hinge BAC1129 Technical Data

Fully Adjustable: Max 48kg

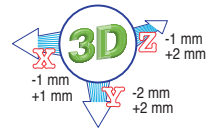

Timber Rebate Measurements

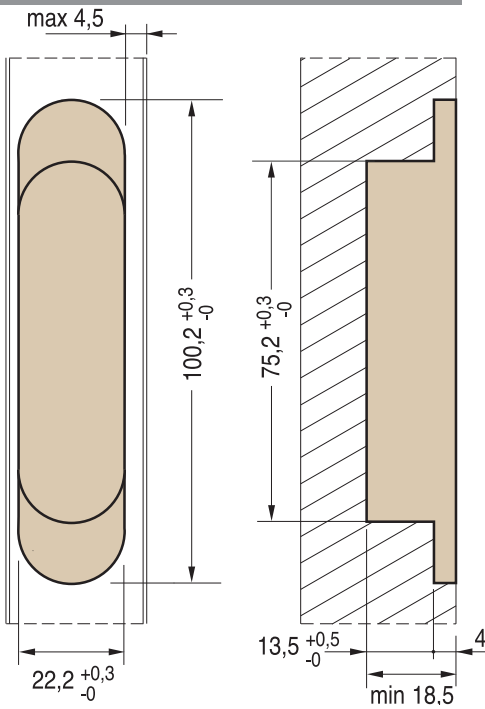

Only 18.5mm rebate
ideal for thin jambs

Hinge Measurements

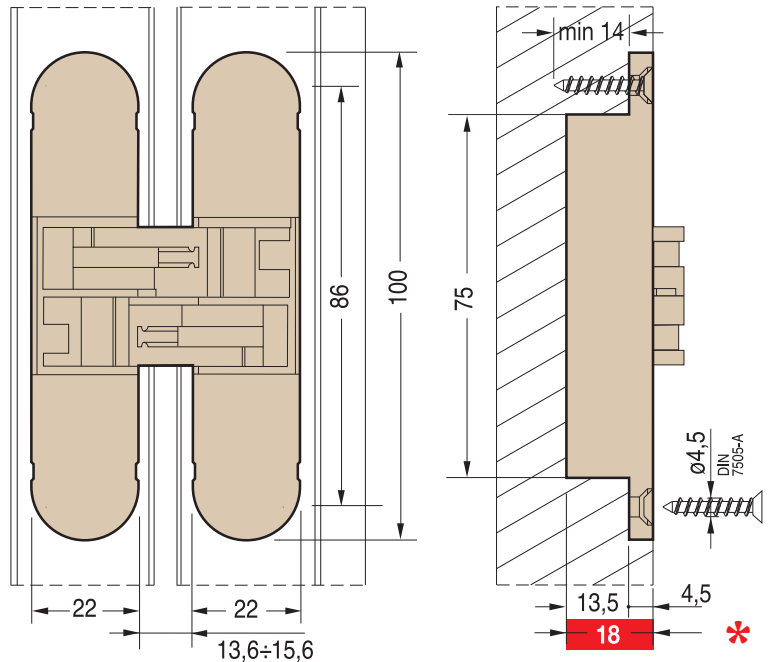

Only 18mm deep

BAC1129 Diagrams

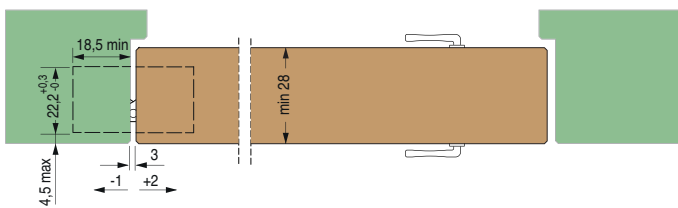

Hinge rebated 4.5mm max from edge of door and jamb on opening side

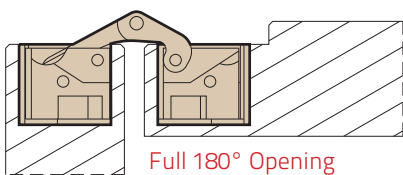

Full 180° Opening

BAC1129 Quick Facts

- 3D adjustable
- CEAM quick release system
- Available in multiple finishes
- 100% Made in Italy for over 50 years
- Suitable for high frequency opening doors
- Jig & router template available for easy installation
- Suitable for internal & external (under cover) locations
- Suitable for residential, commercial & industrial locations

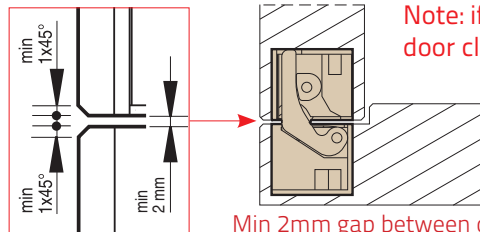

Note: if being used with a door closer see page 36.

Min 2mm gap between door and jamb

No. of Hinges based on Door Width & Weight

For doors over 2100mm tall, see page 36

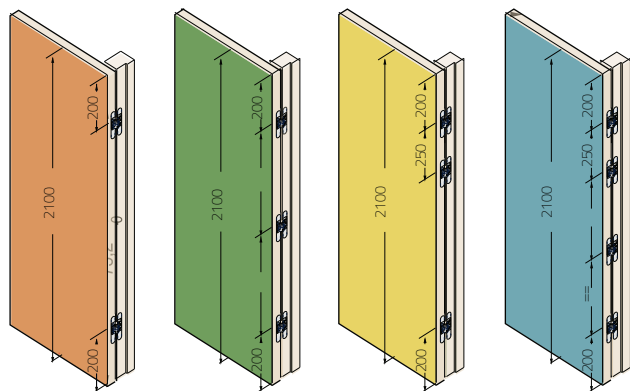

- 2 hinges per door
- 3 symmetrical hinges per door
- 3 asymmetrical hinges per door
- 4 hinges per door

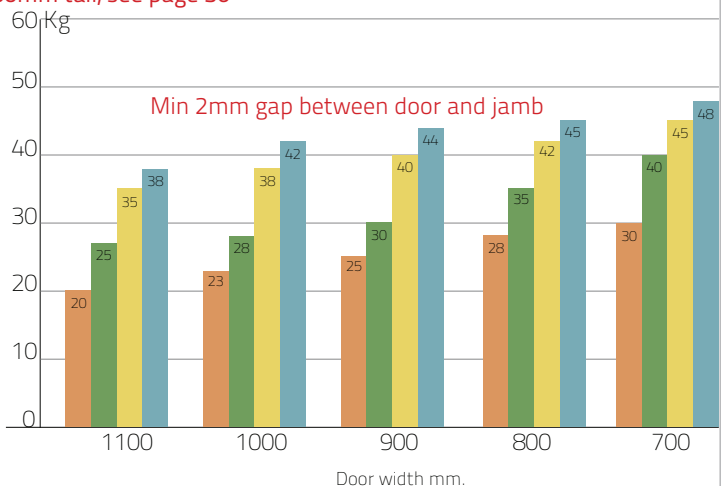

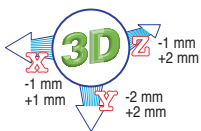

3D Concealed Hinge BAC1129 Functional Data

Fully Adjustable: Max 48kg

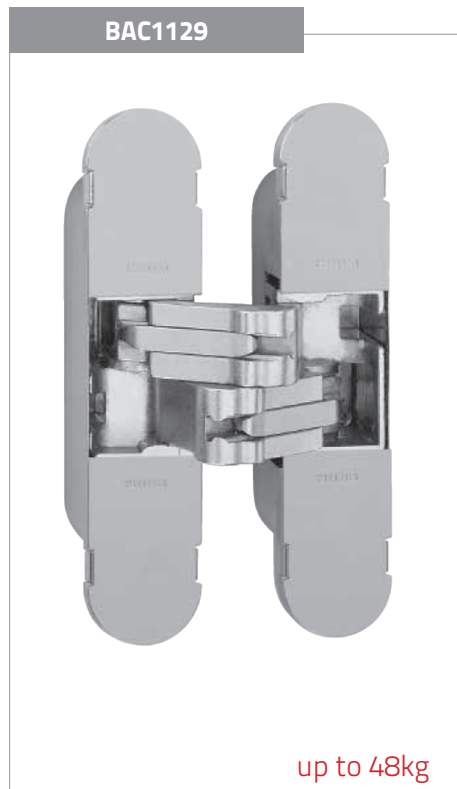
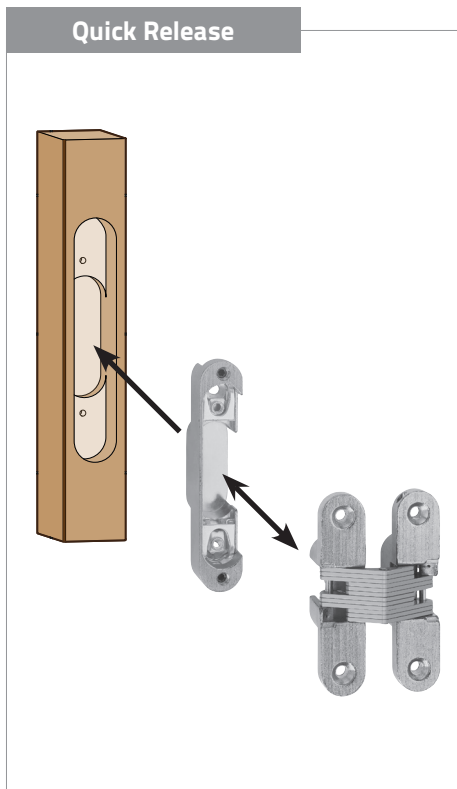

The BAC1129 3D adjustable concealed hinge is revolutionary in its design and is rated to carry a 48kg door to 180° opening aperture.

A blended door to wall look and feel: once closed, the BAC1129 hinge becomes invisible, hidden away by the jamb and the door butting up against each other.

Walls no longer need to be visually interrupted by the traditional butt hinge where the two leaves of the hinge meet and protrude out past the jamb.

The formal architectural composition of a wall can now continue without interruption, creating an aesthetically appealing appearance that is truly clean and elegant.

Quick release: CEAM's quick release system is revolutionary - once the hinge is installed, you never need touch the door or jamb again.

The hinge sits within a cup, the cup is rebated and fixed to the door and jamb, the hinge is then fastened to the cup. As a result, if the door needs to come down, all you do is unscrew the locking bolts and remove the hinge from the cup.

The door can be removed and reinstalled for painting and adjustments without damaging timber or paint work, saving time and money.

Door movement: over time, this can be an expensive problem to fix. Not with the BAC1129 3D adjustable hinge; it specifically

caters for door movement.

Once movement occurs, a door may not close properly or may rub the paintwork. To fix this, generally the door needs to come down and then the door and/or jamb needs to be planed and repainted; a costly and time consuming effort.

Using the BAC1129, simply adjust the position of the door via the settings within the hinge. This adjustment is done without the door coming down.

S.T.A.R.S.

BAC1129 Quick Facts

Min. door thickness	28mm
Max. door weight	48kg- Subject to Width & Weight Chart
Narrow timber rebate	18mm (ideal for thin jambs)
Gap when closed	2mm
Working aperture	180°
Manufacturing location	100% Made in Italy
Reliability	Certified to over 150,000 cycles
Adjustable	3D adjustment on 3 (X,Y,Z) axes
Quick Release	CEAM quick release system, never need to touch the door or jamb again

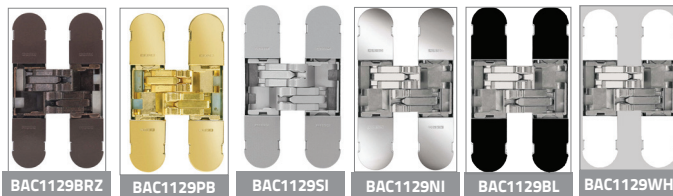

BAC1129 Order Codes	
BAC1129SI	Silver
BAC1129NI	Nickel
BAC1129PB	Brass
BAC1129WH	White (Cover Plates Only)
BAC1129BL	Black (Cover Plates Only)
BAC1129BRZ	Bronze
BACJIG-BAC1129	Jig & hinge template (rent or buy) pg. 37-39

3D Concealed Hinge BAC1030 Technical Data

Fully Adjustable Stainless Steel: Max 85kg

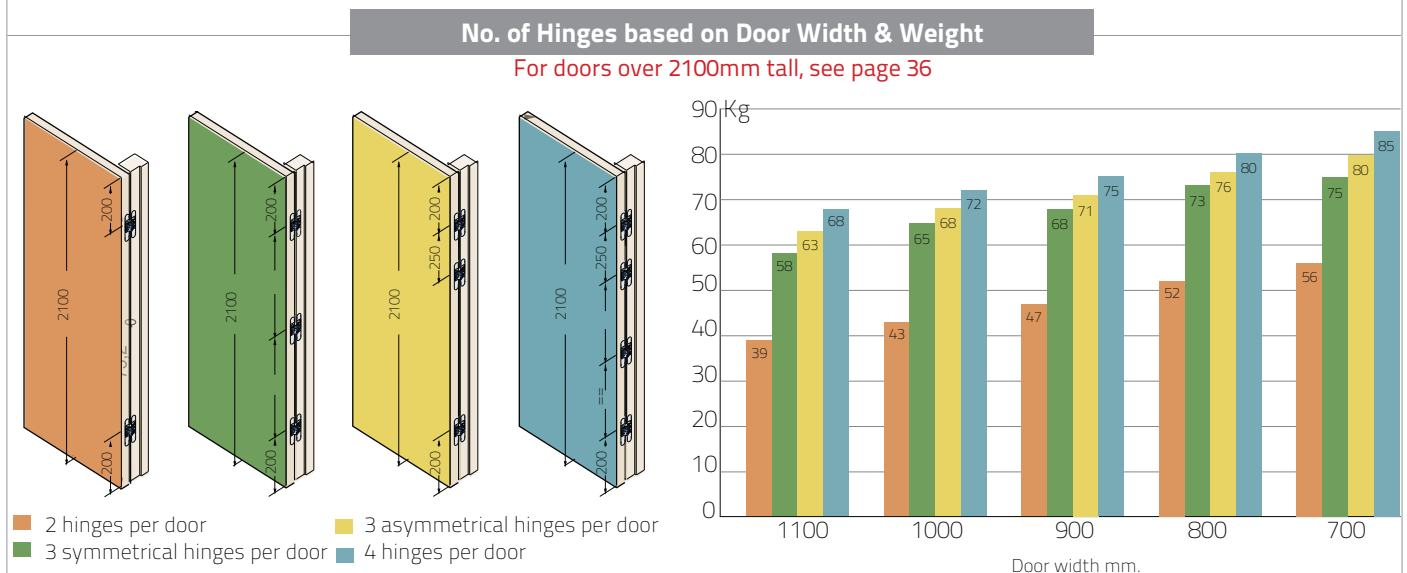
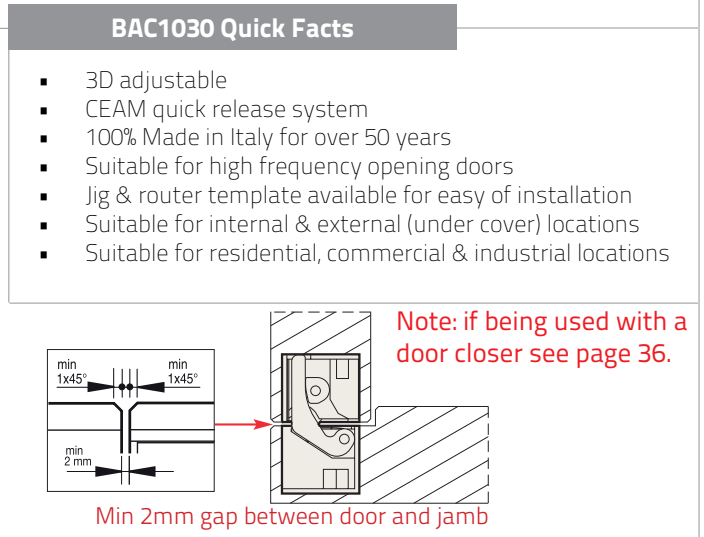
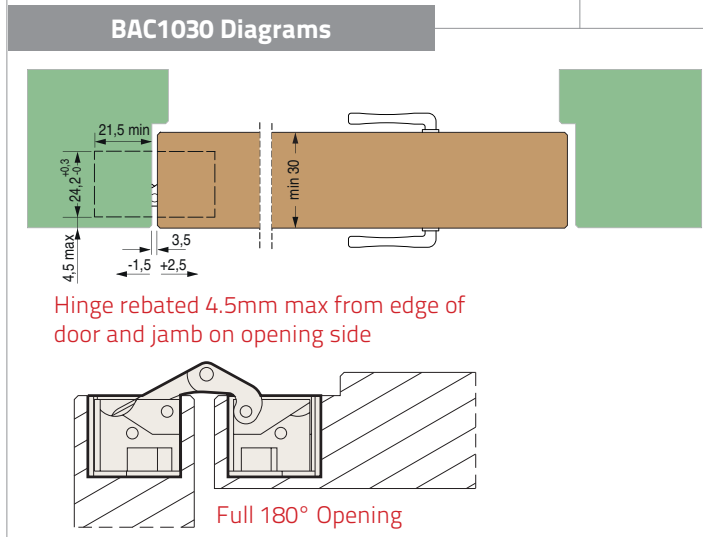
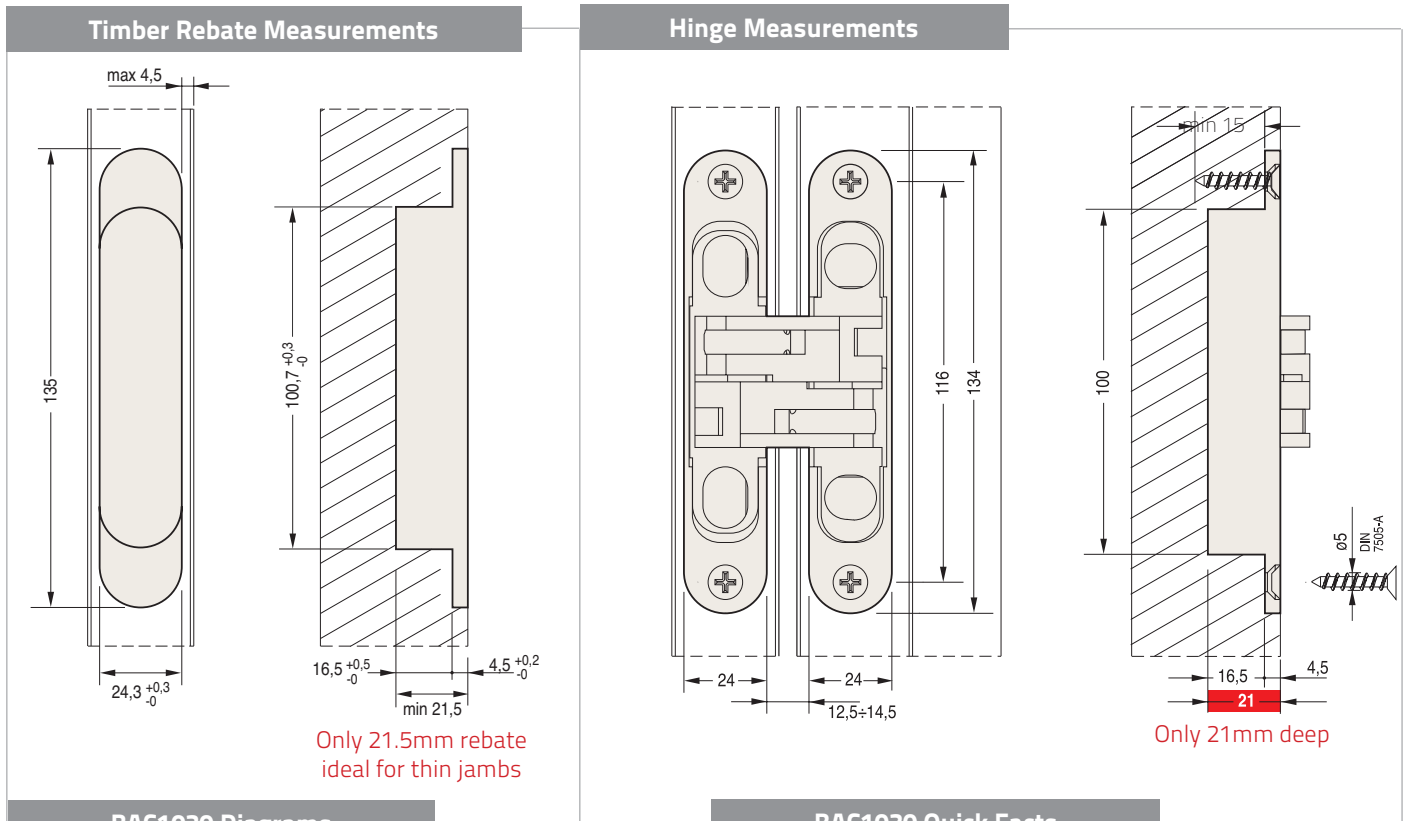
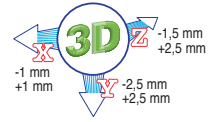

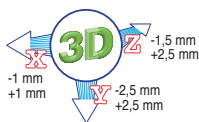

3D Concealed Hinge BAC1030 Functional Data

Fully Adjustable Stainless Steel: Max 85kg

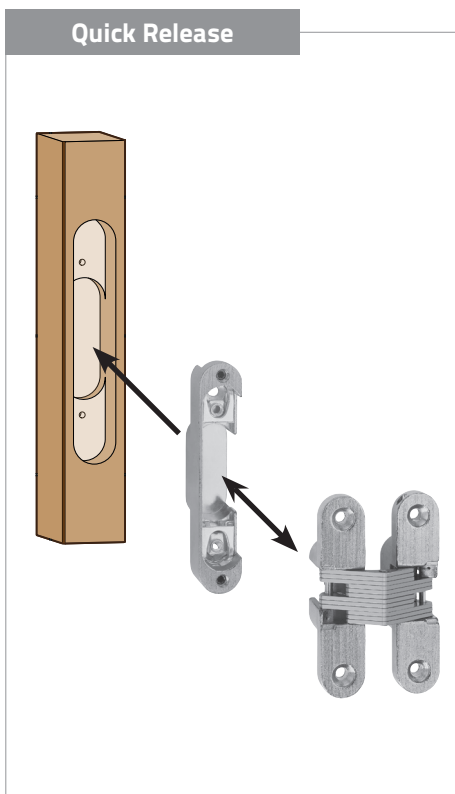
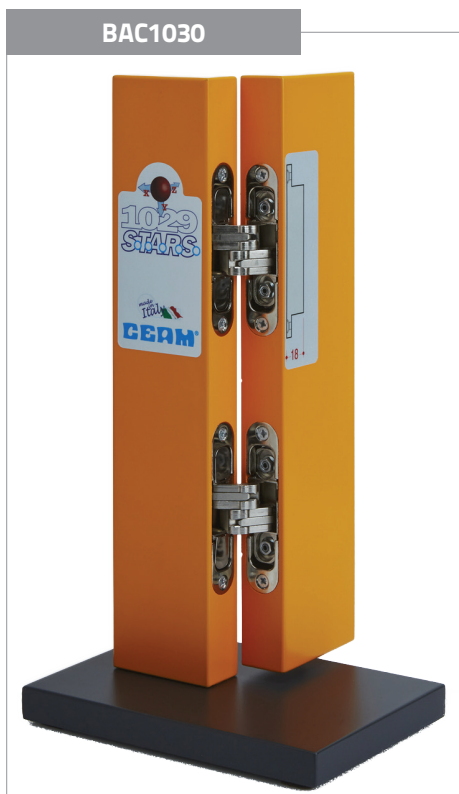

Made from Stainless Steel and ideally suited for internal and external environments, the BAC1030 3D adjustable concealed hinge is revolutionary in its design & is rated to carry upto 85kg door to 180° opening aperture.

A blended door to wall look and feel: once closed, the BAC1030 hinge becomes invisible, hidden away by the jamb and the door butting up against each other.

Walls no longer need to be visually interrupted by the traditional butt hinge where the two leaves of the hinge meet and protrude out past the jamb.

The formal architectural composition of a wall can now continue without interruption, creating an aesthetically appealing appearance that is truly clean and elegant.

Quick release: CEAM's quick release system is revolutionary - once the hinge is installed, you never need touch the door or jamb again.

The hinge sits within a cup, the cup is rebated and fixed to the door and jamb, the hinge is then fastened to the cup. As a result, if the door needs to come down, all you do is unscrew the locking bolts and remove the hinge from the cup.

The door can be removed and reinstalled for painting and adjustments without damaging timber or paint work, saving time and money.

Door movement: over time, this can be an expensive problem to fix. Not with the BAC1030 3D adjustable hinge; it specifically caters for door movement.

Once movement occurs, a door may not close properly or rub the paintwork. To fix, the door needs to come down and then the door and/or jamb needs to be planed and repainted; a costly and time consuming effort.

Using the BAC1030, simply adjust the position of the door via the settings within the hinge. This adjustment is done without the door coming down.

As an added benefit, being made of stainless steel, the BAC1030 hinge's base material brings peace of mind. You know it's going to last, whilst also giving you flexibility as to where you can use it: internally as well as externally.

BAC1030 Quick Facts

Min. door thickness	30mm
Max. door weight	85kg - Subject to Width & Weight Chart
Narrow timber rebate	21.5mm (ideal for thin jambs)
Gap when closed	2mm
Working aperture	180°
Manufacturing location	100% Made in Italy
Reliability	Certified to over 150,000 cycles
Adjustable	3D adjustment on 3 (X,Y,Z) axes
Quick Release	CEAM quick release system, never need to touch the door or jamb again



BAC1030 Order Codes

BAC1030SS	Stainless Steel (304 Grade)
BACJIG-BACT1030	Jig & hinge template (rent or buy) pg.37-39



304 Stainless Steel
Ideal for internal & external use

3D Concealed Hinge BAC1230S Technical Data

Fully Adjustable: Max 95kg

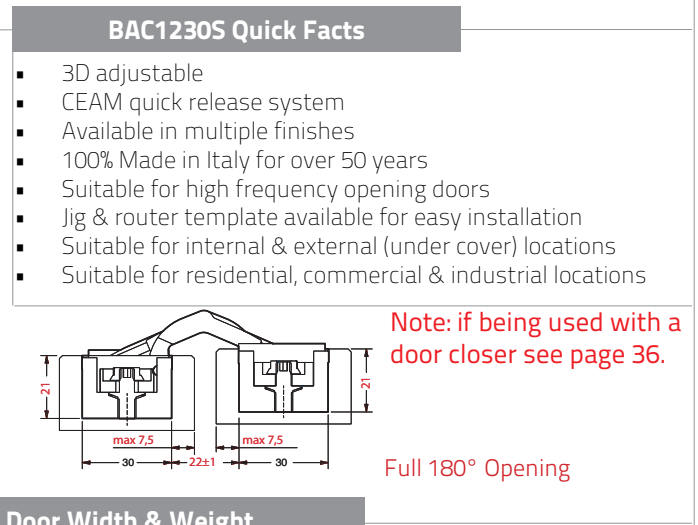
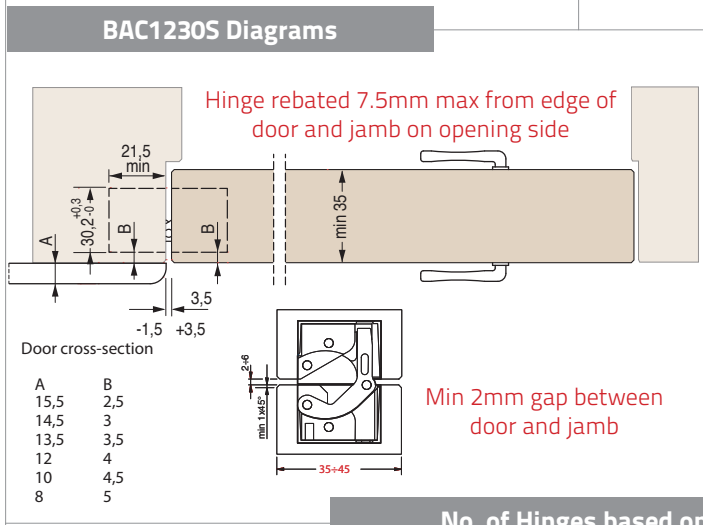
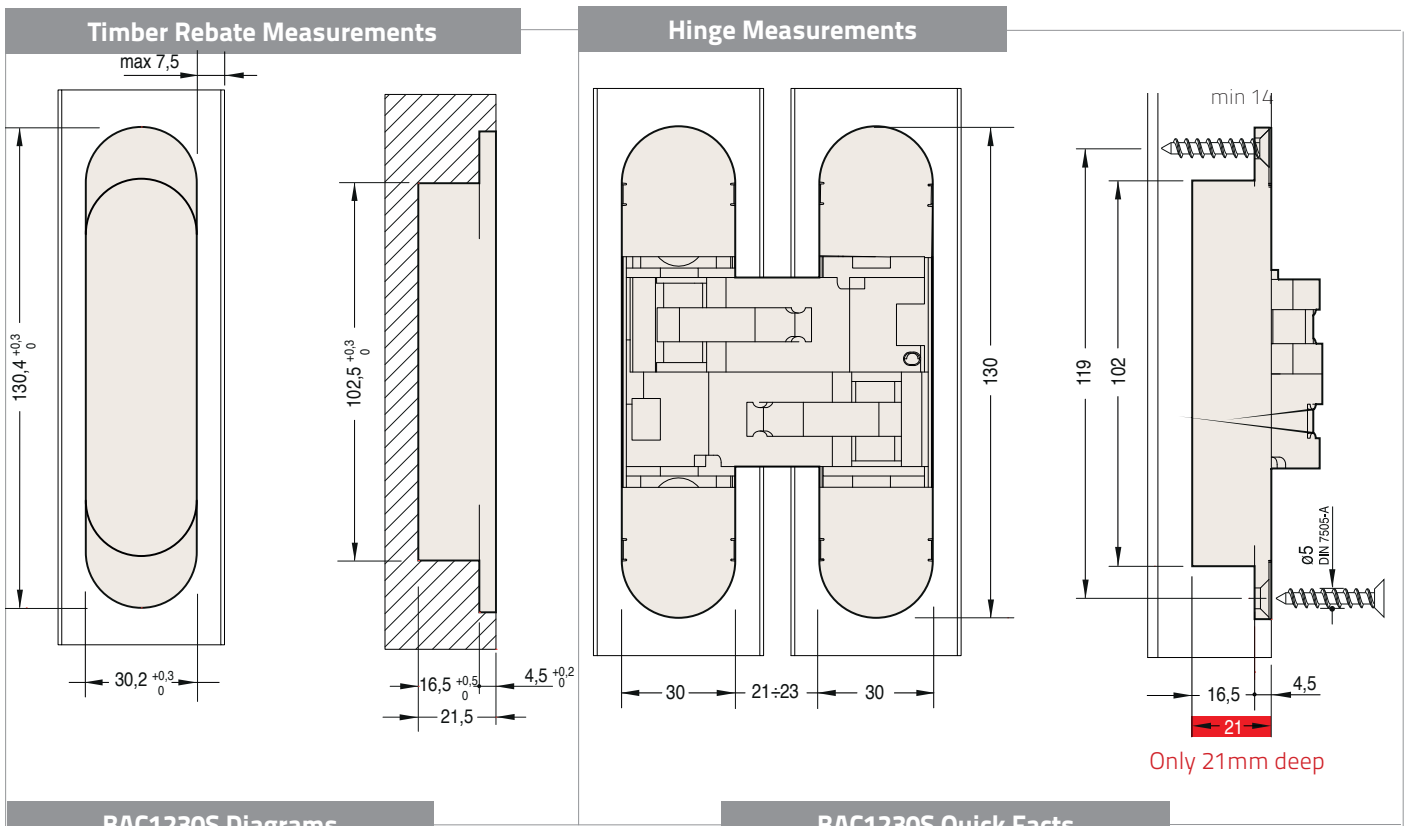
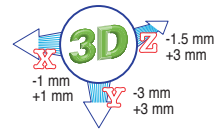

No. of Hinges based on Door Width & Weight

For doors over 2100mm tall, see page 36

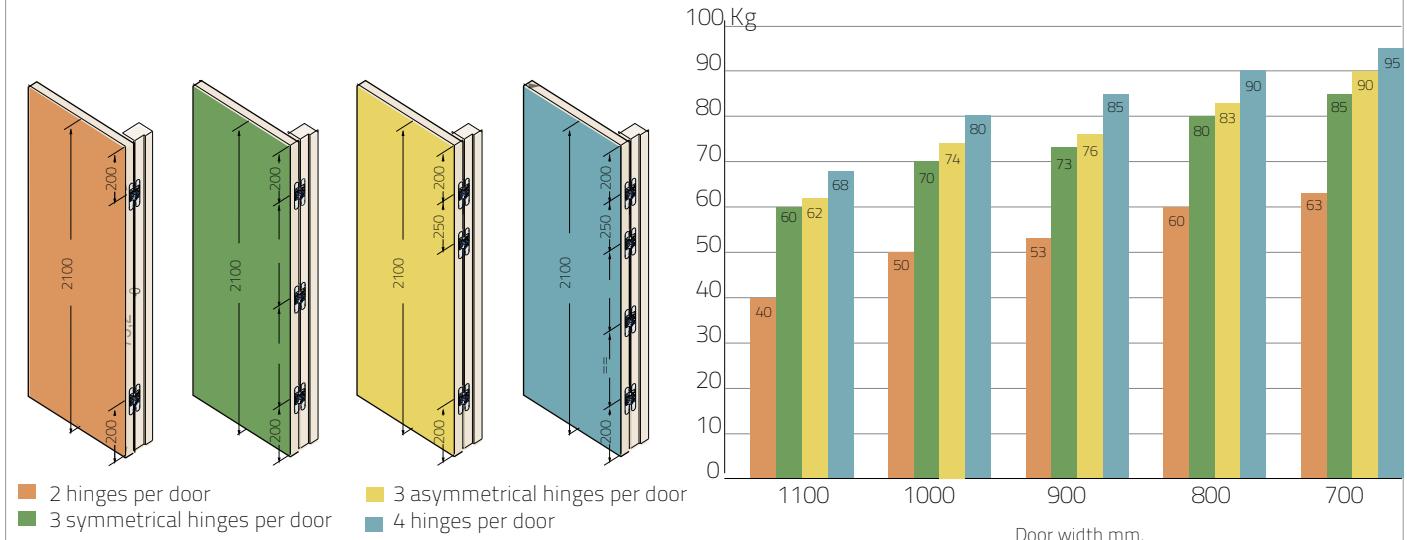

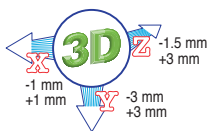

3D Concealed Hinge BAC1230S Functional Data

Fully Adjustable: Max 95kg

BAC1230



Quick Release

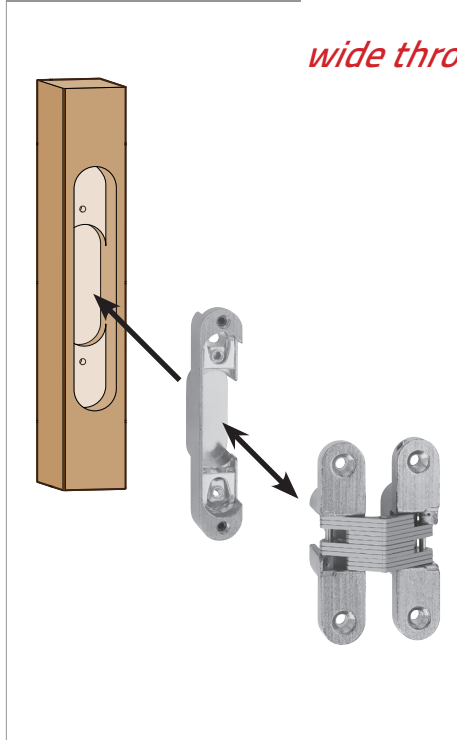

BAC1230

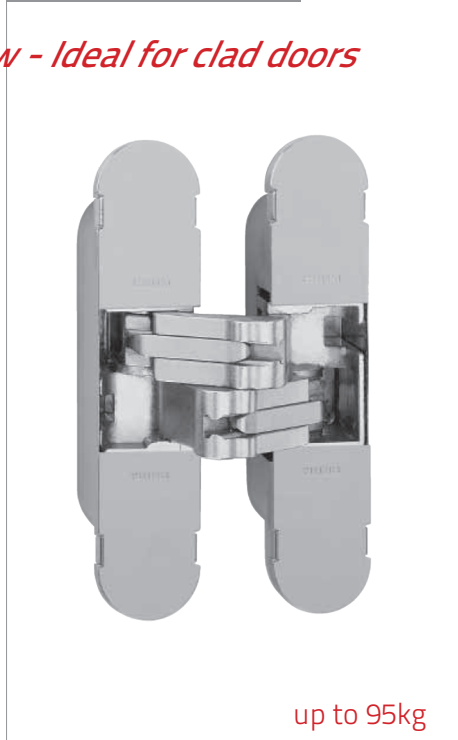

The BAC1230S 3D adjustable concealed hinge is revolutionary in its design and is rated to carry a 95kg door to 180° opening aperture.

A blended door to wall look and feel: once closed, the BAC1230S hinge becomes invisible, hidden away by the jamb and the door butting up against each other.

Walls no longer need to be visually interrupted by the traditional butt hinge where the two leaves of the hinge meet and protrude out past the jamb.

The formal architectural composition of a wall can now continue without interruption, creating an aesthetically appealing appearance that is truly clean and elegant.

Quick release: CEAM's quick release system is revolutionary - once the hinge is installed, you never need touch the door or jamb again.

The hinge sits within a cup, the cup is rebated and fixed to the door and jamb, the hinge is then fastened to the cup. As a result, if the door needs to come down, all you do is unscrew the locking bolts and remove the hinge from the cup.

The door can be removed and reinstalled for painting and adjustments without damaging timber or paint work, saving time and money.

Door movement: over time, this can be an expensive problem to fix. Not with

the BAC1230S 3D adjustable hinge; it specifically caters for door movement.

Once movement occurs, a door may not close properly or rub the paintwork. To fix, the door needs to come down and then the door and/or jamb needs to be planed and repainted; a costly and time consuming effort.

Using the BAC1230S, simply adjust the position of the door via the settings within the hinge. This adjustment is done without the door coming down.

S.T.A.R.S.

BAC1230S Quick Facts

Min. door thickness	35mm
Max. door weight	95kg - Subject to Width & Weight Chart
Narrow timber rebate	21mm (ideal for thin jambs)
Gap when closed	2mm
Working aperture	180°
Manufacturing location	100% Made in Italy
Reliability	Certified to over 150,000 cycles
Adjustable	3D adjustment on 3 (X,Y,Z) axes
Quick Release	CEAM quick release system, never need to touch the door or jamb again

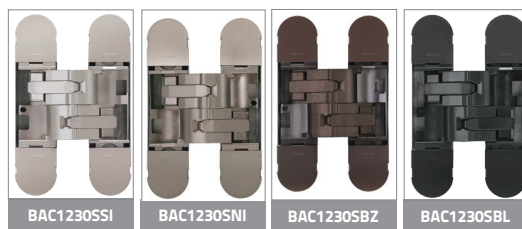

BAC1230S Order Codes	
BAC1230SSI	Silver
BAC1230SNI	Polished Nickel
BAC1230SBZ	Bronze
BAC1230SBL	Black
BACJIG-BACT1230S	Jig & hinge template (rent or buy) pg. 37-39

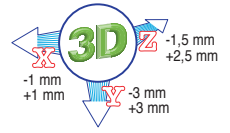

3D Concealed Hinge BAC1131S Technical Data

Fully Adjustable: Max 160kg

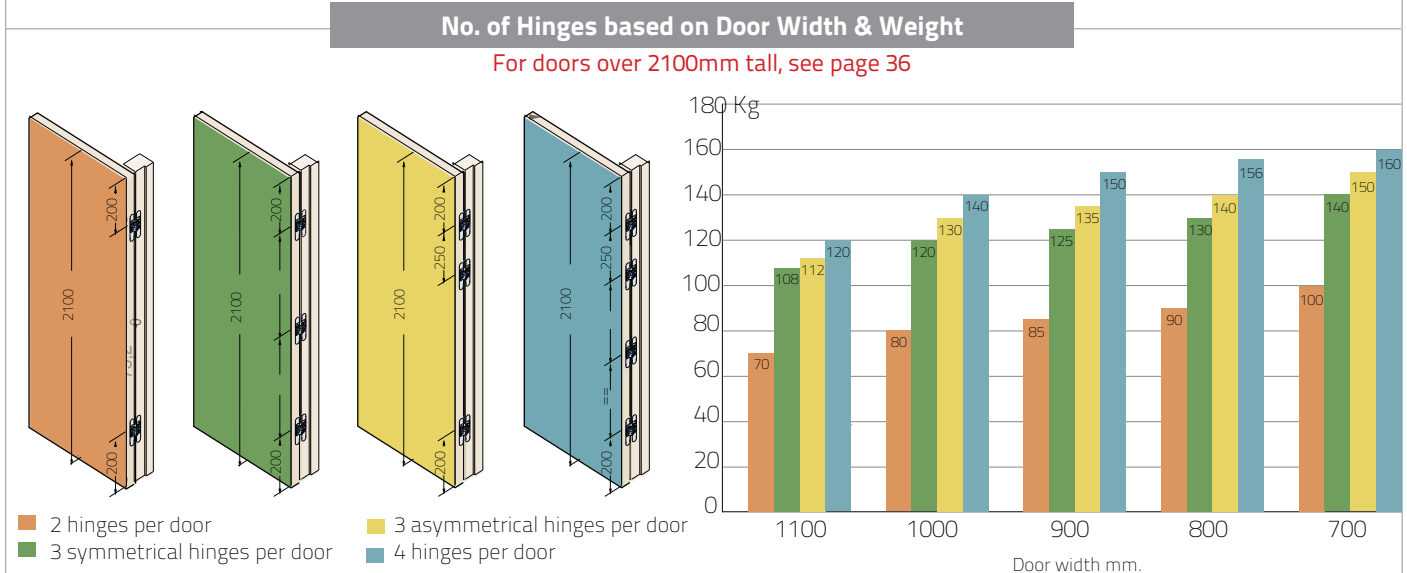
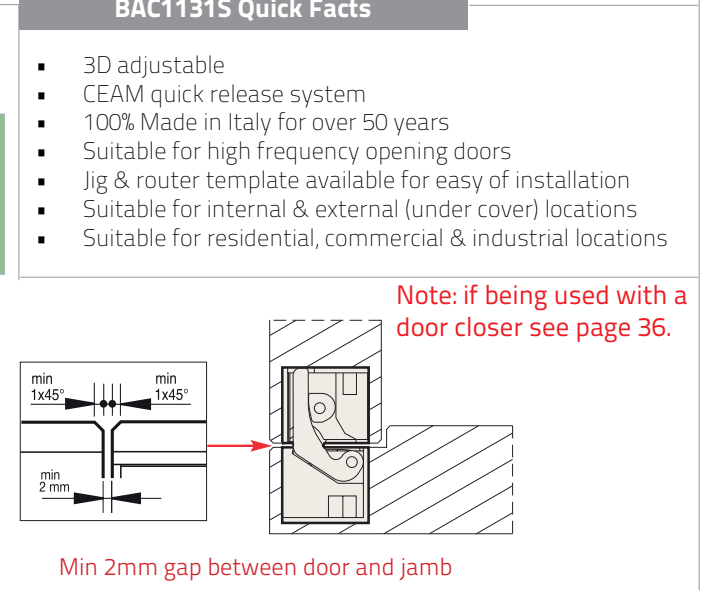
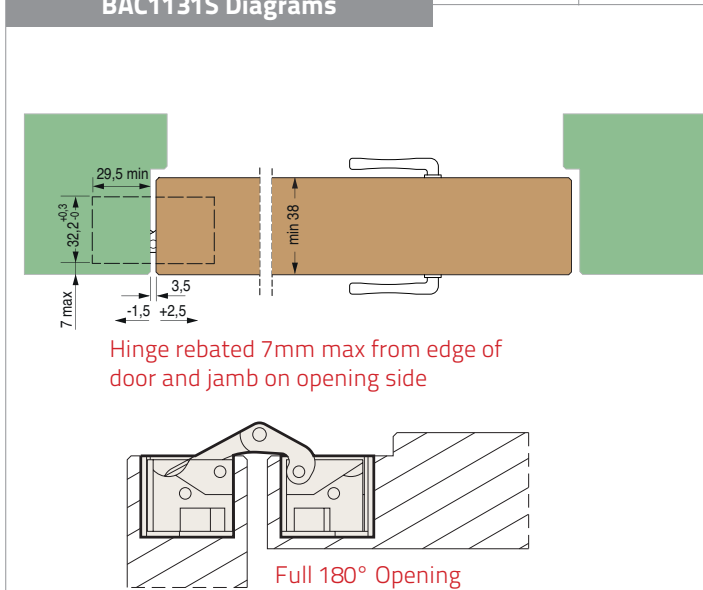
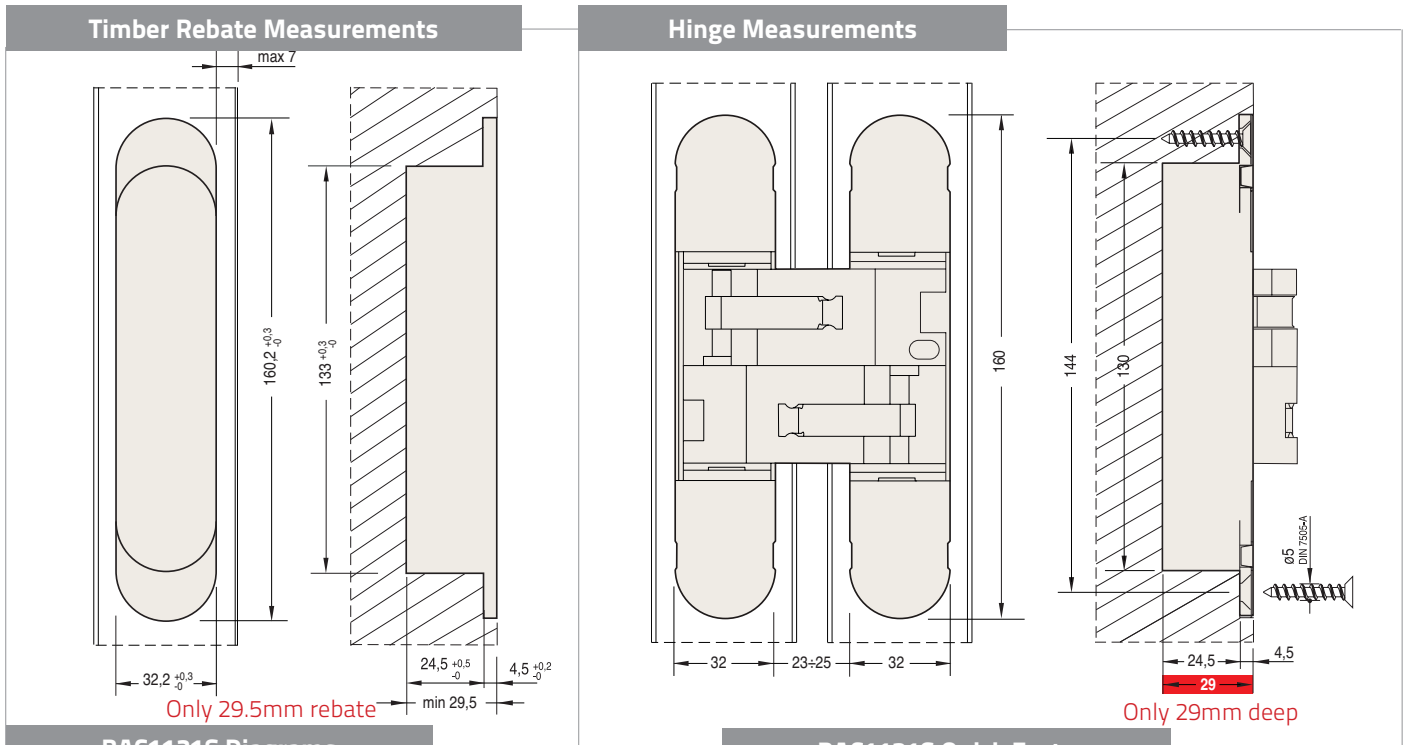

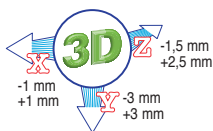

3D Concealed Hinge BAC1131S Functional Data

Fully Adjustable: Max 160kg

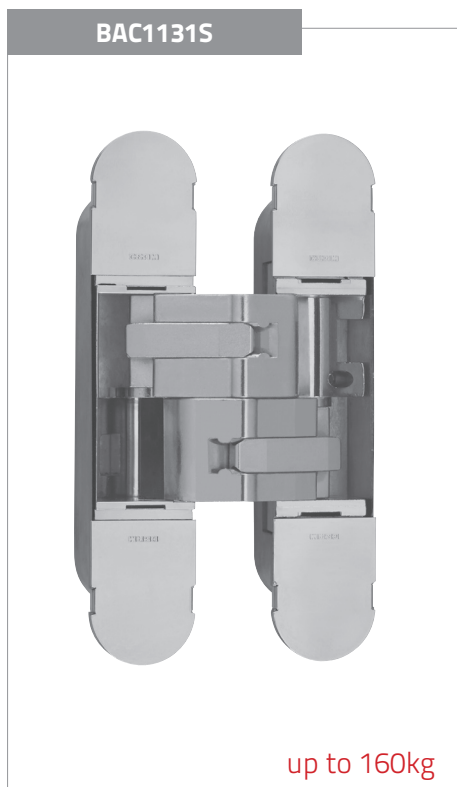
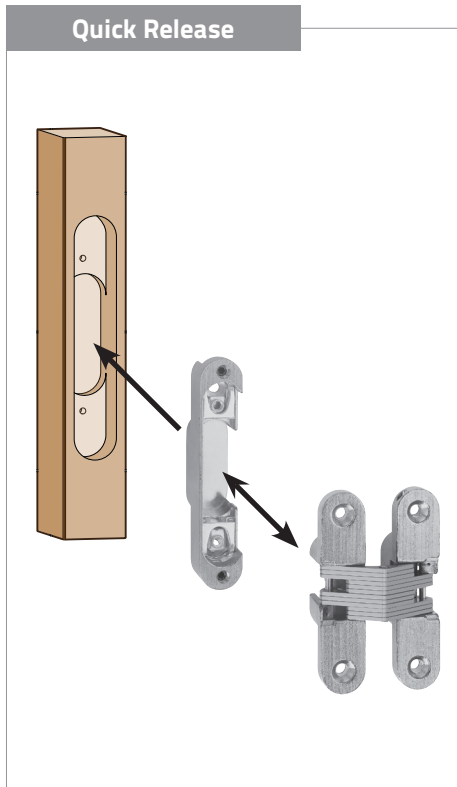

up to 160kg

The BAC1131S 3D adjustable concealed hinge is revolutionary in its design and is rated to carry a 160kg door to 180° opening aperture.

A blended door to wall look and feel: once closed, the BAC1131S hinge becomes invisible, hidden away by the jamb and the door butting up against each other.

Walls no longer need to be visually interrupted by the traditional butt hinge where the two leaves of the hinge meet and protrude out past the jamb.

The formal architectural composition of a wall can now continue without interruption, creating an aesthetically appealing appearance that is truly clean and elegant.

Quick release: CEAM's quick release system is revolutionary - once the hinge is installed, you never need touch the door or jamb again.

The hinge sits within a cup, the cup is rebated and fixed to the door and jamb, the hinge is then fastened to the cup. As a result, if the door needs to come down, all you do is unscrew the locking bolts and remove the hinge from the cup.

The door can be removed and reinstalled for painting and adjustments without damaging timber or paint work, saving time and money.

Door movement: over time, this can be an expensive problem to fix. Not with the BAC1131S 3D adjustable hinge; it specifically caters for door movement.

Once movement occurs, a door may not close properly or rub the paintwork. To fix, the door needs to come down and then the door and/or jamb needs to be planed and repainted; a costly and time consuming effort.

Using the BAC1131S, simply adjust the position of the door via the settings within the hinge. This adjustment is done without the door coming down.

S.T.A.R.S.

BAC1131S Quick Facts

Min. door thickness	38mm
Max. door weight	160kg - Subject to Width & Weight Chart
Narrow timber rebate	29.5mm
Gap when closed	2mm
Working aperture	180°
Manufacturing location	100% Made in Italy
Reliability	Certified to over 150,000 cycles
Adjustable	3D adjustment on 3 (X,Y,Z) axes
Quick Release	CEAM quick release system, never need to touch the door or jamb again



BAC1131S Order Codes

BAC1131SSI	Silver
BAC1131SNI	Polished Nickel
BAC1131SPB	Polished Brass
BAC1131SBZ	Bronze
BAC1131SBL	Black
BACJIG-BACT1131S	Jig & hinge template (rent or buy) pg.37-39

Technical information

The following issues should be considered during the hinge selection process in order to prevent damage and or hinge failure: All CEAM hinges come with a 2 year manufacturer's guarantee subject to following points:

- Place of use and frequency of opening
- Weight of the door leaf
- Door closer internal or external side
- Automatic or semi-automatic opening systems
- Door dimensions
- Placement and installation of the hinges
- Coating or baseboard
- Direction of use & installation

In public buildings, due to the high opening & closing frequencies of the doors, it is recommended to always calculate the door to be heavier than it actually is. Better to over spec the door than under spec it, even if the weight and size of the door does not require a third or fourth hinge. CEAM hinges conform to the strictest European standards and regulations; they have passed all the necessary stress, corrosion resistance, fire resistance, flow and durability tests in Europe. CEAM tests its hinges on doors that are 2100 x 850 mm and 2100 x 1000mm in size. For an ideal performance, it is advisable to lubricate the hinge once every two years, or more, depending on the frequency of opening.

NUMBER OF HINGES PER DOOR

For doors between 2100mm - 2399mm high and up to 1100mm wide:

1. Start with the yellow column based on 3 hinges relating to your door width. Reduce this max weight by 25%.
 - a. If your door weighs less than this reduced weight, you can stay with 3 hinges installed as per the yellow image.
 - b. If your door weighs more than this reduced weight, move to the blue 4 hinge column.
2. Start with the blue column based on 4 hinges relating to your door width. Reduce this max weight by 25%.
 - a. If your door weighs less than this reduced weight, you can use 4 hinges on this door installed as per the blue image.
 - b. If your door weighs more than this reduced weight, please move to a larger capacity hinge. If one is not available, please contact Bellevue Architectural for advice.

For doors between 2400mm and 2699mm high and up to 1100mm wide:

1. Start with the blue column. This will now have standard 5 hinges per door required based on your door width. Reduce the max weight of the blue column by 25%.
 - a. If your door weighs less than this reduced weight, you can stay with 5 hinges installed as per the 5-hinge installation image (3 at the top, 1 in the middle and 1 at the bottom).
 - b. If your door weighs more than this reduced weight, please move to a larger capacity hinge. If one is not available, please contact Bellevue Architectural for advice.

For doors over 2700mm and wider than 1100mm:

We do not recommend the use of CEAM concealed hinges. Please contact Bellevue Architectural for advice

USE OF A DOOR CLOSER

When using a door closer (SLIDE ARM CAM ACTION ONLY), CEAM suggest mounting an additional hinge in the upper part of the door, as these mechanisms modify the opening forces on the door. A door closer will increase the load on the door effectively making the door heavier than it actually is. As a result it may alter / compromise the capacity and integrity of the hinges selected. Please select the correct hinge model with this in mind.

- For door closers without an opening force, CEAM suggest considering the door to be 25% heavier than it actually is.
- For door closers with an opening force the effect it is much greater; it is estimated that the door leaf effective mass is 75% heavier than it actually is. Please consult our technical department for more information.

HINGE SELECTION

The information contained within this document is intended as a guide only. In practice, the variables that affect the correct function of an invisible hinge are several: facts that need to be taken into consideration include the nature of the door, opening and closing frequency, weight and door size etc. It is reasonable to expect that analysis of relevant key points is taken into consideration during the hinge selection process. The customer must be sure the hinge selected is suitable for the door and environment in question and are appropriate to satisfy even external factors beyond what is indicated by the hinges specification. If necessary, please contact our technical department for more information.

TAILOR MADE

For special applications, if none of the published hinges in this catalogue are suitable, please provide us more information about your technical and design needs. The CEAM invisible hinge range is extensive and we may have a better suited model for your requirements.

ADJUSTMENT IN 3 DIMENSIONS

Every adjustment requires adequate attention. The adjustment range indicated must be absolutely respected. Excessive force during adjustments may lead to a possible malfunction in the hinge that could cause the hinge to fail.

ZERO POSITION

All CEAM hinges are delivered with all the adjustments centered.

After installation and after each adjustment all components must be tightened firmly.

ADJUSTMENT ON THE THREE INDEPENDENT AXES

Horizontal from -1.5 mm to +3.5 mm (see individual specifications)

Vertical from -3.0 mm to +3.0 mm (see individual specifications)

Depth +/- 1.0 mm

HORIZONTAL ADJUSTMENT

Slightly loosen the locking nuts. With the aid of the allen key, move the internal cage to find the preferred position. Tighten all lock nuts.

VERTICAL ADJUSTMENT

Slightly loosen the locking nuts. By acting on the door leaf, raise it to the required level. Tighten all lock nuts.

DEPTH ADJUSTMENT

Slightly loosen the locking nuts. Act with hexagonal allen key to make the adjustment. Tighten all lock nuts.

All adjustments are carried out with 8mm hex wrench and allen key 2.5 mm (for art.1131s to be made with a hexagonal 10mm & 3mm allen key).

Installation, Jig, Templates & Routers

Jig Type 1: Jig, Templates & Router - Purchase.

Complete installation kit - Suitable for fully upright assembled doors and jambs

Main Features:

Easy on-site installation using CEAM's new complete router kit; suitable for the full range of CEAM concealed hinges. Installation is a one step operation. Faster, easier, smarter. No need to change templates. No need to measure or mark the door or jamb.

- Designed for on-site installation.
- Double Insulation.
- Input Power 1000W
- No-load speed: 14000-27000/ mm
- Chuck collet: 8mm
- Max. Bit diameter 32mm
- Max. Drilling dimension: 165 x 74mm
- Max. Drilling depth: 40mm
- Clamp opening: 33 - 200mm
- Weight: 4.3Kg

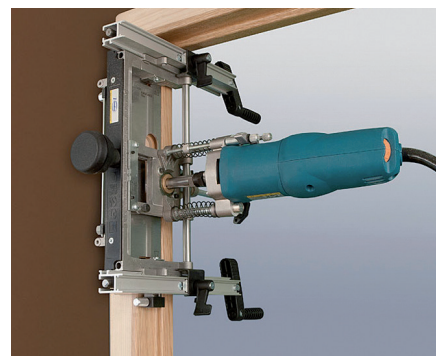
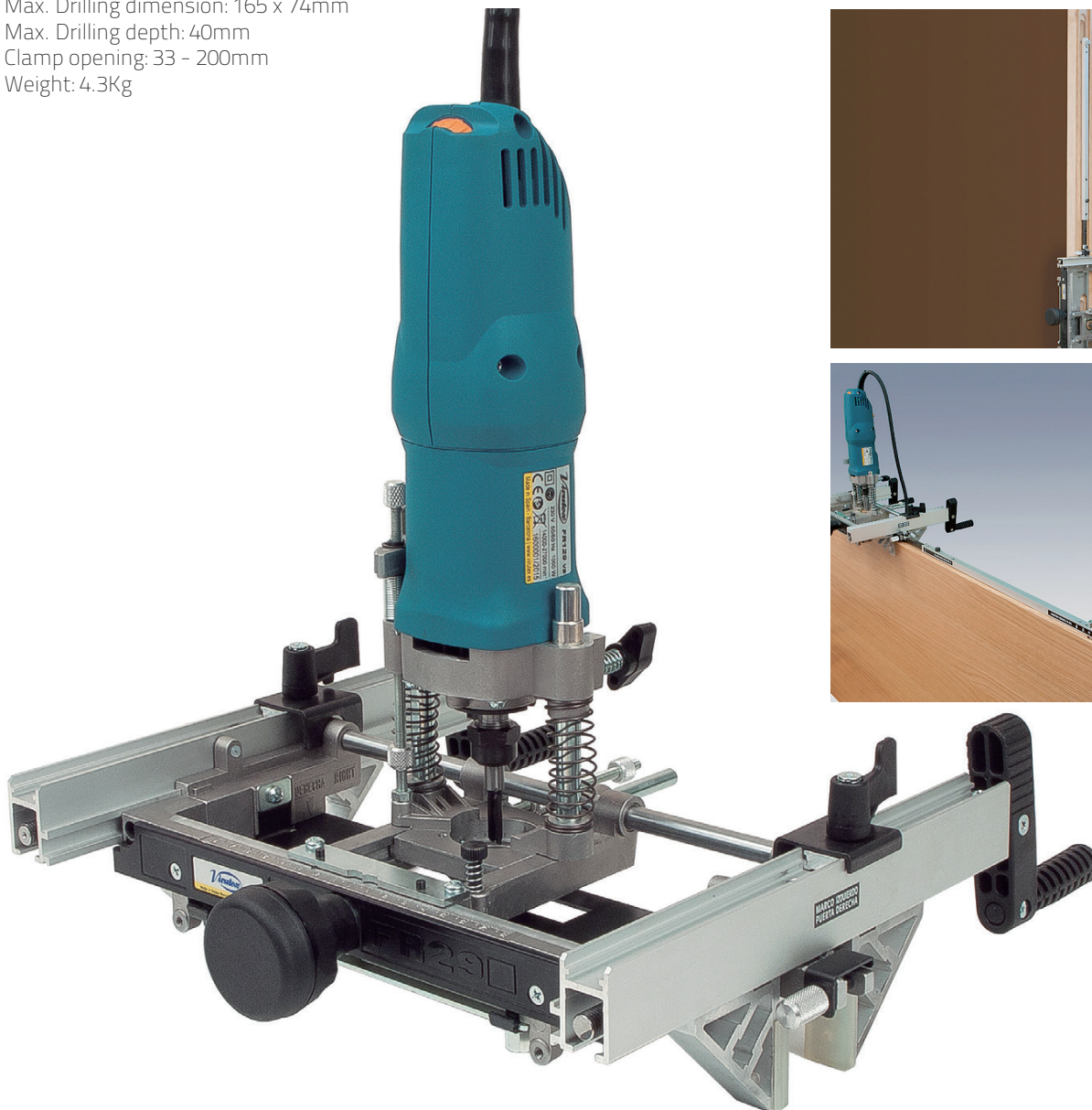

JIG Type 1.

BACJIG1B	Purchase complete kit including all hinge templates
Kit Contents	Router, guide, jig and all hinge templates

A complete video of the installation process using both jig types is available for viewing on the Bellevue Architectural website - www.bellevuearch.com.au/videos

Installation, Jig, Templates & Routers

Jig Type 2: Jig & Template Only - Rent or Purchase.

Use your own router and template guide - Suitable for unassembled doors and jambs

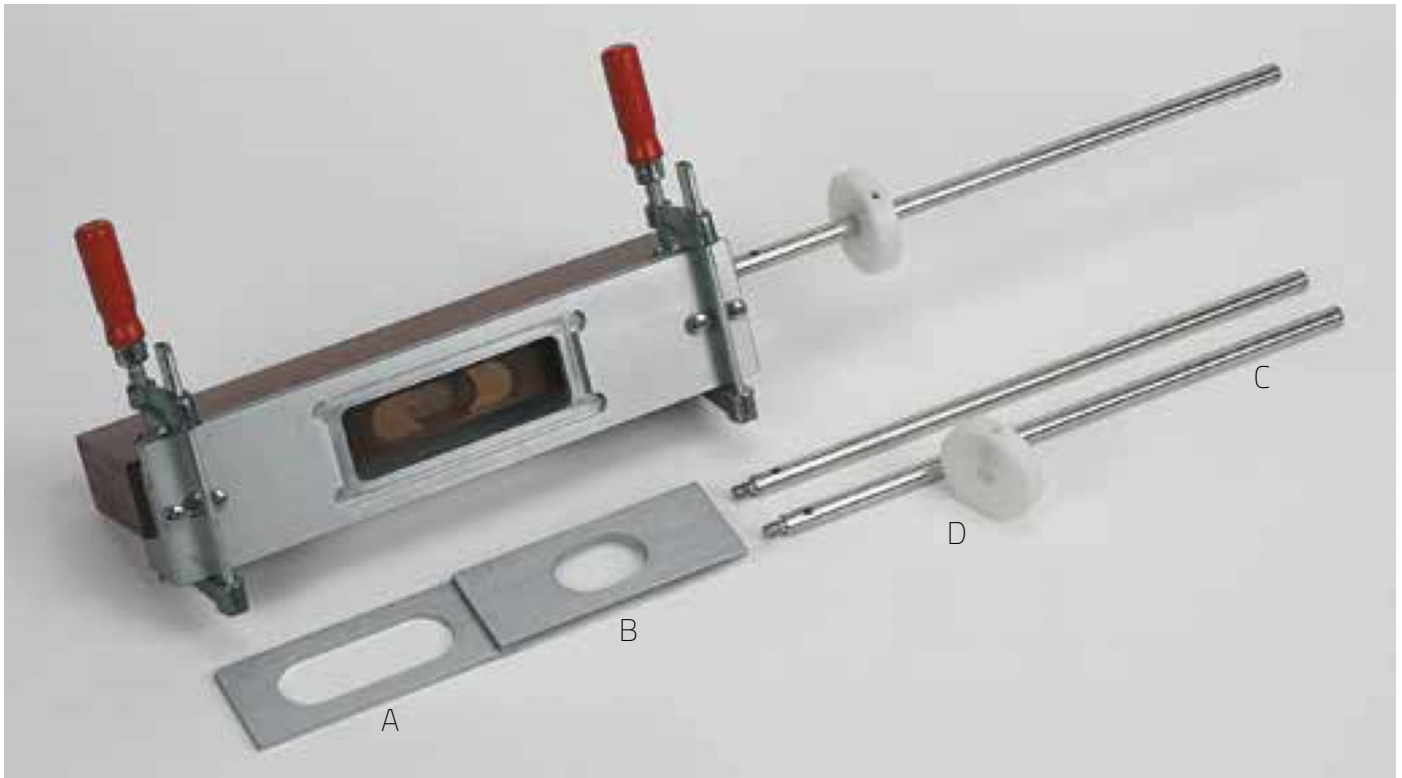

The routing templates (A & B), which comprise of a frame and two inserts, enables the drilling/ routing of two slots for the invisible hinges body, the templates are made from 5 mm thick aluminium plates.

The strength of the materials guarantee precise execution of the slots with a manual pantograph (16 mm diam. cutter and 27 mm external guide ring provided for all manual pantographs).

For each hinge model, two types of insertions (easily replaceable) are used: one (A) to route the hinge wing slots and the other (B) to cater for the internal depth of the hinge.

The equipment is completed with:

Extension arms (C) with a nylon ring (D), they allow to establish the desired distance between slots on the door - both left and right - and on the frame.

Blocking Clamps

- * These are very important, as they must match the hinge model being used. The reference for both the templates are stamped on each. If the incorrect template is used, the hinge will not fit into the hole which has been routed into the door and jamb.

JIG Type 2.	
BACJIGB	Purchase Jig Only (all models except BAC1131S)
BACJIGB1131SB	Purchase Jig Only (only for BAC1131S)
BACJIGR	Rent P/W Jig Only (all models except BAC1131S)
BACJIGR1131SR	Rent P/W Jig Only (only for BAC1131S)
BACTXXXXB	Purchase Template to suit model of hinge
BACTXXXXR	Rent P/W Template to suit model of hinge
Kit Contents	Jig only

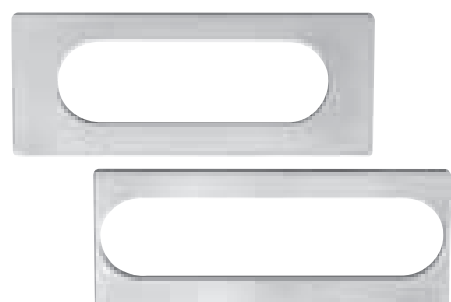

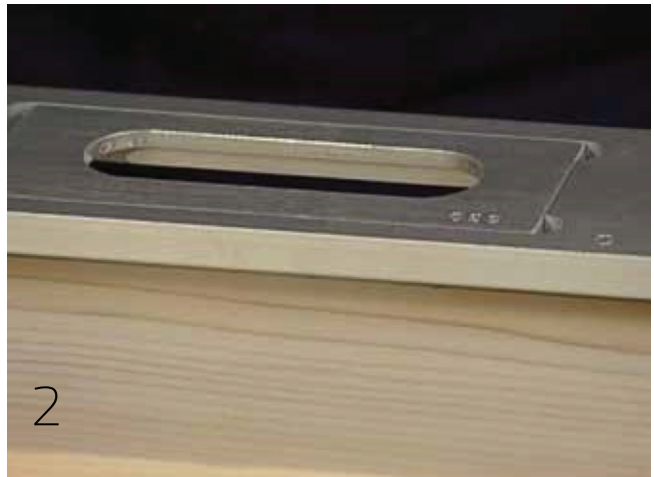

Fixing box for metal jambs & doors

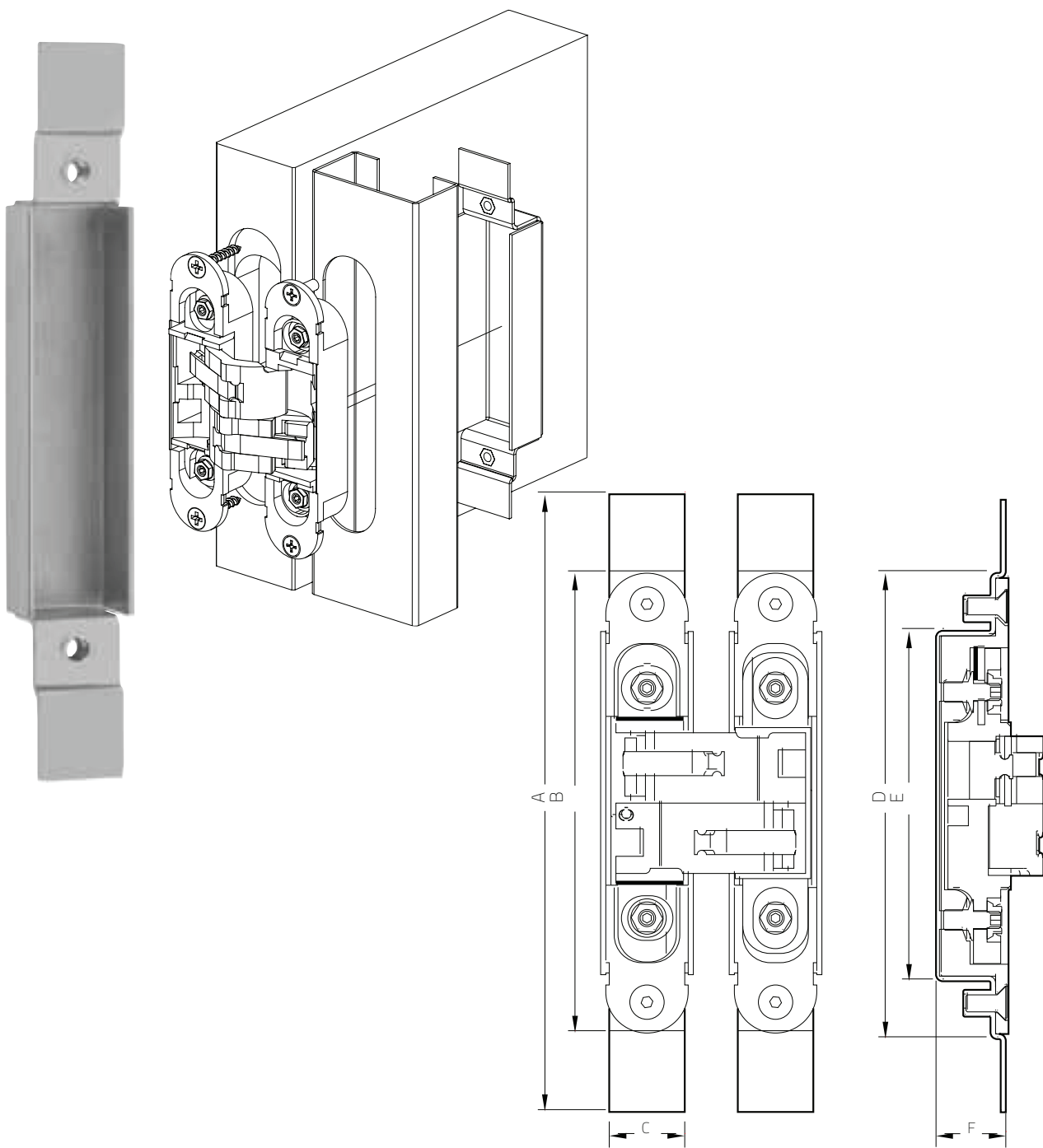

Fixing Box Dimensions						
Code.	A	B	C	D	E	F
BAC1230XGP	180mm	130mm	29mm	133mm	105mm	21mm
BAC1131XGP	198mm	161mm	30mm	164mm	133mm	31mm

The BACXGP metal fixing box is used to fit a concealed hinge to a metal hollow section of a post, jamb or door.

Offset fixing plate

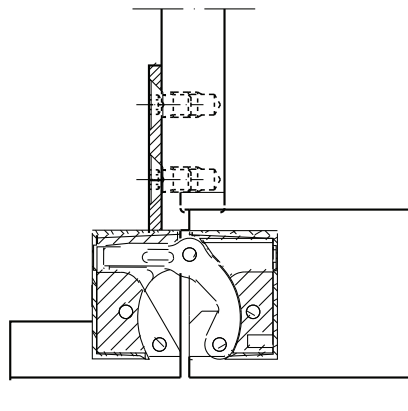
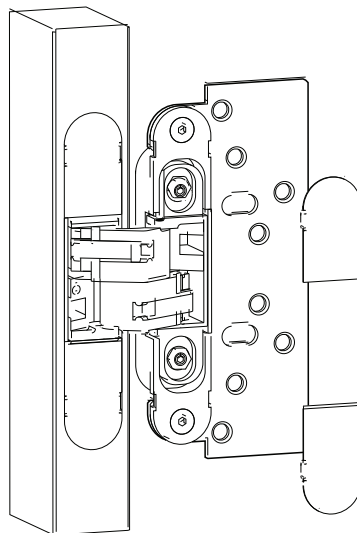
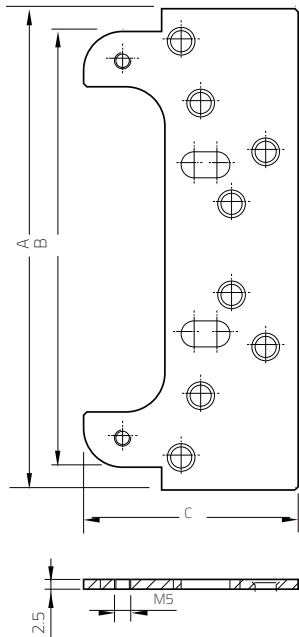
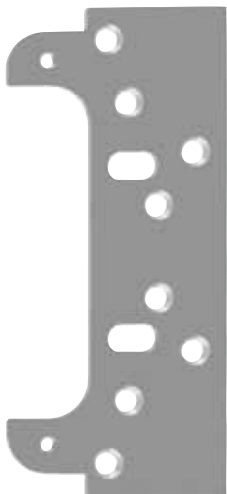

Offset Fixing Plate Dimensions				
Code.	A	B	C	D
BAC1230SXFP	136mm	136mm	70mm	3mm
BAC1131SXFP	180mm	166mm	74mm	3mm

The BAC1XFP offset fixing plate, when used in conjunction with the concealed hinge, allows a door to be hung offset to a wall or timber / metal post or door jamb where required.

Adjustment wedge

BACWEG Adjustment Wedge
 An aid to assist in positioning the door when hanging using CEAM concealed hinges

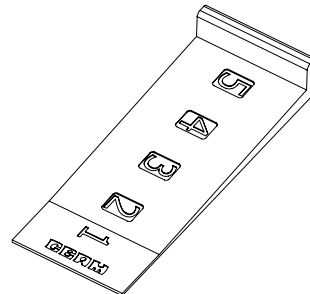
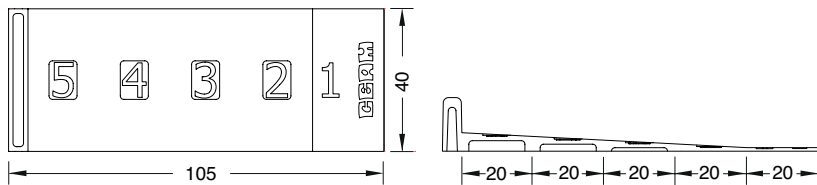

Adjustment keys

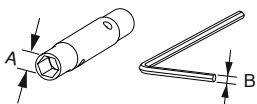

	A	B	Used for Models
BACKEY1	8	2,5	929, 1129, 1080, 1030, 1230S, 1430
BACKEY2	10	3	1131S, 1431

BACKEY Adjustment Keys
 Used to adjust the position of the door via the hinge's 3D adjustment axis points. Used to remove the hinge from its cup so the door can be removed and re-hung.

3D Adjustability Diagram

Adjustment guidelines

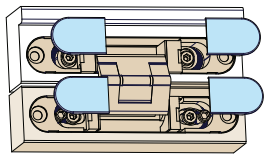

BAC1430
BAC929

Remove the covers

Invisible adjustable hinges for doors

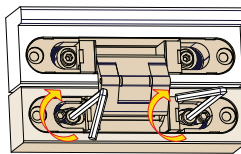
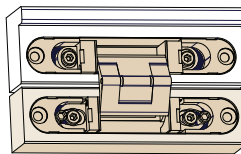
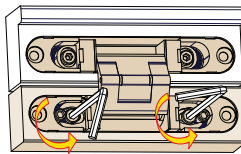
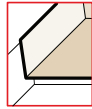
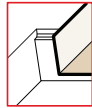
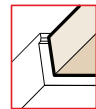

Vertical adjustment

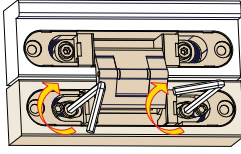
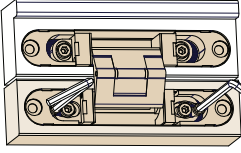
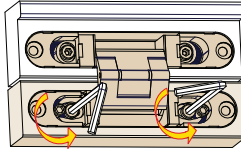
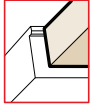
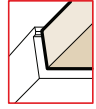

Depth adjustment

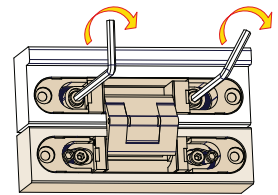
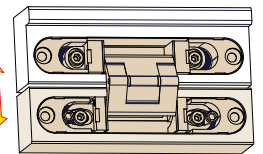
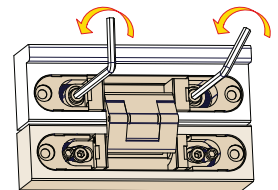
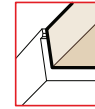
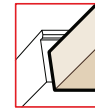
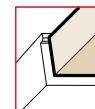

Horizontal adjustment

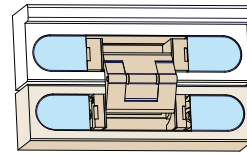

Replace the covers

3D Adjustability Diagram

Adjustment guidelines

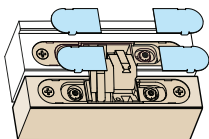

BAC1131S
BAC1230S
BAC1129
BAC1030 inox

Remove the covers

Invisible adjustable hinges for doors

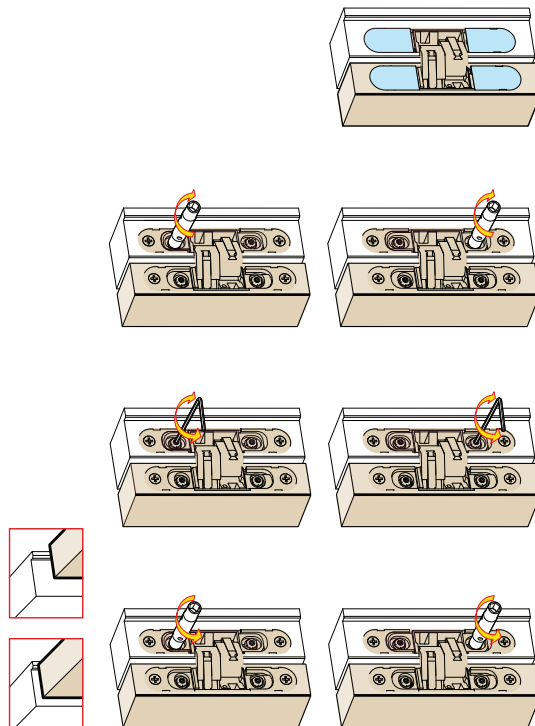
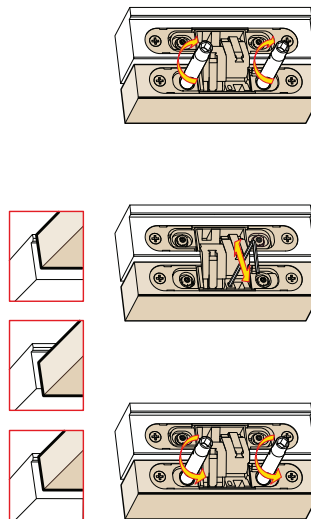
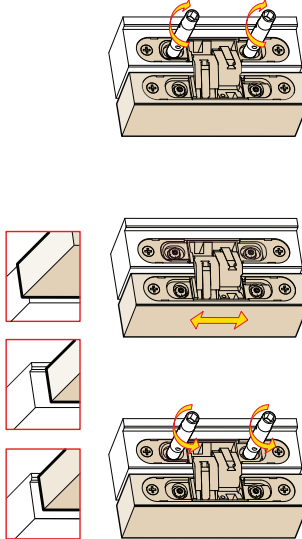
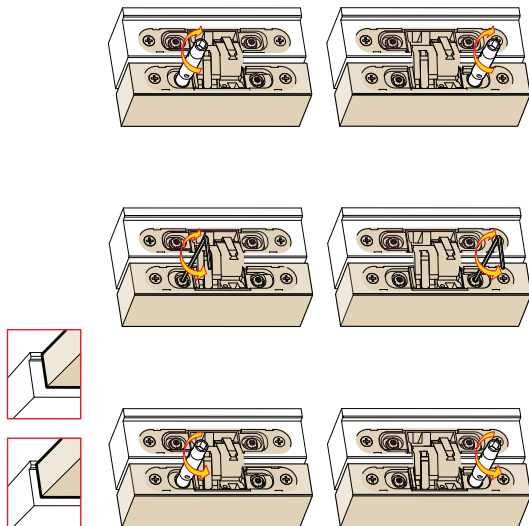

Replace the covers



Bellevue Architectural
954 Glen Huntly Road
Caulfield South Vic 3162

PH: (03) 9571 5666
Info@bellevuearch.com.au
www.bellevuearch.com.au

*Please note that all images in this document are used for illustrative purposes only.
Product specifications are subject to change without notice.

CEAM Concealed Hinge Range: Catalogue 1/21