

Installation Instructions for CAVILOCK CL400 ADA Magnetic Passage Handle

CL400 ADA Non-Latching Passage Handle

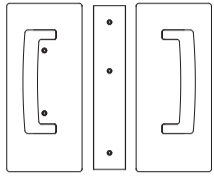

CL400 ADA Magnetic Latching Passage Handle

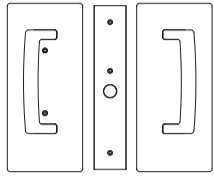

CL400 ADA Bi-Parting Passage (Non Latching)

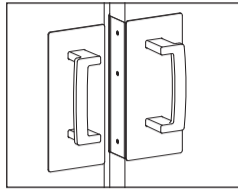

(Refer to Instruction 19)

Before you Start:

- This handle has been manufactured to specifications which **cannot** be altered by the installer. These include **Handle type, Configuration, Handing** and **Door thickness range**. Refer to the information printed on the *Side Handle* and *Chassis* boxes to ensure you have purchased a handle with the correct specifications for your situation. **If the specifications are incorrect you will need to exchange the handle.**
 - Component drawings have been provided. Please familiarise yourself with the components and check the package to ensure nothing is missing. **Note:** Components may vary slightly between configurations.
 - To ensure the handle latches accurately, it is essential that the door is adjusted for height and is parallel with the closing jamb when closed **before** installing the handle and striker.
 - This is a metric handle. **Accurate measurements are shown in millimetres. Conversions to inches are approximate.**
 - NZS4121:2001:** To comply with NZS4121:2001 the offset handle option must be used. The centre of the handle should be positioned between 900mm and 1200mm (1000mm optimal) above finished floor level. The door needs to be at least 910mm wide to allow minimum clear walk through of 760mm. There must be a 45mm clear space from edge of pull handle to the nearest door jamb when the door is both fully open and completely closed. A flat closing jamb is recommended. Consult local standards for guidelines relating to the specific project.
- USA ADA (American Disabilities Act) Guidelines:** Handle should be positioned between 34 - 48" above finished floor level. Allow a minimum of four inches for the protrusion of the door in the open position. This can be achieved by using track stops or blocking in the back of the pocket. Consult local standards for guidelines relating to the specific project.



WARNING: THE STRIKER CONTAINS A STRONG MAGNET

IRON FILINGS - Magnets will attract shavings from iron or ferrous metals which may be hard to remove. Keep the striker a safe distance away from these materials.

DANGER FOR CHILDREN - Magnets may cause serious injury if swallowed. Keep out of reach of children. **CRUSHING, BLISTERS AND CUTS** - Fingers may become caught between magnets resulting in crushing, blisters or cuts.

BREAKING OR CHIPPING - It is possible that magnets could chip or shatter on contact with other hard materials, resulting in chips flying off at high speed into someone's eye. Chips can also be very sharp - treat them as you would broken glass.

MAGNETICALLY SENSITIVE ITEMS - Keep a safe distance between the magnet and all objects that can be damaged by magnetism (e.g. mechanical watches, pacemakers, cell phones etc.).

DISPOSAL - Magnets should be disposed of carefully and in accordance with your local regulations.

Door Preparation

- Mark a line on the face of the door where the centre of the handle is to be positioned. Align the centre line on the *door cut out template* with the centre line on the door. Follow the instructions on the template.

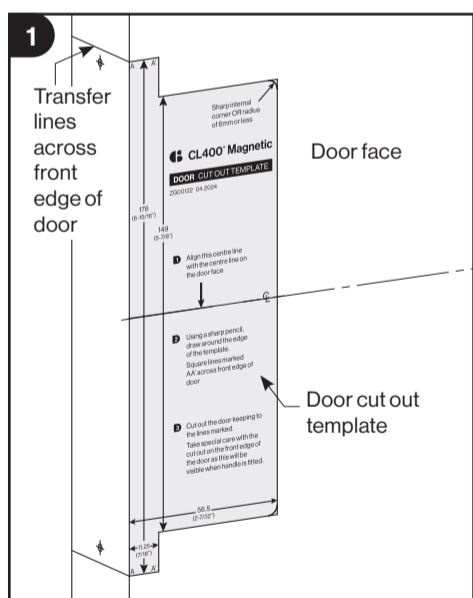

- Mark two holes in the centre of the door thickness in the positions shown. Using these marks, drill two 2.5mm (3/32") diameter holes to a depth of 35mm (1-3/8").

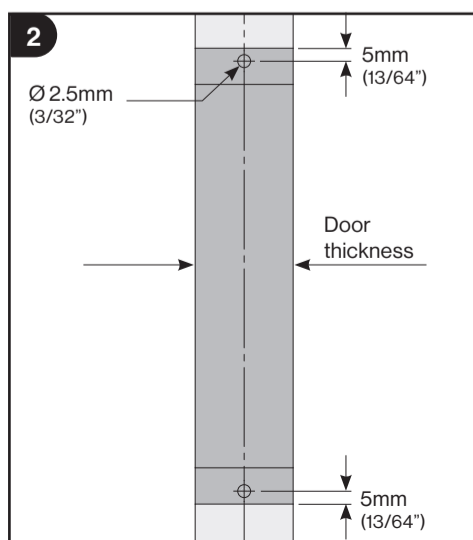

Fitting the Chassis

- Remove the *face plate screw* and *face plate* from the *chassis*. Align the chassis with the centre of the door thickness.

Screw the chassis to the door (using the 2x *chassis mounting screws*) through the slotted holes at the top and bottom of the chassis. **DO NOT** fully tighten the screws.

Realign the chassis with the centre of the door thickness. When happy with the chassis position, fully tighten the screws.

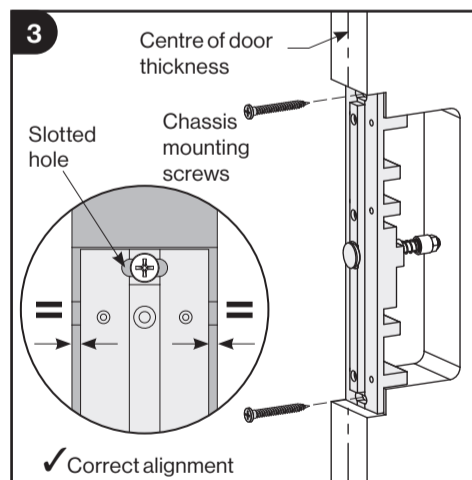

- Fit the 6x *side handle to chassis screws*. Leave a 3mm gap (1/8") between the underside of the screw head and the chassis.

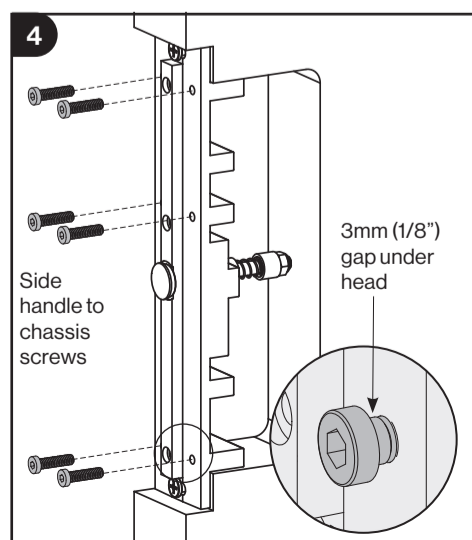

Component Drawings

Passage Side Handle Box

- a** Passage Side Handle (Left)
- b** Passage Side Handle (Right)

Passage Chassis Box

- c** Passage Face Plate
- d** Passage Chassis
- e** Plunger
- f** Plunger Nut
- g** Spring Reservoirs (2)
- h** Chassis Mounting Screws (2)
- i** Side Handle to Chassis Screws (6)
- j** Face Plate Screws (3)
- k** Handle Joining Screws (2)

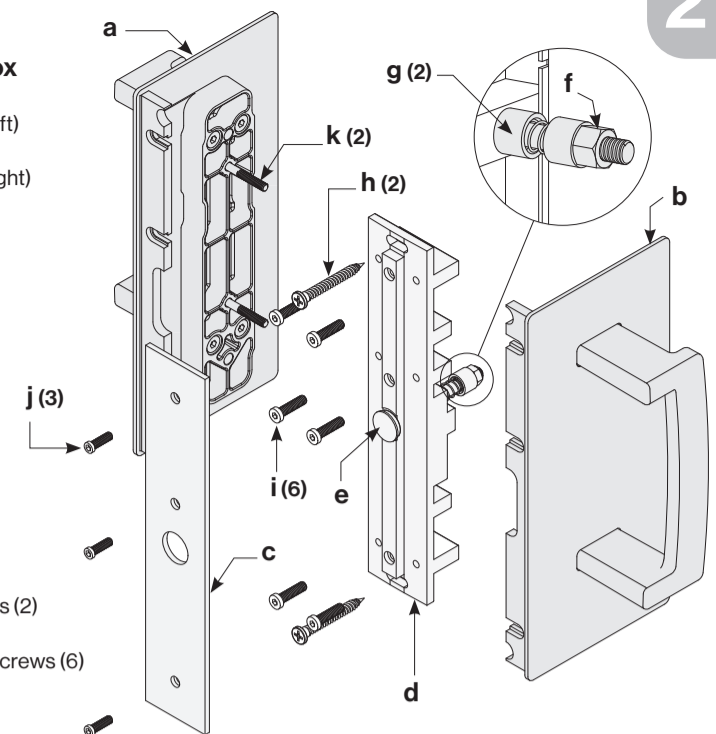

Note: Magnetic latching version shown above. Components will vary between the 'latching' and 'non-latching' version. **Offset handle option shown.**

Striker Box (magnetic latching version only)

- l** Striker Nuts (2)
- m** Striker Body
- n** Striker Mounting Wood Screws (4)
- o** Passage Striker Face Plate
- p** Striker Face Plate Screws (2)

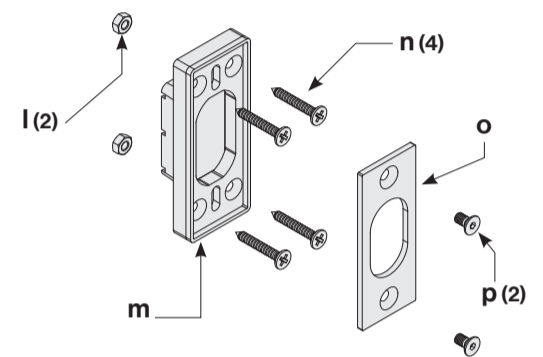

Tools (contained in Passage Chassis Box)

- q** Plunger Adjustment Spanners (2)
- r** CL400 Allen Key



Fitting the First Side Handle

- Select the *passage side handle* that has no visible screws (see diagram 5). Fit it to the chassis by sliding the front flange of the handle under the heads of the 3x *side handle to chassis screws*. Tighten the screws.

If you are fitting a **Non-Latching** or **Bi-Parting** handle, skip to **Step 16**; otherwise continue to **Step 6**.

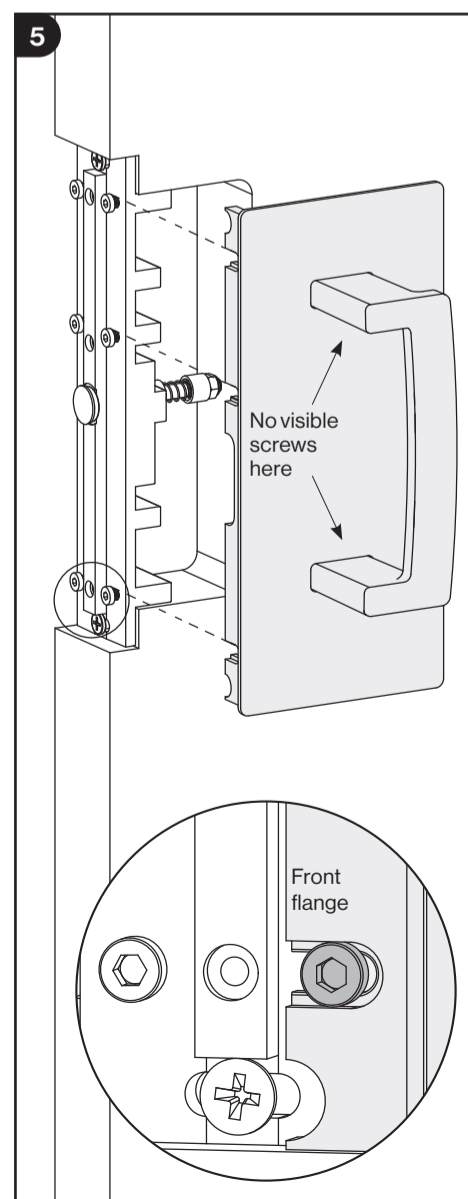

Fitting the Striker

- Close the door and mark a horizontal line on the closing jamb 61.75mm (2-7/16") down from the top edge of the side handle.

Note: these instructions are demonstrated on a recessed closing jamb, however, the same method applies to a flat closing jamb.

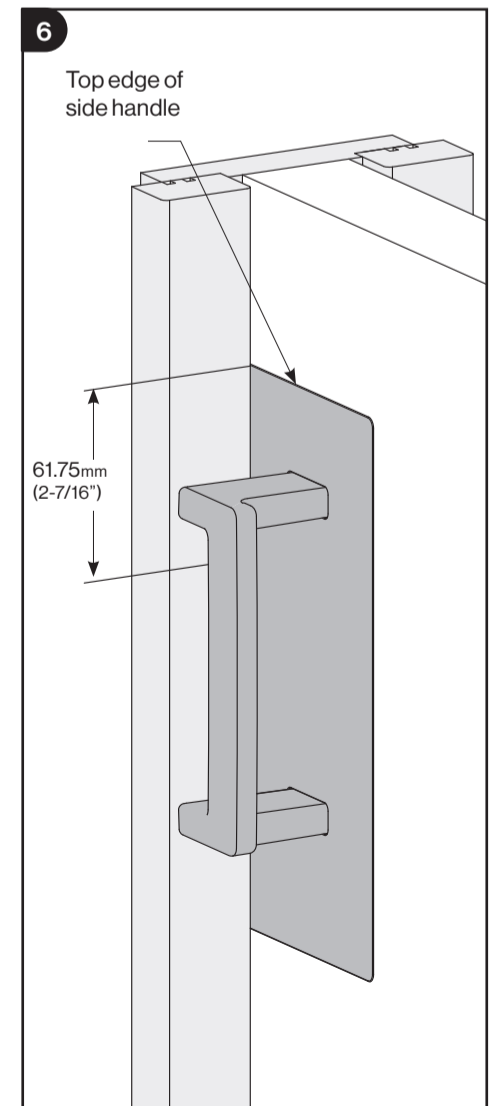

Fitting the Striker

7. Open the door. Transfer the horizontal line across the centre of the closing jamb. This line represents the top of the striker cut out.

A double-sided *striker cut out template* has been provided. Use the '**FLUSH striker template**' and instructions to router out the recess in the closing jamb.

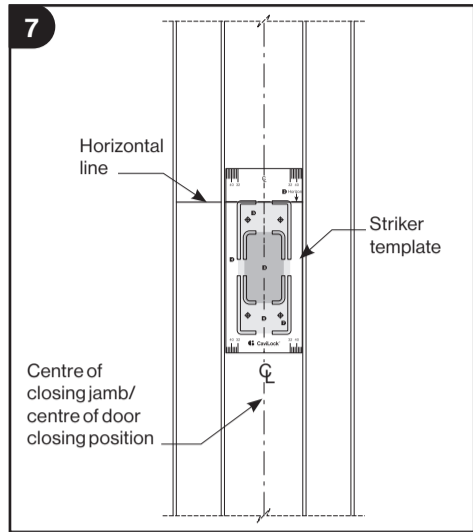

8. Remove the *striker* from its box. Remove the *striker face plate* from the *striker body*. Insert the 2x *striker nuts* into the recess in the back of the *striker body*.

Insert the 2x *striker face plate screws* through the slot in the front face of the *striker body* and into the *striker nuts*. Loosely tighten the screws.

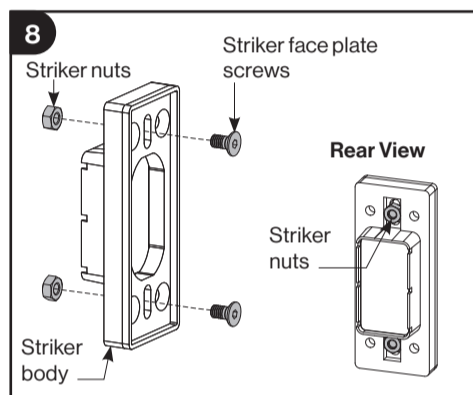

9. Insert the *striker body*, with the *striker face plate screws* and the *striker nuts* attached, into the cut out in the closing jamb. Screw the 4x *striker mounting wood screws* into the closing jamb.

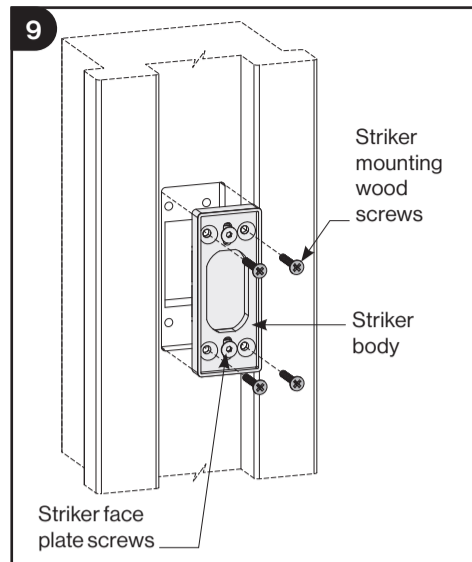

10. Remove the *striker face plate screws*. The *striker nuts* are now trapped in position.

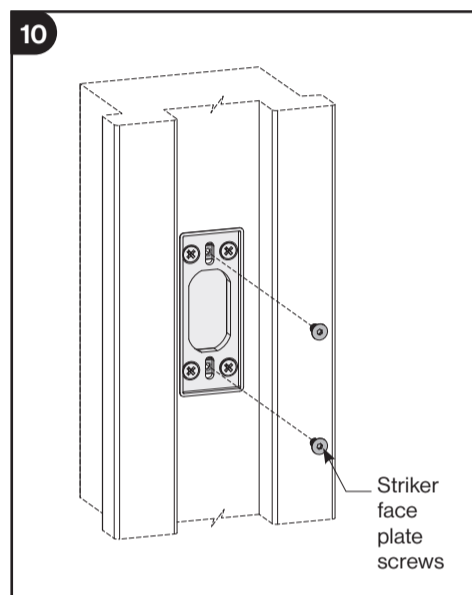

Fitting the Striker

11. Position the *striker face plate* in the centre of the *striker body* - this may need to be adjusted in the steps following. Insert the *striker face plate screws* and loosely tighten.

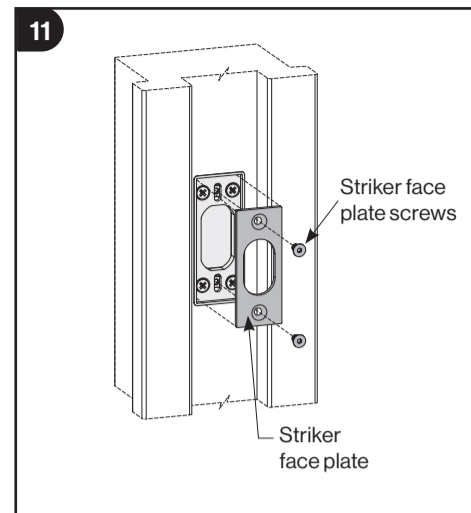

12. Close the door. When the *striker* is fitted correctly the magnet will draw the *plunger* forward. If this does not happen the *striker* is misaligned with the *plunger* (see below).

If the alignment is correct, tighten the screws and skip to **Step 14**; otherwise continue to **Step 13**.

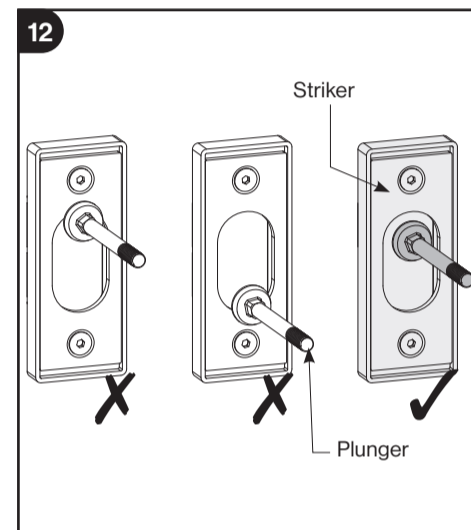

13. The *striker* allows 2.5mm (3/32") of adjustment in each direction when the *striker face plate* is fitted in the centre of the *striker body*.

To adjust the *face plate* position, loosen the *striker face plate screws* slightly and adjust the *face plate* up or down to allow the *plunger* to penetrate the *striker face plate*. If the *plunger* still fails to penetrate the *striker face plate*, the *door height* may need to be adjusted.

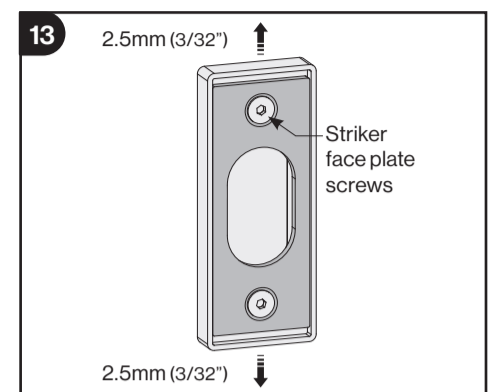

Adjusting the Plunger

14. Manually push the *plunger* forward until there is no gap between *spring reservoir one* (SR1) and *spring reservoir two* (SR2).

Restrain the *plunger nut* using the **large** end of one of the two identical supplied *spanners*.

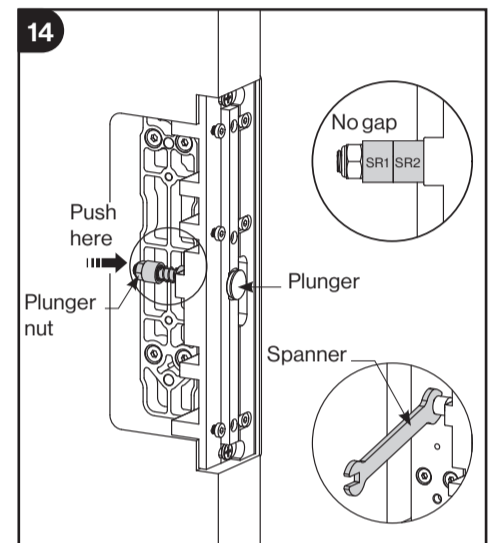

Adjusting the Plunger

15. Place the **small** end of the second *spanner* across the flats under the head of the *plunger*. Keep the *spanner* restraining the *plunger nut* **stationary** while turning the second *spanner* **clockwise**.

Continue to turn the *spanner* until there is no longer a gap between the *spanner* and the *chassis*.

Now turn the *spanner* **anti clockwise** half a turn.

The *plunger* should now be adjusted correctly. Slide the door closed to check.

Adjust if necessary.

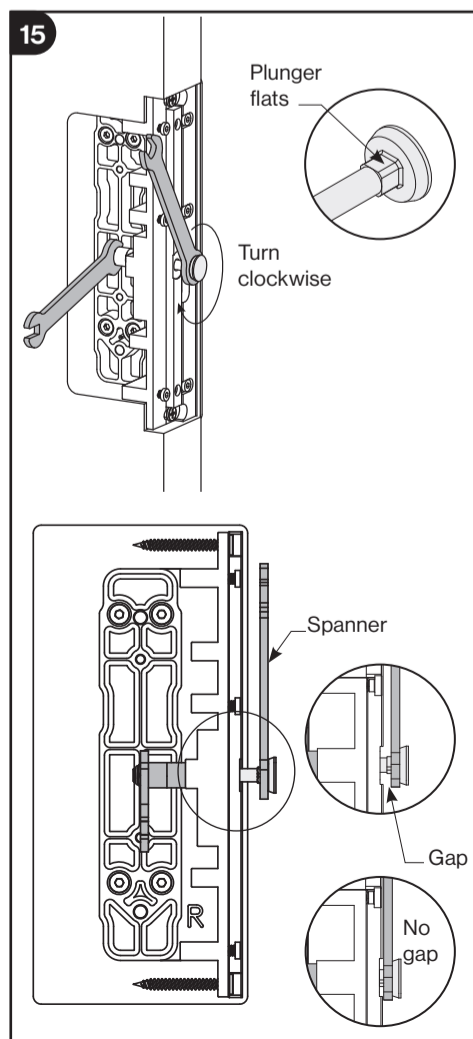

Fitting the Remaining Side Handle

16. Fit the remaining *side handle* (with visible *handle joining screws* fitted) to the *chassis* by sliding the *front flange* of the *handle* under the heads of the 3x *side handle to chassis screws*. Tighten the screws.

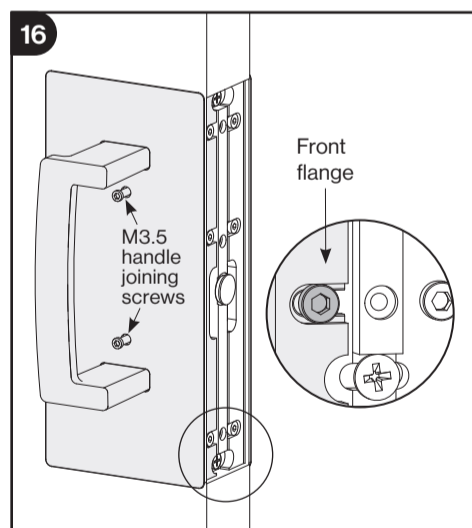

17. Use the ball end of the *CL400 Allen key* to tighten the 2x *handle joining screws*.

Use the other end of the *Allen key* to firmly tighten the screws.

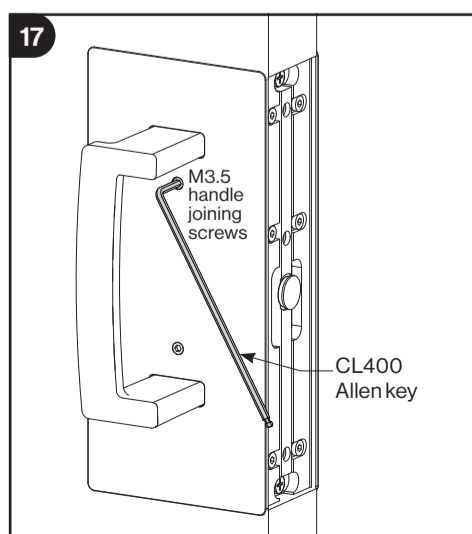

Fitting the Face Plate

18. Fit the *passage face plate* to the *chassis* using the 3x *face plate screws*.

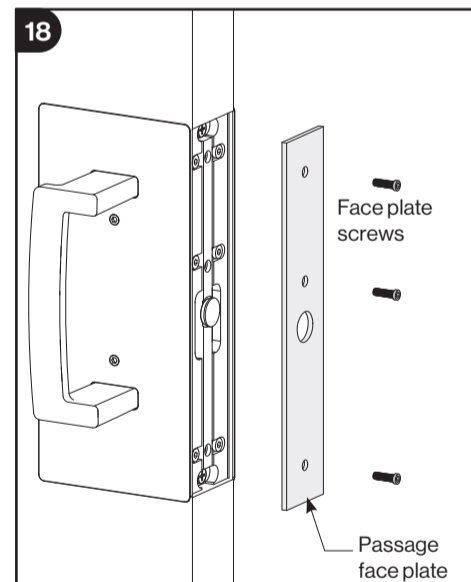

Bi-Parting Handles

19. If you are installing a **CL400 Bi-Parting - Passage (Non Latching)** handle, both handles are the same and you can simply repeat the *Passage Handle installation instructions* for the second door.

Ignore any reference to the *striker* or *plunger*.

© Cavity Sliders Limited. **CAVILOCK® CL400® MAGNETIC** (O.D. 2013) **ADA PASSAGE INSTRUCTIONS.** ZG00108 - 05.2024
All copyright and other property in this document is reserved by Cavity Sliders Limited. Details and specifications are subject to change without notice. Whilst all care is taken to ensure the accuracy of all information, no responsibility will be accepted for any errors or omissions.
NZ Patent No. 423284; EU Patent No. 004565315-0002

Cavity Sliders™

www.cavitysliders.com

