

Installation Instructions for CAVILOCK CL400 ADA Magnetic Privacy Handle

CL400 ADA Snib/Snib Privacy Handle

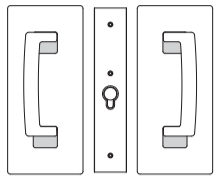

CL400 ADA Snib/Emergency Privacy Handle

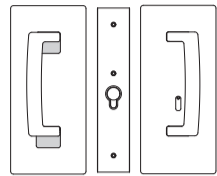

Before you Start:

- This handle has been manufactured to specifications which **cannot** be altered by the installer. These include **Handle type, Configuration, Handing and Door thickness range**. Refer to the information printed on the *Side Handle* and *Chassis* boxes to ensure you have purchased a handle with the correct specifications for your situation. **If the specifications are incorrect you will need to exchange the handle.**
 - Security:** The CL400 handle should not be installed in situations where a high level of security is required, e.g. external entry points or high security internal doorways.
 - Component drawings have been provided. Please familiarise yourself with the components and check the package to ensure nothing is missing. **Note: Components may vary slightly between configurations.**
 - To ensure the handle latches accurately, it is essential that the door is adjusted for height and is parallel with the closing jamb when closed **before** installing the handle and striker.
 - This is a metric handle. **Accurate measurements are shown in millimetres. Conversions to inches are approximate.**
 - NZS4121:2001:** To comply with NZS4121:2001 the offset handle option must be used. The centre of the handle should be positioned between 900mm and 1200mm (1000mm optimal) above finished floor level. The door needs to be at least 910mm wide to allow minimum clear walk through of 760mm. There must be a 45mm clear space from edge of pull handle to the nearest door jamb when the door is both fully open and completely closed. A flat closing jamb is recommended or CS can supply a recessed closing jamb to suit. The supplied 'Down to Lock' sticker must be positioned as close as possible to the handle. Consult local standards for guidelines relating to the specific project.
- USA ADA (American Disabilities Act) Guidelines:** Handle should be positioned between 34 - 48" above finished floor level. Allow a minimum of four inches for the protrusion of the door in the open position. This can be achieved by using track stops or blocking in the back of the pocket. Consult local standards for guidelines relating to the specific project.

WARNING: THE STRIKER CONTAINS A STRONG MAGNET IRON FILINGS - Magnets will attract shavings from iron or ferrous metals which may be hard to remove. Keep the striker a safe distance away from these materials.

DANGER FOR CHILDREN - Magnets may cause serious injury if swallowed. Keep out of reach of children.

CRUSHING, BLISTERS AND CUTS - Fingers may become caught between magnets resulting in crushing, blisters or cuts.

BREAKING OR CHIPPING - It is possible that magnets could chip or shatter on contact with other hard materials, resulting in chips flying off at high speed into someone's eye. Chips can also be very sharp - treat them as you would broken glass.

MAGNETICALLY SENSITIVE ITEMS - Keep a safe distance between the magnet and all objects that can be damaged by magnetism (e.g. mechanical watches, pacemakers, cell phones etc.).

DISPOSAL - Magnets should be disposed of carefully and in accordance with your local regulations.

Door Preparation

- Mark a line on the face of the door where the centre of the handle is to be positioned. Align the centre line on the *door cut out template* with the centre line on the door. Follow the instructions on the template.

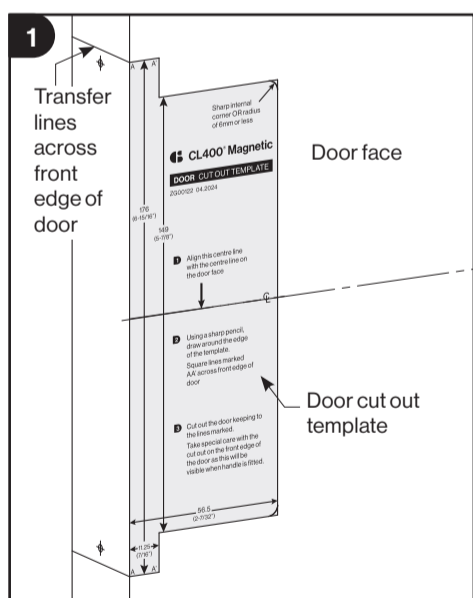

- Mark two holes in the centre of the door thickness in the positions shown. Using these marks, drill two 2.5mm (3/32") diameter holes to a depth of 35mm (1-3/8").

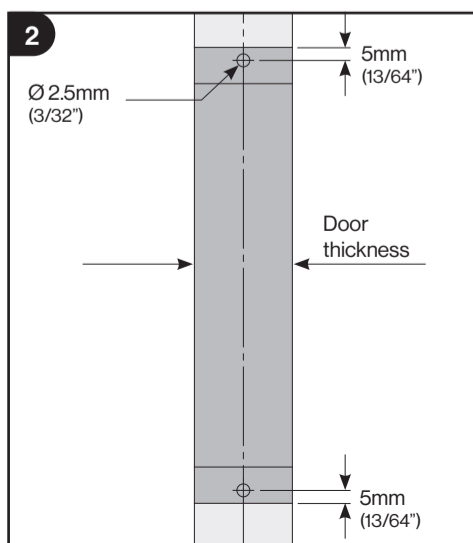

Fitting the Chassis

- Remove the *face plate screw* and *face plate* from the *chassis*. Align the chassis with the centre of the door thickness.

Screw the chassis to the door (using the 2x *chassis mounting screws*) through the slotted holes at the top and bottom of the chassis. **DO NOT** fully tighten the screws.

Realign the chassis with the centre of the door thickness. When happy with the chassis position, fully tighten the screws.

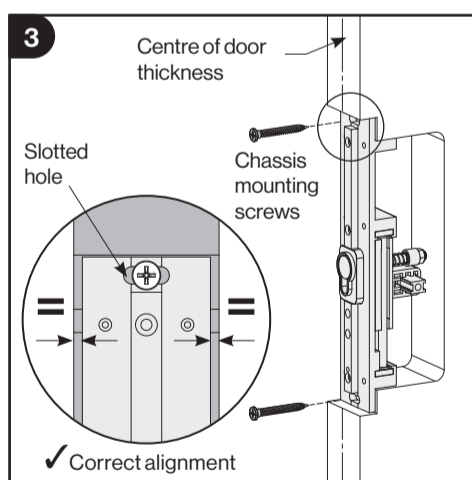

- Fit the 6x *side handle to chassis screws*. Leave a 3mm (1/8") gap between the underside of the screw head and the chassis.

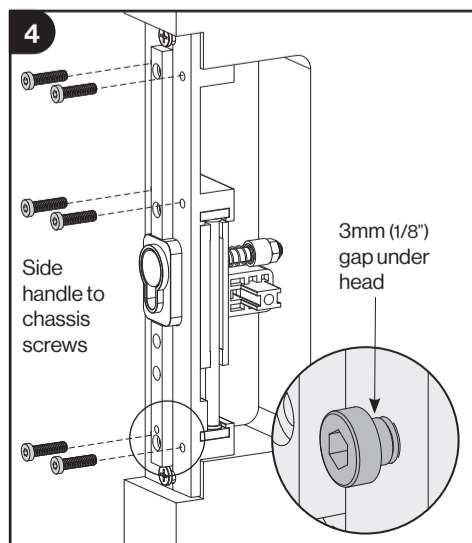

Component Drawings

Privacy Side Handle Box

- a** Privacy Side Handle (Left)
- b** Privacy Side Handle (Right)

Privacy Chassis Box

- c** Privacy Face Plate
- d** Privacy Chassis
- e** Plunger
- f** Shroud
- g** Plunger Nut
- h** Spring Reservoirs (2)
- i** Chassis Mounting Screws (2)
- j** Side Handle to Chassis Screws (6)
- k** Face Plate Screws (3)
- l** Emergency Release Button (Where Applicable)
- m** Handle Joining Screws (2)
- n** Clip-In Indicators (2)

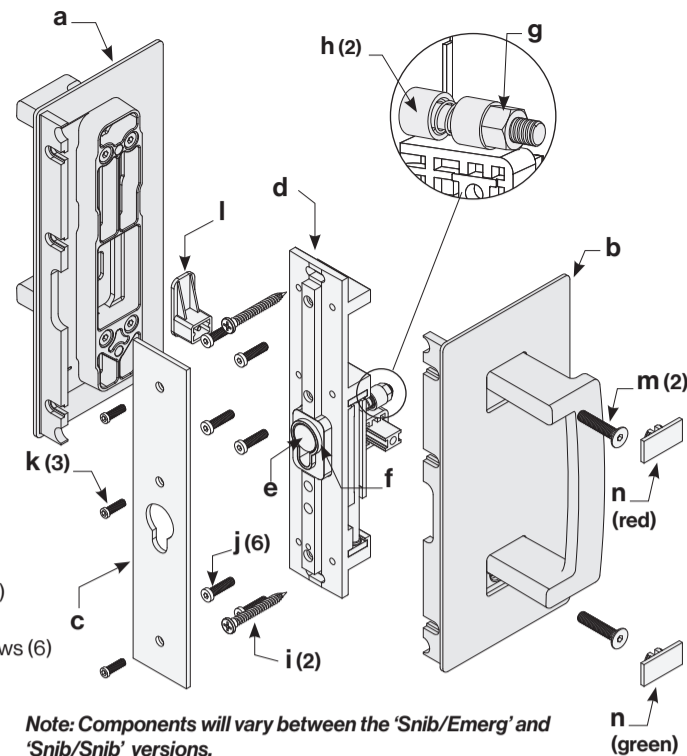

Striker Box

- o** Striker Nuts (2)
- p** Striker Body
- q** Striker Mounting Wood Screws (4)
- r** Privacy Striker Face Plate
- s** Striker Face Plate Screws (2)

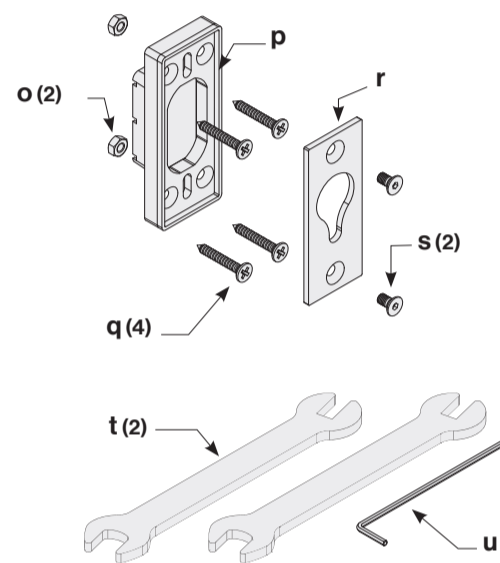

Tools (contained in Privacy Chassis Box)

- t** Plunger Adjustment Spanners (2)
- u** CL400 Allen Key

Fitting the First Side Handle

- Fit the *snib privacy side handle* to the chassis as follows (if installing a snib/snib privacy handle install **ONE** of the side handles only):

- a.** Align the recess in the back of the snib button with the arm of the *locking slider*.
- b.** Slide the front flange of the handle under the heads of the 3x *side handle to chassis screws*. Tighten the screws.

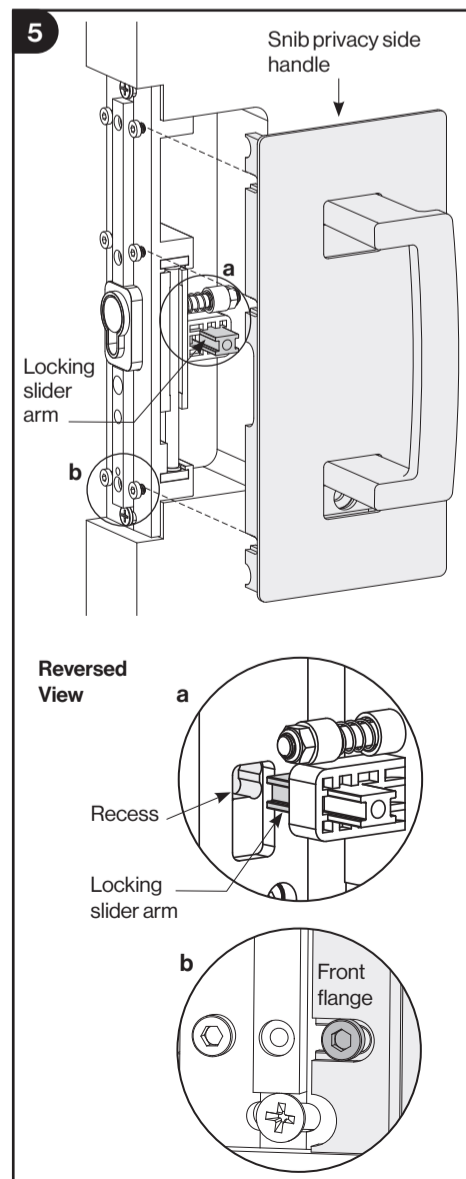

Fitting the Striker

- Close the door and mark a horizontal line on the closing jamb 61.75mm (2-7/16") down from the top edge of the side handle.

Note: these instructions are demonstrated on a recessed closing jamb, however, the same method applies to a flat closing jamb.

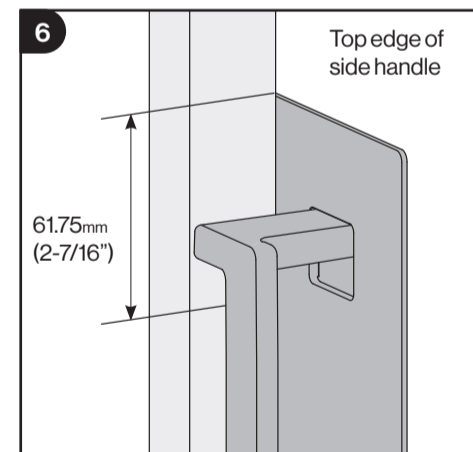

- Open the door. Transfer the horizontal line across the centre of the closing jamb. This line represents the top of the striker cut out. A double-sided *striker cut out template* has been provided:
 - Use template labelled '**FLUSH striker template**'.

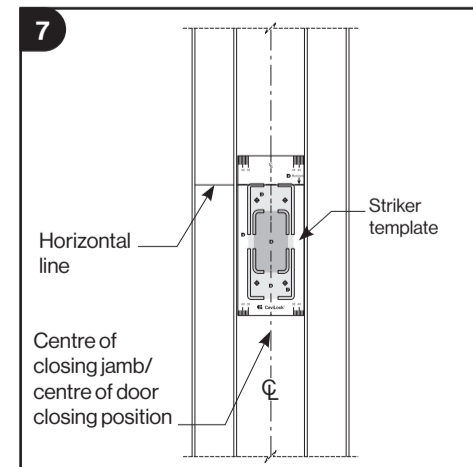

Fitting the Striker

8. Remove the striker from its box. Remove the *striker face plate* from the *striker body*. Insert the 2x *striker nuts* into the recess in the back of the striker body.

Insert the 2x *striker face plate screws* through the slot in the front face of the striker body and into the striker nuts. Loosely tighten the screws.

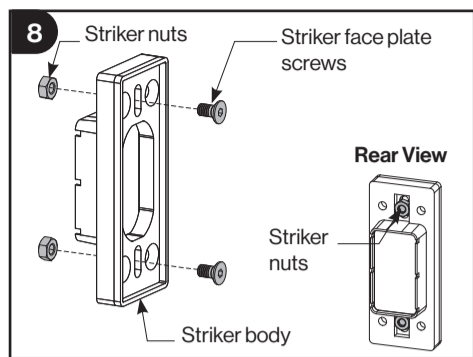

9. Insert the striker body, with the striker face plate screws and the striker nuts attached, into the cut out in the closing jamb.

Screw the 4x *striker mounting wood screws* into the closing jamb.

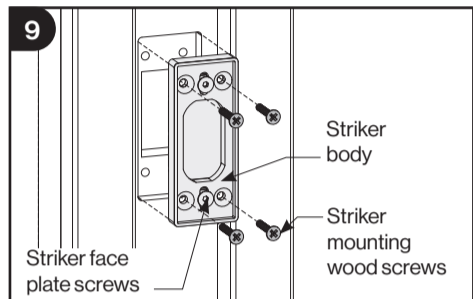

10. Remove the striker face plate screws. The striker nuts are now trapped in position.

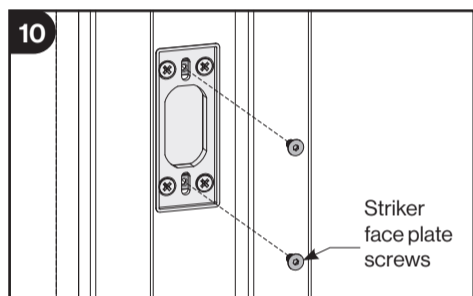

Fitting the Remaining Side Handle

17. Fit the remaining side handle to the chassis by sliding the front flange of the handle under the heads of the 3x *side handle to chassis* screws. Tighten the screws.

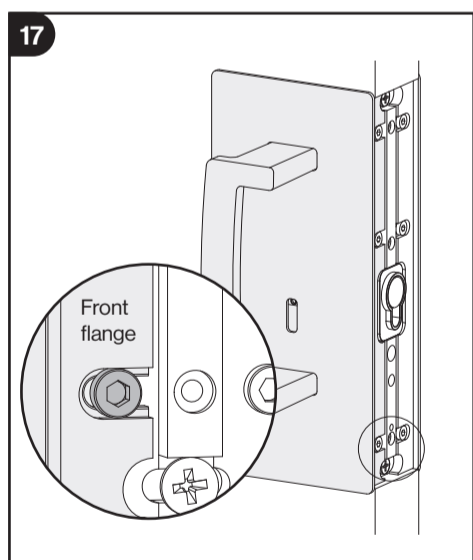

Fitting the Face Plate

18. Fit the *privacy face plate* to the chassis using the 3x *face plate screws*.

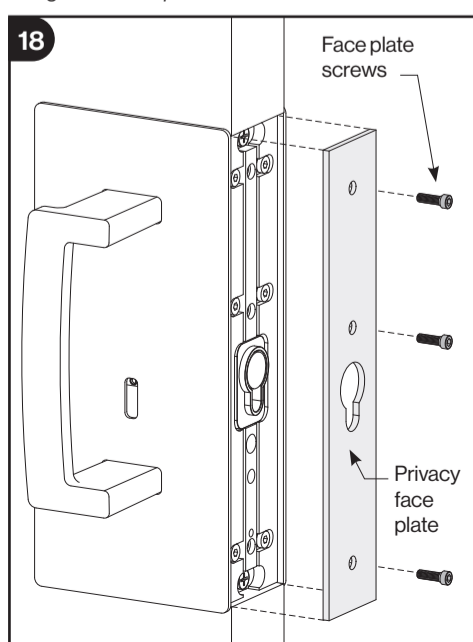

11. Position the *striker face plate* in the centre of the *striker body* - this may need to be adjusted in the steps following. Insert the *striker face plate screws* and loosely tighten.

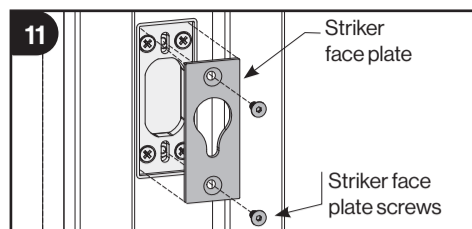

12. Close the door. When the striker is fitted correctly the magnet will draw the plunger forward. If this does not happen the striker is misaligned with the plunger (see below). If the alignment is correct, tighten the screws and skip to **Step 14**; otherwise continue to **Step 13**.

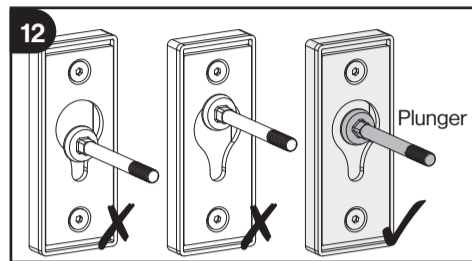

13. The striker allows 2.5mm (3/32") of adjustment in each direction when the *striker face plate* is fitted in the centre of the *striker body*.

To adjust the face plate position, loosen the *striker face plate screws* slightly and adjust the face plate up or down to allow the *plunger* to penetrate the *striker face plate*. If the *plunger* still fails to penetrate the *striker face plate*, the door height may need to be adjusted.

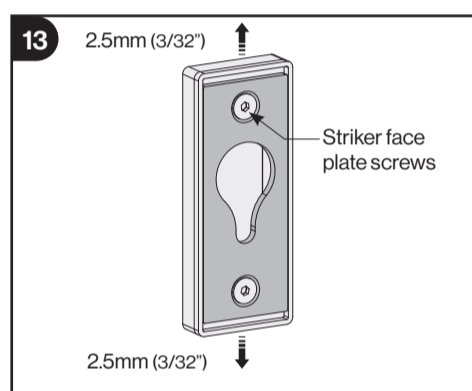

Fixing the Side Handle

19. With the pull handle in the 'unlocked' position, insert one of the *handle joining screws* through the bottom hole in the side handle and tighten.

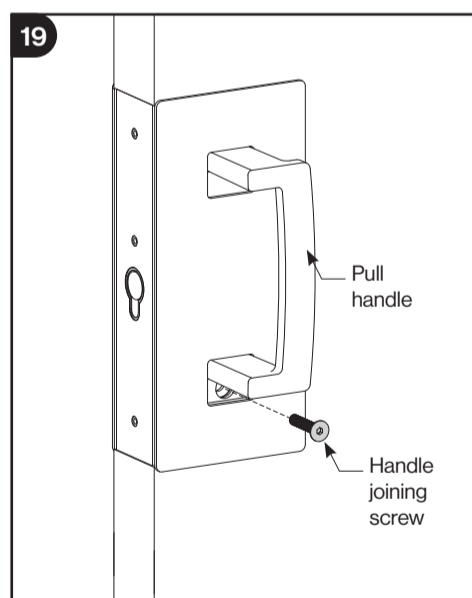

20. Close the door and push the *pull handle* down into the 'locked' position. Insert the second *handle joining screw* through the top hole and tighten.

While the door is closed, lock and unlock the door to check the action. Adjust if necessary.

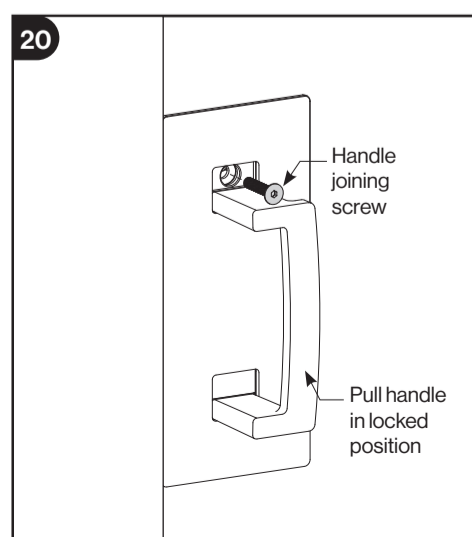

5

Adjusting the Plunger

14. Manually push the *plunger* forward until there is no gap between *spring reservoir one* (SR1) and *spring reservoir two* (SR2).

Restrain the *plunger nut* using the **large** end of one of the two identical supplied *spanners*.

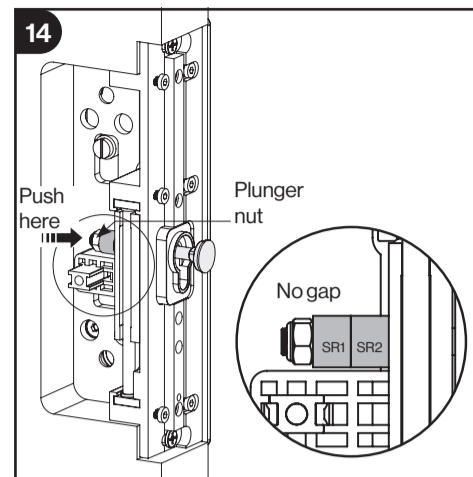

15. Place the **small** end of the second *spanner* across the flats under the head of the *plunger*.

Keep the *spanner* restraining the *plunger nut* **stationary** while turning the second *spanner* **clockwise**. Continue to turn the *spanner* until there is no longer a gap between the *spanner* and the *shroud face*.

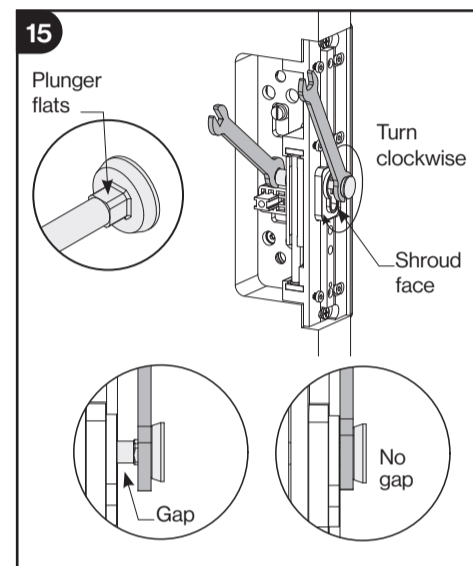

Now turn the *spanner* **anti clockwise** half a turn. The *plunger* should now be adjusted correctly. Slide the door closed to check that it latches. If the *snib* button is hard to push down or the *plunger* doesn't engage with the *striker*, adjust as necessary.

6

Fitting Emergency Release

16. If installing a *snib/snib* or a *snib one side privacy handle* proceed to **Step 17**, otherwise, fit the *emergency release button* (with the *spring* attached) over the *locking slider arm*.

Note: the *locking slider arm* may have been pre-cut depending on the width of the door. The drawing below demonstrates a cut *slider arm*.

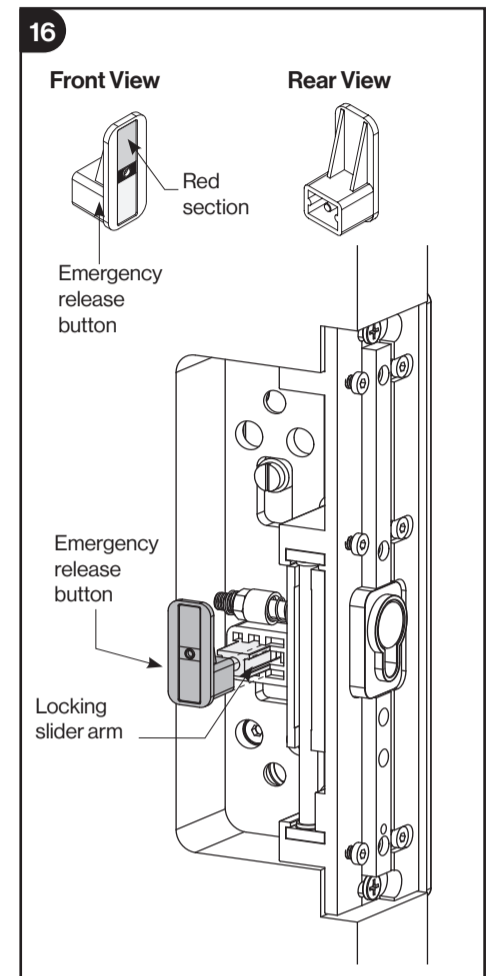

18

7

Fitting the Clip-in Indicators

Warning: it is **very important** that you follow the **next instructions carefully** as the *clip-in indicator* **cannot be easily removed once installed**.

21. With the *pull handle* down in the 'locked' position, insert the **RED** *clip-in indicator* into the TOP hole.

Note: the *indicator* is designed to remain in place permanently and may require some force to insert.

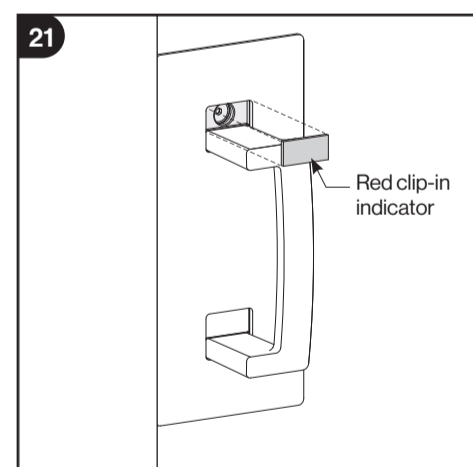

22. Lift the *pull handle* up to unlock it.

Insert the **GREEN** *clip-in indicator* into the BOTTOM hole.

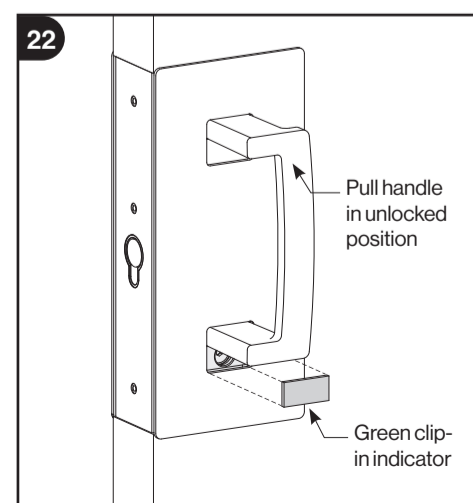

23. If installing a handle with *snib* both sides, fit the *clip-in indicators* to both sides.

Fitting the Sticker

24. The supplied '*Down to Lock*' *sticker* should be positioned on the door or adjacent wall near the *snib* side of the handle.

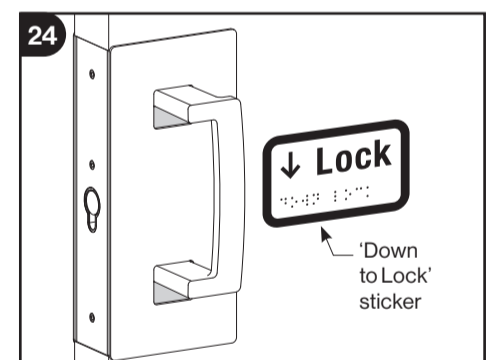

Removing the Handle

25. If you need to **remove the handle from the door at a later date**, drill through the *clip-in indicators* to expose the *handle joining screws*. You will need to purchase replacement *indicators* if you are refitting the handle.

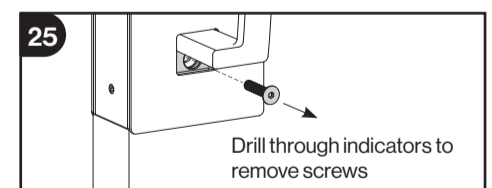

© Cavity Sliders Limited.
CAVILOCK™ CL400™ MAGNETIC (O.D. 2013)
ADA PRIVACY INSTRUCTIONS.
ZG00110 - 05.2024
All copyright and other property in this document is reserved by Cavity Sliders Limited. Details and specifications are subject to change without notice. Whilst all care is taken to ensure the accuracy of all information, no responsibility will be accepted for any errors or omissions.
NZ Patent No. 423284; EU Patent No. 004565315-0002

Cavity Sliders™

www.cavitysliders.com



8