

HB 1260

RECESSED DOUBLE OUTWARD HANGING BLIND BOX EXTRUSION

Recessed Double Outward Hanging Blind Box Extrusion is a sleek flush mounted to ceiling plaster board (10mm or 13mm), primarily for two rows of automated blinds and screens for example where both sheer and black out blinds are required.

Double Blind Box Extrusion – sold in 3m and 4.2m lengths only.

Materials: Extruded Aluminium, available in raw unfinished aluminium only. Raw extrusion can be powdercoated or custom finished by client. We recommend cutting to size before colour finishing is undertaken to ensure edges are coloured and cutting does not chip powder coating. For matching end caps please see the HB 1265 for where the double box is used and the HB 1267 where a single length only is installed.

All Halliday + Baillie extrusions are sold in specific lengths. We do however supply these lengths 80mm longer than the stated purchase length. The additional amount is to cover any damage to ends from the cutting process and to allow 25-40mm at either end to hold or jig the extrusion for either powdercoating or anodising. We strongly recommend cutting ends to provide a clean finish before colouring and/or before installation.

Please note: blinds and any automation mechanisms not included. If specifying for manual blinds, the cover flap will need to be made approximately 30mm shorter at each end to allow for cord access. This is the responsibility of the client.

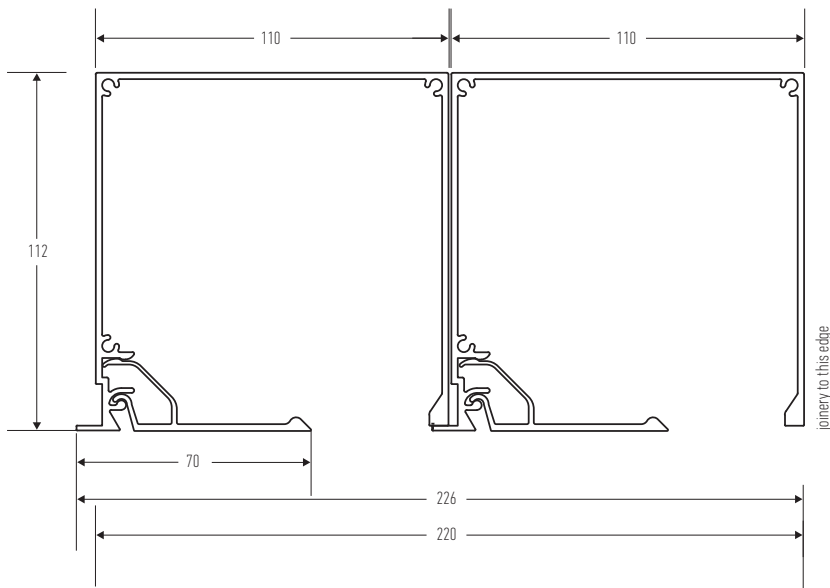
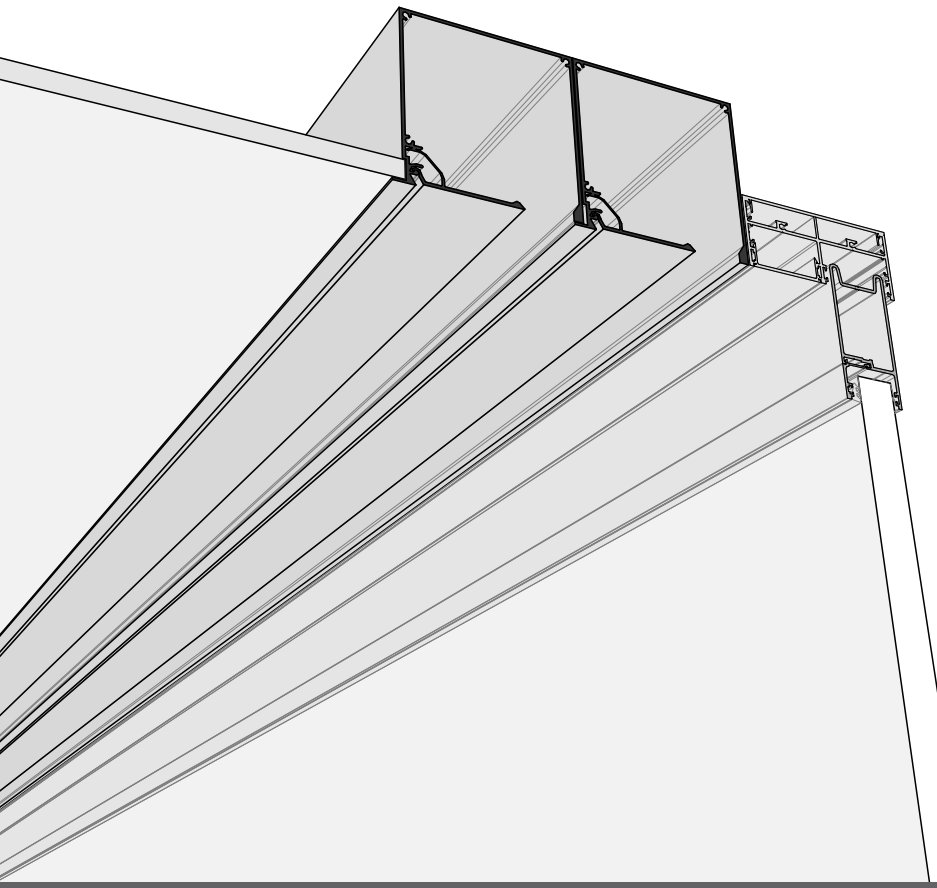

Double Outward Hanging Blind Box

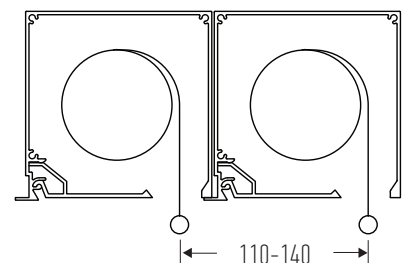

HB 1260

HB 1265 END CAP

Designed and manufactured in New Zealand. For more information, installation templates, and measured drawings of this product and others please visit : www.hallidaybaillie.com or contact your authorized Halliday + Baillie dealer. All information subject to change.