

**halliday
baillie**

HB 1290

NARROW SINGLE BOX EXTRUSION

The Full Narrow Box Extrusion is a sleek extrusion designed specifically to work with the existing family of H+B blind box extrusions, with curtains in mind. Mounted flush to ceiling plaster board (10mm or 13mm), this extrusion can be used on its own or in conjunction with a single length of the HB 1260 Blind Box Extrusion profile.

Full Box Blind Extrusion – sold in 3m and 4.2m lengths only.

Materials: Extruded Aluminium, available in raw unfinished aluminium only. Raw extrusion can be powdercoated or custom finished by client. We recommend cutting to size before colour finishing is undertaken to ensure edges are coloured and cutting does not chip powder coating. For matching end caps please see your local Halliday + Baillie representative.

All Halliday + Baillie blind box extrusions are sold in specific lengths. We do however supply these lengths 80mm longer than the stated purchase length. The additional amount is to cover any damage to ends from the cutting process and to allow 25-40mm at either end to hold or jig the extrusion for either powder coating or anodising. We strongly recommend cutting ends to provide a clean finish before colouring and/or before installation.

Please note: curtains and any automation mechanisms not included.

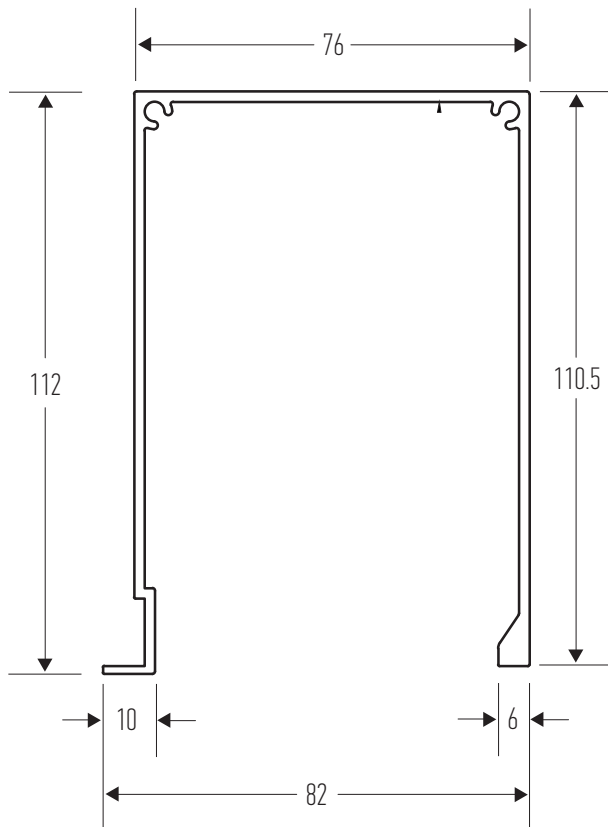

Designed and manufactured in New Zealand. For more information, installation templates, and measured drawings of this product and others please visit : www.hallidaybaillie.com or contact your authorized Halliday + Baillie dealer. All information subject to change.