



**halliday  
baillie**

## HB 638 SERIES

### SLIDING DOOR ENTRY LOCK SET WITH END PULL – 55mm BACKSET

The Halliday + Baillie HB 638 sliding door lock set series allows several lock functions for sliding doors requiring keyed security. This series uses a "snib" (a slide block that acts like a traditional thumb turn) to throw the bolt. The HB 638 body has the additional function of a swing out end pull when used in pocket door situations. Can be used on both interior and exterior doors.

Sliding the snib operates the bolt unless the cylinder is engaged. The key cylinder will lock the snib in place and does not activate the bolt. Please note that Euro Profile Cylinders are used with these sets and are sold separately. Various configurations are available as below.

Flush Pull Material : Diecast Zinc and Brass

Lock Body Material : Diecast Zinc, Brass, 316 Stainless Steel

Backset : 55mm

Minimum door thickness : 38mm

Flush pulls : 250 x 36 x 13

Internal grip depth : 36mm

Suitable for timber or wide profile aluminium doors

Standard HB 638 series set includes :

- HB 638 Series Lock Body
- Two HB 668 Flush Pulls
- HB 604 Fixing Kits (one set for HB 636)
- Strike and Dust Box
- Two spindle lengths (please specify door thickness for doors over 50mm)
- Fasteners
- Cylinder ordered separately for door thickness

Configurations :

HB 638 : Key/Snib Both Sides

HB 637 : Key/Snib In, Blank Out

HB 636 : Key/Snib In, No Pull Out

Available in all standard Halliday + Baillie finishes, see finishes sheet for further details.

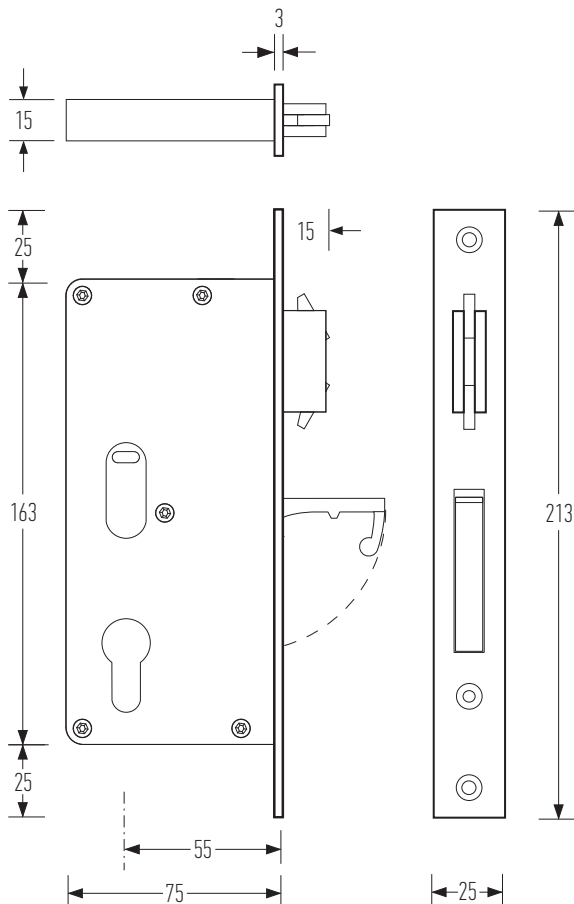

Designed and manufactured in New Zealand. For more information, installation templates, and measured drawings of this product and others please visit : [www.hallidaybaillie.com](http://www.hallidaybaillie.com) or contact your authorized Halliday + Baillie dealer. All information subject to change.