

**halliday
baillie**

HB 720

MAGNETIC DOOR STOP

The Halliday + Baillie floor-mounted HB 720 Cube Door Stop provides an iconic solution for when a mechanical hold open function is required. The door-mounted steel Keeper is finished to match and nests perfectly into the magnet providing a strong force—perfect for large doors.

Suitable for interior or covered exterior use. Includes steel Keeper (below), and all fasteners.

Material : Aluminium-alloy, stainless steel fasteners, steel Keeper and magnets.

Dimensions : 38 x 38 x 51 H (base only excluding magnet)

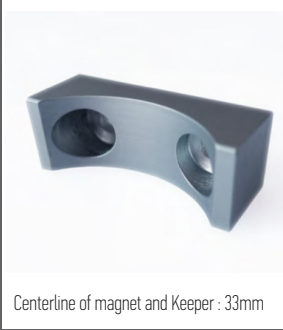
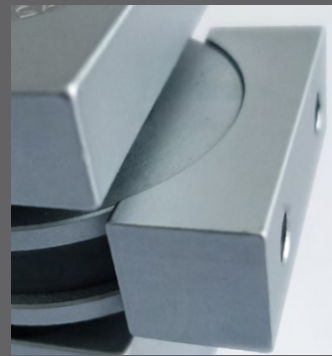
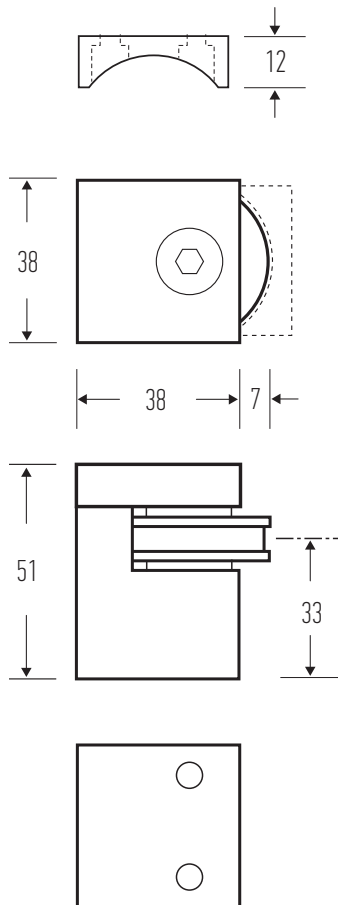

Centerline of magnet and Keeper : 33mm

HB 765 (order separately)

SOLID ELEVATING BASE FOR HB 720

Dimensions : 51 x 51 x 25 H

Centerline of magnet with base : 58mm

Available in all standard Halliday + Baillie finishes. See finishes sheet for further details.

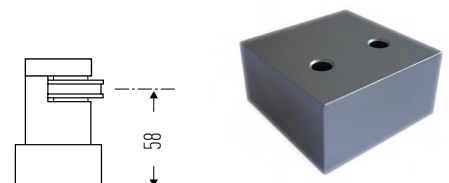

Designed and manufactured in New Zealand. For more information, installation templates, and measured drawings of this product and others please visit : www.hallidaybaillie.com or contact your authorized Halliday + Baillie dealer. All information subject to change.