

Install Instructions

Pull Handle (Timber Door)

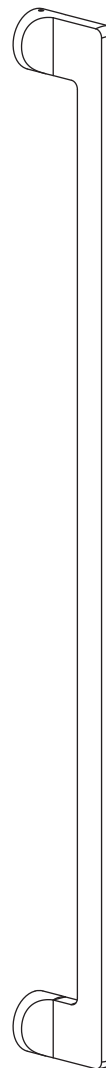

Scan for AU
Warranty



Scan for NZ
Warranty



Scan for
Product &
Finish Care
Information



*Image used for illustration purposes only.

Contact Us Southern Design Group

Australia
14 - 16 Stepney Street,
Stepney, South Australia 5069
P: +61 (0)8 8362 1133
info@iver.com.au
iver.com.au

New Zealand
P: +64 (0)6 359 0008
info@iver.co.nz
iver.co.nz

SDG Trading Pty Ltd
trading as Iver
ACN 008 154 041 | ABN 18 008 154 041

1. Determine the Centre to Centre (CTC) measurement of your pull handle

- 1.1. This is the distance from the middle of the top fixing point to the middle of the bottom fixing point. If unsure, this measurement can be found in the product description on the box and in the specifications on our website. (Figure 1)

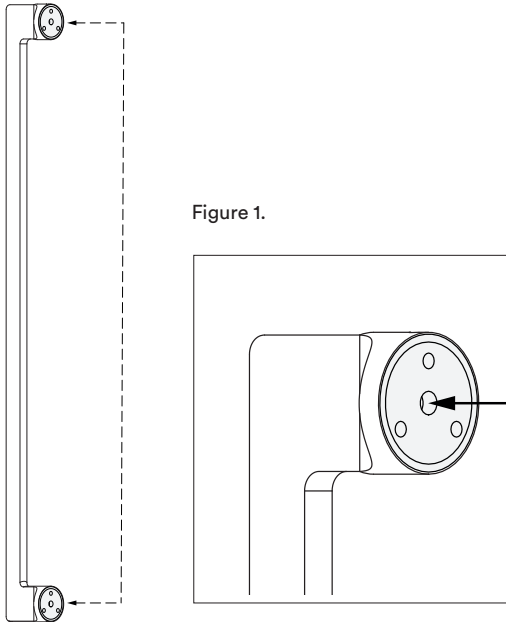

Figure 1.

IMPORTANT:

Please install this door hardware in the following order to ensure its warranty is not voided.

1. Install the door hardware on raw / unfinished door using the instructions provided.
2. Remove door hardware and store safely. Do not place painters tape or masking tape over the product. The tape will damage the finish.
3. Paint / finish door.
4. Reinstall hardware.



Please recycle me after use

2. Marking the Door

- 2.1. Mark the top fixing point on the face of your door at the desired height and horizontal distance from door edge.
- 2.2. In most instances, the horizontal position should align with the centre of the door stile on a panel door or with any lock, turn or escutcheon fitted to the door. (Figure 2)
- 2.3. Using a spirit level, mark the bottom fixing point — noting the CTC measurement. (Figure 3)

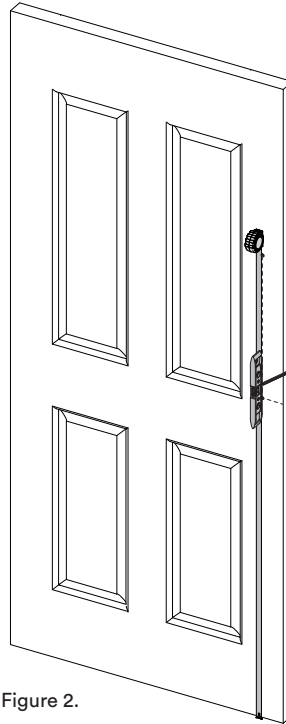

Figure 2.

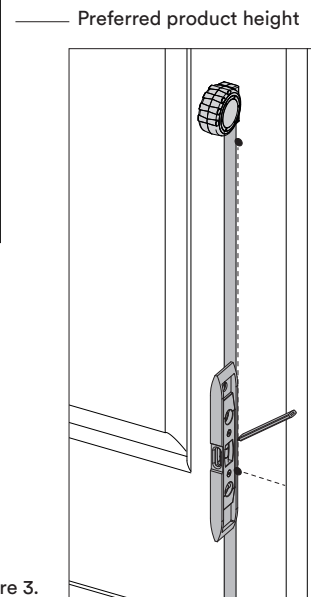

Figure 3.

3. Fitting the Pull Handle (Concealed Fix Method)

- 3.1. Remove the Taylor spindles from the pull handle by loosening the grub screws. (Figure 4)

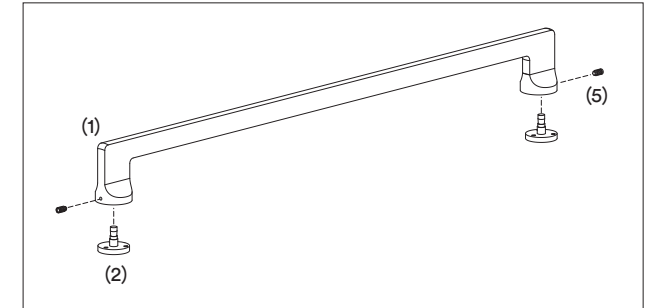

Figure 4.

- 3.2. Centre one of the Taylor spindles on the top fixing hole and using a pencil, mark the three wood screw holes. Repeat for the bottom fixing point.
- 3.3. Drill 2mm pilot holes for the wood screws at each of the six marks and affix the Taylor spindles to the door with wood screws provided. (Figure 3)
- 3.4. Place pull handle on Taylor spindles and tighten both grub screws to secure.

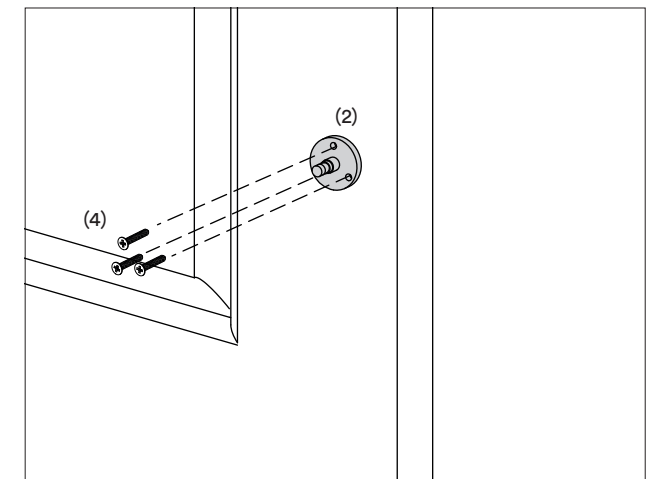

Figure 5.

4. Fitting the Pull Handle (Rear Fix Method)

- 4.1. Drill holes through door at the fixing points marked in step 2.1.
- 4.2. It is important to drill halfway through the door from one door face and complete the hole from the other side to prevent splintering.
- 4.3. Insert fixing bolts through the holes from the inside of the door.
- 4.4. With taylor spindles already attached to the pull handle, align the female thread of the taylor spindle to the top fixing bolt and tighten. Repeat for bottom fixing point. (Figure 6)

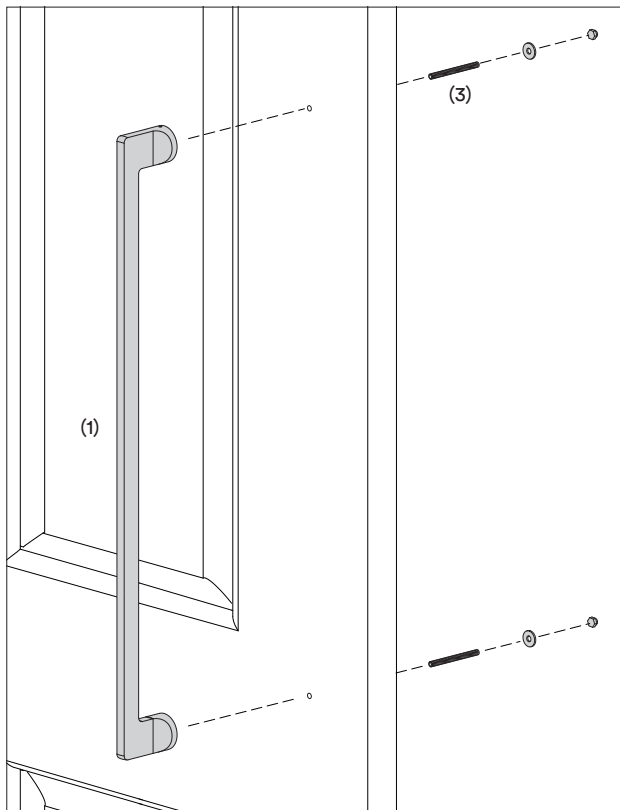

Figure 6.

5. Fitting the Pull Handle (Affixing a Pair)

- 5.1. Drill holes through door at the fixing points marked in step 2.1.
- 5.2. It is important to drill halfway through the door from one door face and complete the hole from the other side to prevent splintering.
- 5.3. Remove taylor spindles on both pull handles by loosening grub screws.
- 5.4. Screw a taylor spindle onto one side of each threaded bolt.
- 5.5. Insert bolt through hole and screw taylor spindle onto opposite end of thread. Hand tighten and ensure taylor spindles are flush against the door faces. (Figure 7)
- 5.6. If required cut threaded bolt to allow taylor spindles to sit flush with door.
- 5.7. To prevent loosening, fix taylor spindles on each side with 2 x woodscrews. Repeat 5.4 – 5.6 at bottom fixing point.
- 5.8. Place pull handles on taylor spindles and tighten all grub screws to secure.

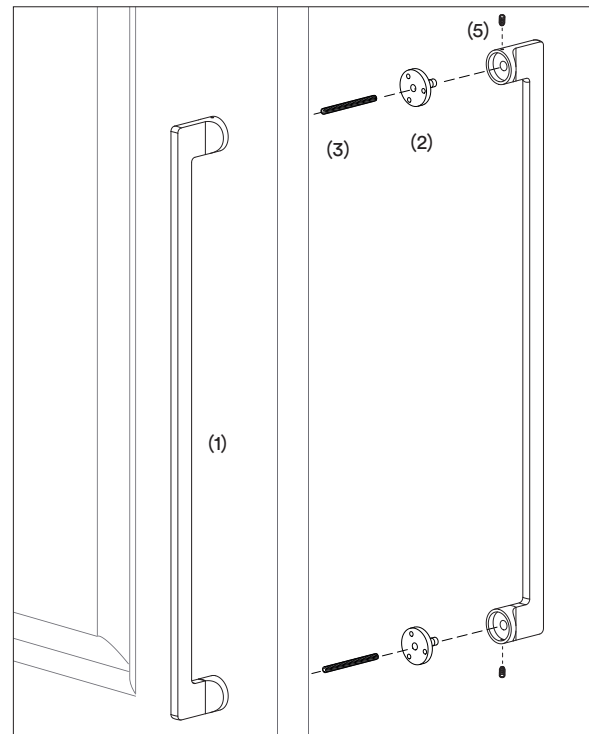
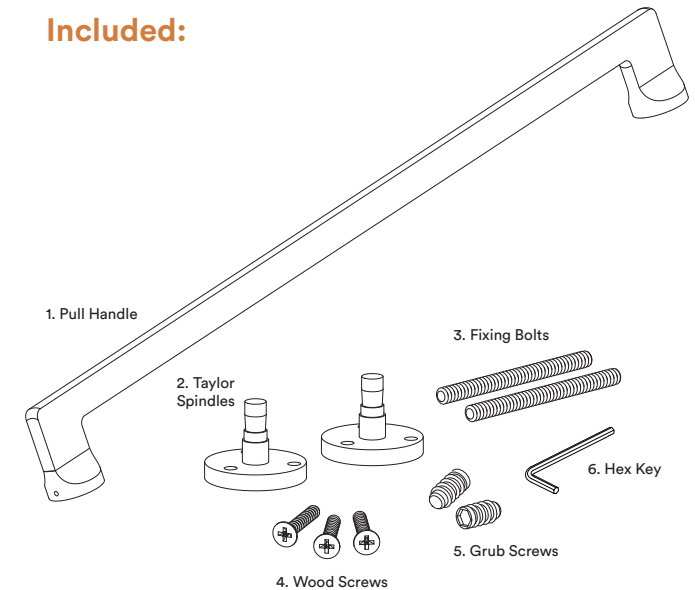
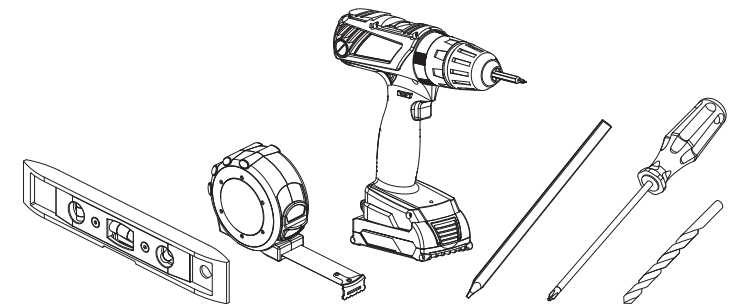

Figure 7.

Included:



Not Included:



PLEASE NOTE:

The screws provided with Iver products are made from solid brass. This allows finishes to be matched as closely as possible and prevents the possibility of screws rusting in coastal areas. Please note that screws require **pre-drilling**.

Please take extra care when fitting.