

























## R Rectangular Plate Door Furniture - Specifications

### FEATURES

Size	165 x 46 x 11.5mm thick.	Material	Manufactured from grade 304 stainless steel for ultimate durability.
Fixing	Concealed External and Visible Internal.	Spindle	7.6mm standard
Standard Finishes	SSS, PSS.		
Door Thickness	32-50mm doors.		

### ORDERING CODES

	R01	Concealed Cylinder
	R02	Visible Cylinder
	R03	Visible Turn Snib
	R03I	Visible Indicator Turn Snib
	R04	Concealed Emergency
	R04I	Concealed Emergency Indicating
	R05	Concealed Plain
	R06	Visible Plain
	R08D	Visible Disabled Turn Snib
	R08H	Visible Hospital Turn Snib
	R09I	Concealed Indicator Turn Snib
	R10DI	Visible Disabled Indicator Turn Snib
	R10HI	Visible Disabled Indicator Turn Snib
	R11	Concealed Cylinder Plate
	R12	Visible Cylinder Plate
	R13	Visible Turn Snib Plate
	R14	Concealed Emergency Plate
	R14I	Concealed Emergency Plate Indicator
	R15	Concealed Plain Plate
	R16	Visible Plain Plate
	R17	Visible Cylinder Plate Offset "D"
	R18	Concealed Double Cylinder Plate
	R18/	Visible Double Cylinder Plate Offset "D"
	R19DI	Concealed Disabled Indicator Turn Snib
	R19HI	Concealed Hospital Indicator Turn Snib

### Finishes

Satin Stainless Steel      SSS

### Door Handing

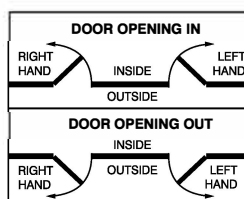

Manufactured to suit Australian Mortice Locks and Latches. Order 8mm spindle to suit European locks.

### Ordering Example

## R0151LHSSS

Finish (SSS, PSS)
*Handing (LH or RH)
Lever Design (50, 51, 52, 54, 55)
Plate Design (R01-R19)



Fire Rated

# NOVAS

## R Rectangular Plate Door Furniture - Lever Options

LEVER 63



LEVER 72



LEVER 65



LEVER 66



# NOVAS

## R Rectangular Plate Door Furniture - Dimensional Drawings

SERIES R PLATE

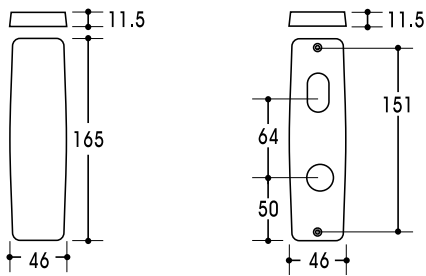

LEVER 66

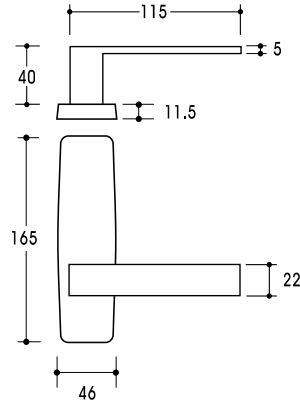

LEVER 63

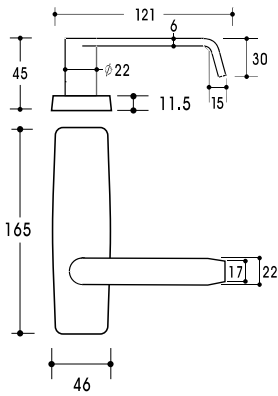

LEVER 72

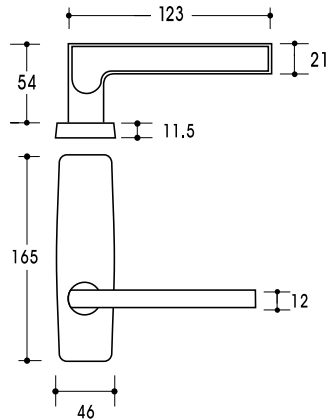

LEVER 65

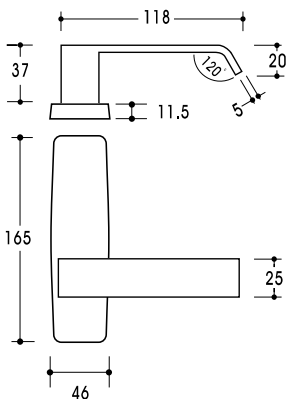

# NOVAS

## R Rectangular Plate Door Furniture - Lever Options

LEVER 50



LEVER 54



LEVER 51



LEVER 55



LEVER 52



# NOVAS

## R Rectangular Plate Door Furniture - Dimensional Drawings

SERIES R PLATE

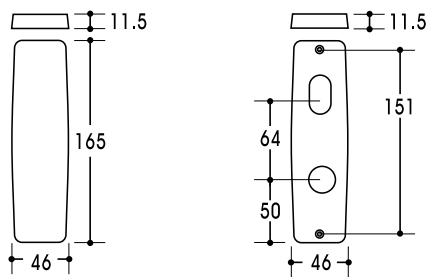

LEVER 52

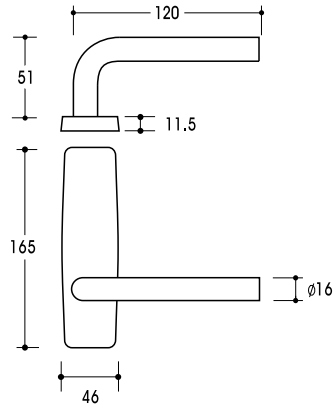

LEVER 50

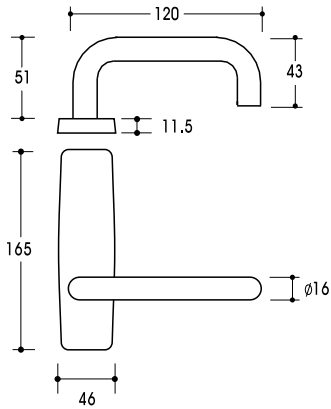

LEVER 54

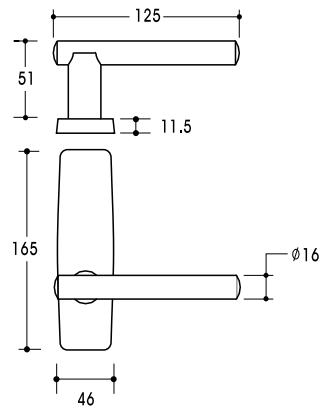

LEVER 51

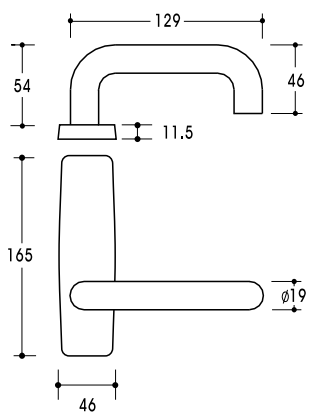

LEVER 55

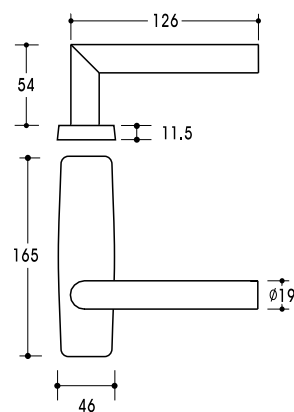

# NOVAS

## Novas Maintenance of Stainless Steel

Retaining the attractive finish of stainless steel is easy with a few simple maintenance steps. When maintained properly, stainless steel will retain its visual appeal and structural integrity in wide range of applications and environments.

Novas Stainless Steel products are designed to be durable, low maintenance, highly resistant to corrosion and easily maintained resulting in a high quality, pleasing appearance.

## Cleaning Stainless Steel

Stainless Steel is best cleaned using a mild detergent and a soft cloth, after washing, rinse in clean, cold water and wipe the surface dry with a soft absorbent cloth. Drying afterwards ensures there no streaky marks on the surface.

## Retaining Surface Integrity

Stainless looks best if its cleaned regularly and correctly which prevents stubborn stains building up. The level of cleaning and maintenance depends primarily on its environment where the product is situated.

### 1.Sea Side

When Stainless Steel is in a coastal environment, tea staining of surface can occur. Tea staining is discolouration of the surface of stainless steel by corrosion. It is a cosmetic issue that does not affect the structural integrity or the lifetime of the material. Discolouration or a tea staining effect most commonly occurs within 5 kilometres of the coast and becomes progressively worse closer to the water. Regular washing also removes deposits (such as salt) that can cause corrosion. In these instances, it is recommended that cleaning is performed fortnightly.

### 2.Interior

Dirt, grease and fingerprints can accumulate from many sources. These can be removed by routine cleaning using a mild detergent and a soft cloth. After washing, rinse in clean, cold water and wipe the surface dry with a soft absorbent cloth. Drying afterwards ensures there are no streaky marks left on the surface. If a mild detergent or dishwashing liquid doesn't shift unsightly stains/finger-marks, then wipe over with glass cleaner on a soft cloth. You can also use a small amount of alcohol, methylated spirits, acetone or mineral turpentine. Then rinse with clean water and dry. You can give longer protection to high traffic areas by lightly rubbing with olive oil or baby oil followed by a polish and shine using a soft cloth.

### 3.Exterior

In most exterior environments normal rain washing is sufficient, but in more polluted or coastal regions the surfaces will require regular washing to retain its pristine condition. (see above in Sea Side for more details) Discolouration or a tea staining effect most commonly occurs within 5 kilometres of the coast and becomes progressively worse closer to the water. For rust or tougher stains apply a cream cleanser with a soft damp cloth, rub gently then rinse with clean cold water. Dry with an absorbent soft cloth.

## Surface Protection

It is important to know that Stainless Steel can be Scratched so it is important to be aware that harsh abrasives, steel wool or plastics sources must NEVER be used. Cloths used to rub over the stainless steel must be free of dirt or chemicals and always avoid vigorous rubbing.

String minerals acids such as hydrochloric, hydrofluoric acid or bleach should never be permitted to encounter stainless steel. If this should happen, the solution must be washed off immediately with plenty of water.

Never use oil based commercial cleaners as the residual oil film can result in an iridescent colour on Stainless Steel.

Environment	Maintenance Schedule
Seafront / Chlorinated Pool	Fortnightly
Coastal (within 5km of coast)	Monthly
Industrial and Urban	Every 3-6 months
Suburban Rural	Annually or as required
Internal	As required to maintain appearance

Please note: Unless regular maintenance of the Stainless Steel surface occurs to the appropriate schedule, the Novas Guarantee will be rendered void.