







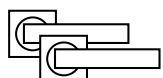
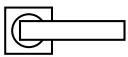

# NOVAS

## F Square Rose Door Furniture - Specifications

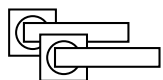
### FEATURES

Size	55mm x 55mm x 10mm thick	Material	Manufactured from grade 304 stainless steel for ultimate durability.
Fixing	Visible 41mm horizontal bolt through	Spindle	7.6mm standard
Standard Finishes	SSS, PSS.		
Door Thickness	32-50mm doors.		

### ORDERING CODES

-  **F01** Complete Set
-  **F02** Half Set
-  **F03** Blank Rose
-  **F04** Privacy Set
-  **F06** Concealed Turn Snib Round
-  **F07** Visible Turn Snib Oval
-  **F08** Cylinder Escutcheon
-  **F09** Emergency Release
-  **F09I** Emergency Release Indicating
-  **F10** Euro Escutcheon

### Finishes

Satin Stainless Steel	SSS
Polished Stainless Steel	PSS

### Door Handing

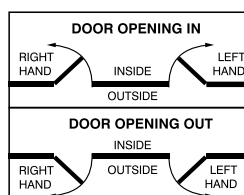

Manufactured to suit Australian mortice locks and latches. Order 8mm spindle to suit European locks.

### Ordering Example

## F0166SSS

Finish (SSS, PSS)

Lever Design (63, 65, 66, 72, 80)

Rose Design (F01-F10)

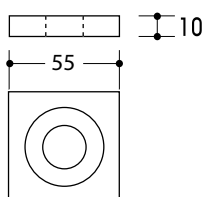

Series F Rose

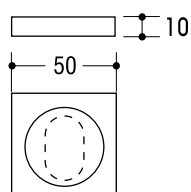

Series F Escutcheons



Fire Rated

# NOVAS

## F Square Rose Door Furniture - Lever Options

LEVER 30



LEVER 35



LEVER 31



LEVER 38



LEVER 32



LEVER 68



# NOVAS

## F Square Rose Door Furniture - Dimensional Drawings

LEVER 30

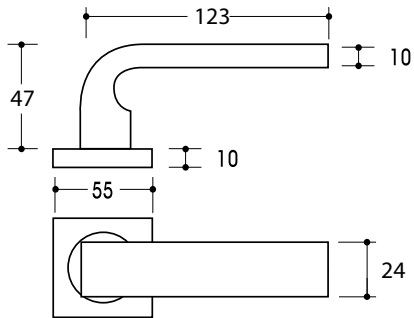

LEVER 35

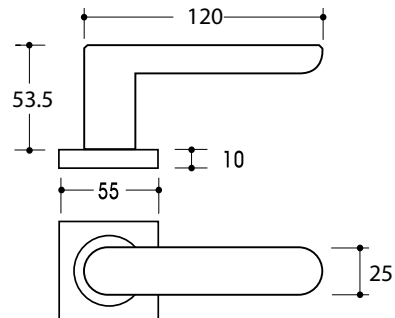

LEVER 31

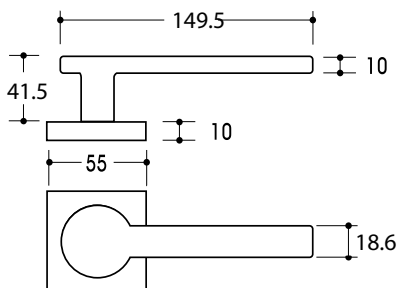

LEVER 38

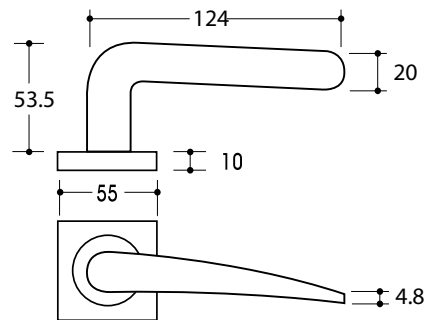

LEVER 32

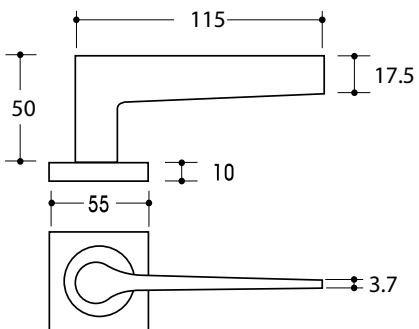

LEVER 68

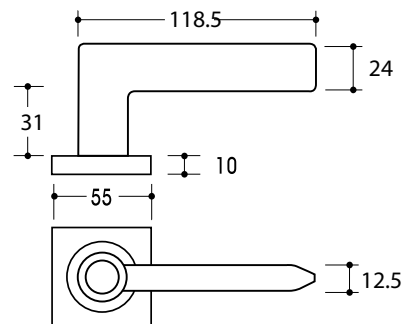

# NOVAS

## F Square Rose Door Furniture - Lever Options

LEVER 63



LEVER 72



LEVER 65



LEVER 66



LEVER 50



LEVER 54



# NOVAS

## F Square Rose Door Furniture - Dimensional Drawings

LEVER 63

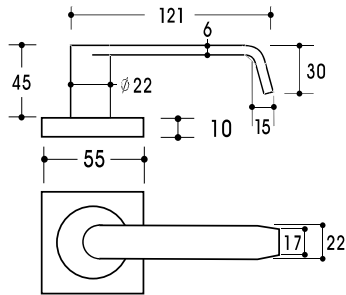

LEVER 72

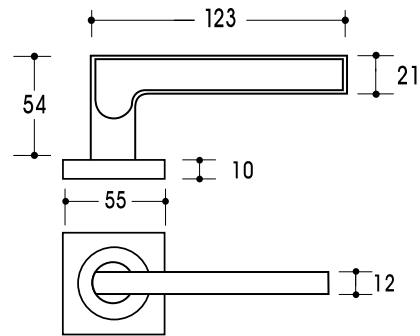

LEVER 65

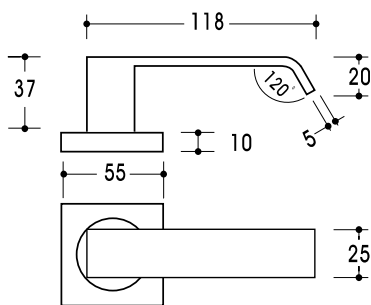

LEVER 66

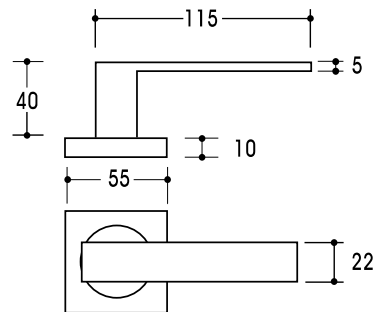

LEVER 50

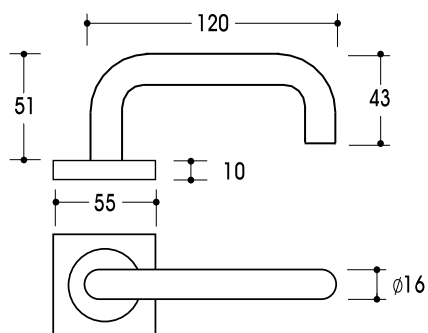

LEVER 54

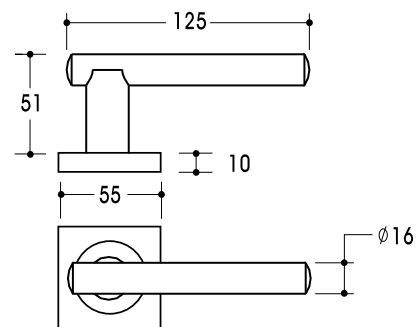

# NOVAS

## F Square Rose Door Furniture - Lever Options

LEVER 51



LEVER 55



## F Square Rose Door Furniture - Dimensional Drawings

LEVER 51

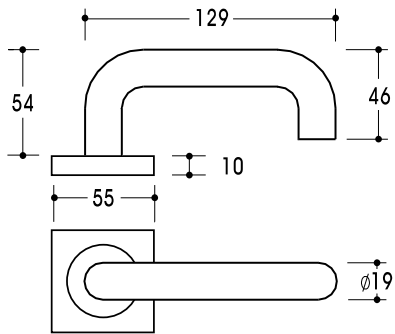

LEVER 55

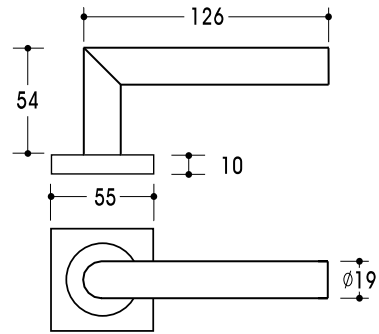

# NOVAS

## Novas Maintenance of Stainless Steel

Retaining the attractive finish of stainless steel is easy with a few simple maintenance steps. When maintained properly, stainless steel will retain its visual appeal and structural integrity in wide range of applications and environments.

Novas Stainless Steel products are designed to be durable, low maintenance, highly resistant to corrosion and easily maintained resulting in a high quality, pleasing appearance.

## Cleaning Stainless Steel

Stainless Steel is best cleaned using a mild detergent and a soft cloth, after washing, rinse in clean, cold water and wipe the surface dry with a soft absorbent cloth. Drying afterwards ensures there no streaky marks on the surface.

## Retaining Surface Integrity

Stainless looks best if its cleaned regularly and correctly which prevents stubborn stains building up. The level of cleaning and maintenance depends primarily on its environment where the product is situated.

### 1.Sea Side

When Stainless Steel is in a coastal environment, tea staining of surface can occur. Tea staining is discolouration of the surface of stainless steel by corrosion. It is a cosmetic issue that does not affect the structural integrity or the lifetime of the material. Discolouration or a tea staining effect most commonly occurs within 5 kilometres of the coast and becomes progressively worse closer to the water. Regular washing also removes deposits (such as salt) that can cause corrosion. In these instances, it is recommended that cleaning is performed fortnightly.

### 2. Interior

Dirt, grease and fingerprints can accumulate from many sources. These can be removed by routine cleaning using a mild detergent and a soft cloth. After washing, rinse in clean, cold water and wipe the surface dry with a soft absorbent cloth. Drying afterwards ensures there are no streaky marks left on the surface. If a mild detergent or dishwashing liquid doesn't shift unsightly stains/finger-marks, then wipe over with glass cleaner on a soft cloth. You can also use a small amount of alcohol, methylated spirits, acetone or mineral turpentine. Then rinse with clean water and dry. You can give longer protection to high traffic areas by lightly rubbing with olive oil or baby oil followed by a polish and shine using a soft cloth.

### 3.Exterior

In most exterior environments normal rain washing is sufficient, but in more polluted or coastal regions the surfaces will require regular washing to retain its pristine condition. (see above in Sea Side for more details) Discolouration or a tea staining effect most commonly occurs within 5 kilometres of the coast and becomes progressively worse closer to the water. For rust or tougher stains apply a cream cleanser with a soft damp cloth, rub gently then rinse with clean cold water. Dry with an absorbent soft cloth.

## Surface Protection

It is important to know that Stainless Steel can be Scratched so it is important to be aware that harsh abrasives, steel wool or plastics sources must NEVER be used. Cloths used to rub over the stainless steel must be free of gift or chemicals and always avoid vigorous rubbing.

String minerals acids such as hydrochloric, hydrofluoric acid or bleach should never be permitted to encounter stainless steel. If this should happen, the solution must be washed off immediately with plenty of water.

Never use oil based commercial cleaners as the residual oil film can result in an iridescent colour on Stainless Steel.

Environment	Maintenance Schedule
Seafront / Chlorinated Pool	Fortnightly
Coastal (within 5km of coast)	Monthly
Industrial and Urban	Every 3-6 months
Suburban Rural	Annually or as required
Internal	As required to maintain appearance

Please note: Unless regular maintenance of the Stainless Steel surface occurs to the appropriate schedule, the Novas Guarantee will be rendered void.