

RP70



A heavy duty, fully morticed, automatic door bottom seal that is spring loaded to lift clear of the floor when the door is opened. It is self levelling and reversible for left and right handed operation. Acoustically designed, featuring an EPDM foam gasket for acoustic door applications. RP70 is operated automatically by pressure against the door jamb on its adjustable brass strike.

Location: Fully morticed into the bottom of single and double butt hinged doors (minimum door thickness of 45mm). For double doors, plain meeting stiles are required.

Min/Max Gap: 3mm to 13mm.

Finish: Satin clear (silver) anodised aluminium (15µm).

Fixing: Screw fix. Colour matched escutcheon plates and zinc plated, cross recess head S.T. screws supplied.

Seal: RP338. Black EPDM sponge (SE).

Sizes: 1500mm, 1220mm, 1070mm, 920mm, 610mm, 450mm to 300mm(min). Seals cut back to exact size.

Approvals

Acoustic AUS/NZ: NCC Spec. F5.5.
UK/EU: Approved Document E. Rated to BS EN ISO 717.1.

Fire AUS/NZ: NCC Spec. C3.4.
AS1530.4 & AS/NZS 1905.1.

UK/EU: Approved Document B.
BS 476 Pt. 20 & 22 (similar to BS EN 1634-1).

FRL & FRR-/240/30 and FD240. 🔥

Energy NCC Pt. 3.12.3.3 & J3.4.

Design for Access and Mobility

High efficiency mechanism to assist with the closing force requirements detailed in AS1428.1.

Durability Tested to over 1,000,000 operating cycles without failure.

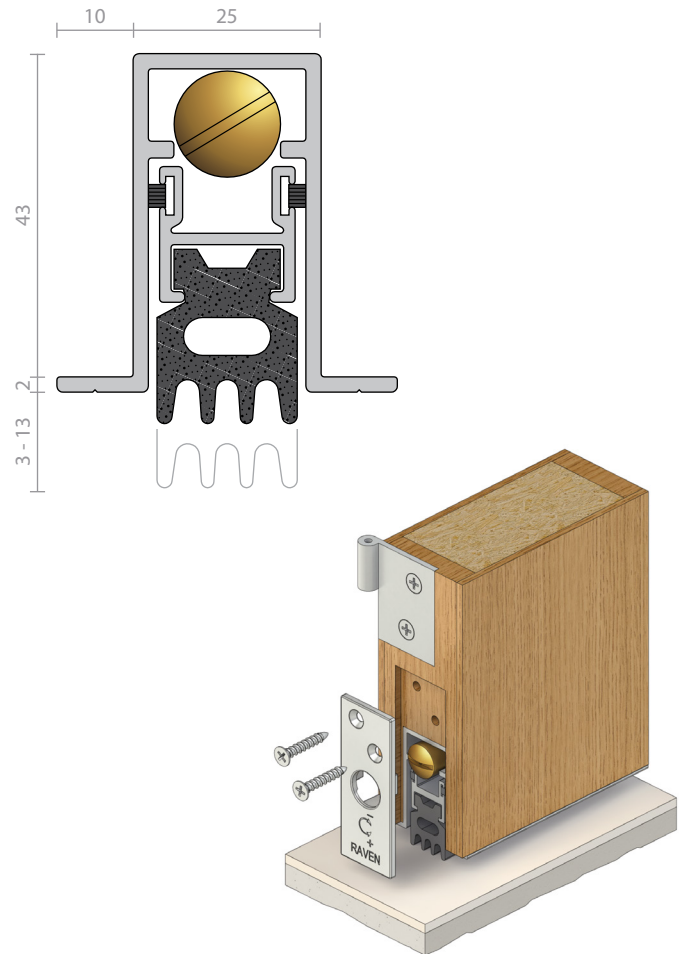

RP70Si



A heavy duty, fully morticed, automatic door bottom seal that is spring loaded to lift clear of the floor when the door is opened. It is self levelling and reversible for left and right handed operation. Acoustically designed, featuring a silicon gasket for smoke and fire door applications. RP70Si is operated automatically by pressure against the door jamb on its adjustable brass strike.

Location: Fully morticed into the bottom of single and double butt hinged doors (minimum door thickness of 45mm). For double doors, plain meeting stiles are required.

Min/Max Gap: 3mm to 13mm.

Finish: Satin clear (silver) anodised aluminium (15µm).

Fixing: Screw fix. Colour matched escutcheon plates and zinc plated, cross recess head S.T. screws supplied.

Seal: RP338Si. Grey silicon rubber (SE).

Sizes: 1500mm, 1220mm, 1070mm, 920mm, 610mm, 450mm to 300mm(min). Seals cut back to exact size.

Approvals

UL Cert. GVVY.R37913

Fire AUS/NZ: NCC Spec. C3.4.
AS1530.4 & AS/NZS 1905.1. NZ BC Compliance Doc. App. C6.1.1.

UK/EU: Approved Document B.
BS 476 Pt. 20 & 22 (similar to BS EN 1634-1).

FRL & FRR-/240/30 and FD240. 🔥
Gasket flammability index 1 when tested to AS1530.2.

Smoke NCC Spec. C3.4. AS1530.7 & BS EN 1634-3. Meets smoke leakage rates specified in AS6905 & EN 13501-2 "Sa", "Sm".

Energy NCC Pt. 3.12.3.3 & J3.4.

Design for Access and Mobility

High efficiency mechanism to assist with the closing force requirements detailed in AS1428.1.

Durability Tested to over 1,000,000 operating cycles without failure.

