

# Sylvan SLIDING DOOR PULL/LOCK INSTALLATION INSTRUCTIONS

## Model Number SDPPS and SDPBK

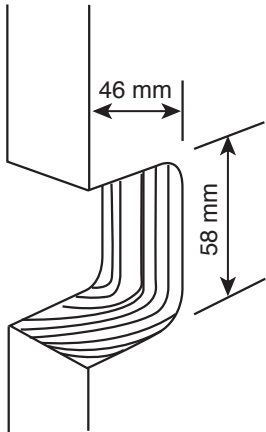

1. Decide on height of sliding pull handle on door. Using Template cut out detail in door.

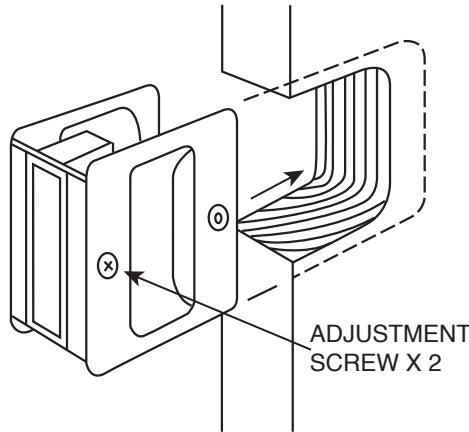

2. Position pull into the door by loosening door thickness adjustment screws.

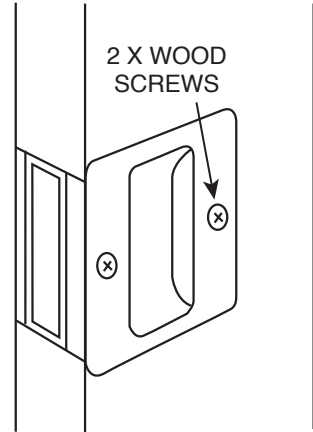

3. Fit sliding pull handle by tightening adjustment screws ensuring pull is central in the door. Fit the larger style wood screws as shown.

## Striker Plate Model Number SDPBK only

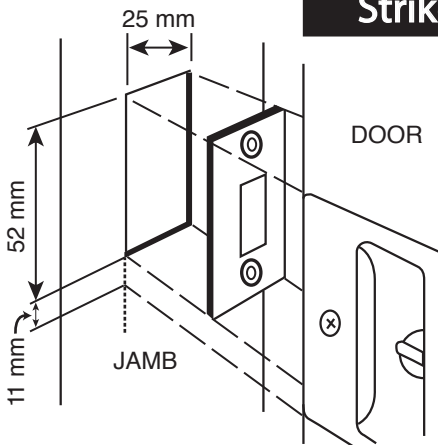

4. By closing the door, line up striker plate position on jamb, central to the lock. Mark and chisel out mortice for striker into the jamb.

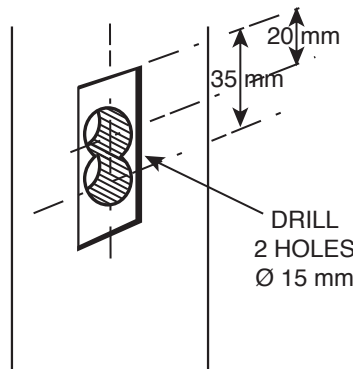

5. Drill two 15 mm (9/16") diameter holes, 12 mm deep at 20 mm from top of plate to centre of hole and also 35 mm from the top of the plate to the centre of the hole. Chisel out holes to form a rectangular hole for clearance of locking arm.

6. Fix striker plate into jamb with the two smaller wood screws provided.

### TEMPLATE

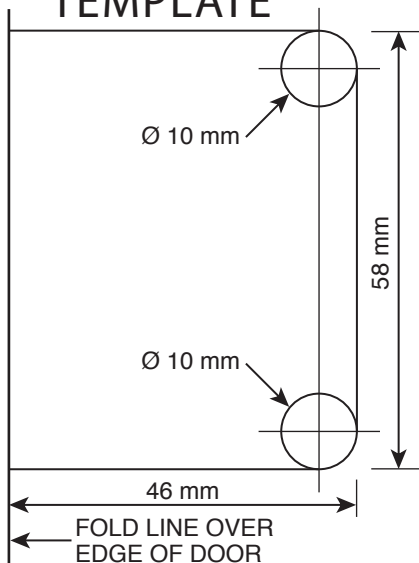

## To change handing reverse outer plates (privacy lock only SDPBK)

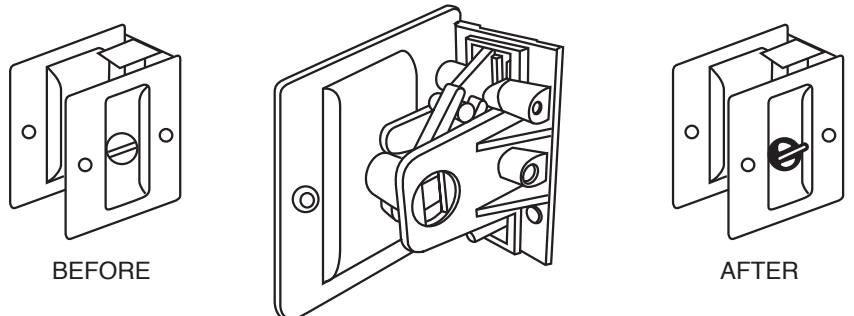

Remove screws, swap plates around, and ensure drive unit is engaged into both slots.

**Specifications subject to change without notice.**