



Synergy Series Mortice Locks Service Manual



ASSA ABLOY

ASSA ABLOY, the global leader
in door opening solutions

Introduction



Service Manual:

This manual contains a complete listing of parts and assemblies for the Synergy Series Cylinder Mortise Locks manufactured by ASSA ABLOY Australia. Exploded views are included along with parts list for ordering of replacement components.

ASSA ABLOY Australia reserves the right to make changes in design or specifications, or to make additions or improvements to their product without incurring any obligation to incorporate these amendments in product previously manufactured.

ASSA ABLOY Australia are not responsible for additions or alterations made to their product by others.

Maintenance:

Cleaning: Care should be taken during construction/ refurbishment to ensure that paint, thinners, mortar or cement splashes are carefully removed from locks, furniture and hardware. Removal of these splashes with strong cleaning agents or scourers should be avoided.

Dirt and grime should be regularly removed with a soft damp cloth. A solution of mild soap and water may be required. During cleaning, care should be taken to prevent cleaning solution from entering the cylinder keyway. Surfaces should be dried and possibly lubricated.

Lubrication: During assembly of the lock, the areas of contact of the internal mechanism which require lubrication are given an application of high quality grease. As such further lubrication should not be necessary.

However, where locks are subjected to heavy traffic, the external contact areas of the bolt and strike may require an occasional smear of light machine oil.

Contents

3570 Series Function Matrix	6
3580 Series Function Matrix	7
5900 Series Kit Conversion	7
4800/5800 Series Backset Suitability Chart	8
3570 Series Nightlatches	10
3571 Series Deadlocks	11
3572/3574 Series Multi-Function Lock	12
3572/3574 Multi-Function Lock Functions	13
3573 Series Sliding Door Deadlocks	14
3577 Series Dual Entry Lock	16
3578 Series Holdback Lock	17
3579 Series SCEC Secure Area Mortice Locks	18
3572AF Series Multi-Functions Locks - Aluminium Fix Lock	19
4570 Series 89mm Extended Backset Mortice Locks	20
5570 Series 127mm Extended Backset Mortice Locks	21
3582/3584 Series Multi-Function Short Backset Locks	23
3582 Series Lock Functions	24
3592/3594 Series Multi-function Short Backset Locks	25
4580/5580/6580 Series Extended Short Backset Locks	26
Cylinders	27
Accessories	30
Adaptors	32

3572 Series Mortice Lock - Mounting Instructions	34
3570 Series Mortice Lock - Mounting Instructions	36
3570AF Series Mortice Lock - Installation Instructions	37
3570 Series Mortice Lock - Installation Instructions	38
3571/3573 Mortice Lock - Mounting Instructions	39
3577 Series Dual Entry Mortice Lock - Mounting Instructions	42
3578 Series Mortice Lock - Mounting Instructions	44
3579 Series Mortice Lock - Mounting Instructions	47
3570 Series Rebate Mortice Locks - Mounting Instructions	50
3580 Short Backset Mortice Lock - Mounting Instructions	51
3590 Series Mortice Locks - Mounting Instructions	53
3580 Series Rebate Mortice Locks - Mounting Instructions	56



3570 Series Function Matrix

Synergy Series	Function Description	Primary Lock	Cylinder(s)	Turn Adaptor	Outside Cylinder Cam	Inside Cylinder Cam
3570SC	<i>Nightlatch Primary Lock</i>	3570SC	-	-		
3570-T#SC	Nightlatch - turn only	3570SC	-	SP3570-5050		
3570X-#SC	Nightlatch - single cyl	3570SC	570-2SC	-	X	
3570XT#SC	Nightlatch - cyl & turn	3570SC	570-2SC	SP3570-5050	X	
3570XX#SC	Nightlatch - double cyl	3570SC	570-701SC	-	X	X
3571SC	<i>Deadlock Primary Lock</i>	3571SC	-	-		
3571DE#SC	Escape Deadlock	3571DE#SCNCYL	571-2SC	(SP3571-6150)*	Y	
3571-T#SC	Exit Door Deadlock	3571SC	-	SP3571-5050		
3571PT	Privacy Deadlock (Through Fix)	3571PTSC	-	(SP3571-5050)*		
3571WT#SC	Cylinder and Turn Deadlock	3571SC	571-2SC	SP3571-5050	Y	
3571Y-#SC	Single Cylinder Deadlock	3571SC	571-2SC	-	Y	
3571YY#SC	Double Cylinder Deadlock	3571SC	571-701SC	-	Y	Y
3572SC	<i>Multi-function Primary Lock</i>	3572SC	-	-		
3572#SC	Exit Door Latch	3572SC	-	-		
3572EA#SC	Escape Privacy Latch - Anti-lockout	3572SC	-	SP3572-5250		
3572M-#SC	Anti-Vandal Latch	3572SC	575-52SC	SP3572-5350 (RH), SP3572-5450 (LH)	M	
3572-T#SC	Exit Door Lock - turn only	3572SC	-	SP3572-5250		
3572WA#SC	Escape Office Lock - Anti-lockout	3572SC	575-2SC	SP3572-5250	W	
3572WT#SC	Escape Office Lock	3572SC	575-2SC	SP3572-5250	W	
3572X-#SC	Storeroom Lock	3572SC	570-2SC	-	X	
3572XA#SC	Entry Door Lock - Anti-vandal	3572XA#SCNCYL	570-302LHSC, 570-302RHSC	(SP3572-5250)*	XAL/XAR	
3572XT#SC	Entry Door Lock	3572SC	570-2SC	SP3572-5250	X	
3572XZ#SC	Double Cylinder Escape Lock	3572SC	574-701SC	-	X	Z
3572-Z#SC	Single Cylinder Exit Door Lock	3572SC	572-2SC	-		Z
3572Z-#SC	Classroom Lock	3572SC	572-2SC	-	Z	
3573SC	<i>Sliding Door Deadlock Primary Lock</i>	3573SC	-	-		
3573DE#SC	Sliding Door Escape Deadlock	3573DE#SCNCYL	571-2SC	(SP3571-6150)*	Y	
3573PT#SC	Sliding Door Privacy Lock (Through Fix)	3573PTSC	-	(SP3571-5050)*		
3573-TSC	Sliding Exit Door Deadlock	3573SC	-	SP3571-5050		
3573WTSC	Sliding Door Cylinder and Turn Deadlock	3573SC	575-2SC	SP3571-5050	W	
3573Y-#SC	Single Cylinder Sliding Door Deadlock	3573SC	571-2SC	-	Y	
3573YY#SC	Double Cylinder Sliding Door Deadlock	3573SC	571-701SC	-	Y	Y
3574SC	<i>Passage Latch</i>	3574SC	-	-		
3574#SC	Passage Latch	3574SC	-	-		
3574ET#SC	Privacy Latch	3572SC	-	SP3572-5250		
3574WT#SC	Office Lock	3572SC	575-2SC	SP3572-5250	W	
3574XX#SC	Double Cylinder Override Lock	3572SC	570-701SC	-	X	X
3574XZ#SC	Glass Entry Door Lock	3572SC	574-701SC	-	X	Z
3574-Z#SC	Single Cylinder Glass Door Lock	3572SC	572-2SC	-		Z
3574Z-#SC	Single Cylinder Glass Entry Door Lock	3572SC	572-2SC	-	Z	
3574ZZ#SC	Double Cylinder Glass Door Lock	3572SC	572-701SC	-	Z	Z
3577SC	<i>Dual Entry Primary Lock</i>	3577SC~	-	-		
3577EA#SC	Key Entry Privacy Lock	3577SC~	3P77/101SC	SP3572-5250		
3577M#	Dual Entry Lock - Key Lockout	3577SC~	575-52SC and 577-2SC	SP3572-5350 (RH), SP3572-5450 (LH)	M	
3577X#	Dual Entry Lock	3577SC~	570-2SC and 577-2SC	-	X	
3577Z#	Dual Entry Lock - Key Lockout	3577SC~	572-2SC and 577-2SC	-	Z	
3578SC	<i>Holdback Primary Lock</i>	3578SC	-	-		
3578M-#SC	Anti-Vandal Latch - Holdback	3578SC	575-52SC	SP3572-5350 (RH), SP3572-5450 (LH)	M	
3578WT#SC	Escape Office Lock - Holdback	3578SC	575-2SC	SP3572-5250	W	
3578Z-#SC	Classroom Lock - Holdback	3578SC	572-2SC	-	Z	
3578XZ#SC	Double Cylinder Lock - Holdback	3578SC	574-701SC	-	X	Z

Items in Italics are Primary locks and can be purchased from ASSA ABLOY

#= Left (L) or Right (R) handing

*= Included with Primary Lock

^= Cam only, included with Primary lock

~= Can be ordered as 3572SC and SP3577-5619. Cylinders must be ordered separately.

3580 Series Function Matrix

Synergy Series	Function Description	Primary Lock	Cylinder(s)	Turn Adaptor	Outside Cylinder Cam	Inside Cylinder Cam
3582SC	<i>Short Backset Primary Lock - Metal Fixing</i>	3582SC				
3582-ASC	<i>Short Backset Anti-lock Primary Lock</i>	3582-ASC				
3582-T#SC	Exit Door Lock - turn only	3582SC		SP3572-5250		
3582WA#SC	Escape Office Lock - Anti-lockout	3582-ASC	575-2SC	SP3572-5250	W	
3582WT#SC	Escape Office Lock	3582SC	575-2SC	SP3572-5250	W	
3582X-#SC	Storeroom Lock	3582SC	570-2SC		X	
3582XT#SC	Entry Door Lock	3582SC	570-2SC	SP3572-5250	X	
3582XZ#SC	Double Cylinder Escape Lock	3582SC	574-701SC		X	Z
3582-Z#SC	Single Cylinder Exit Door Lock	3582SC	572-2SC			Z
3582Z-#SC	Classroom Lock	3582SC	572-2SC		Z	
3584ET#SC	Privacy Latch	3582SC		SP3572-5250		
3584SC	Passage Latch	3582SC				
3584-T#SC	Patio Lock - turn only	3582SC		SP3572-5250		
3584WT#SC	Office Lock	3582SC	575-2SC	SP3572-5250	W	
3584XX#SC	Double Cylinder Glass Door Lock	3582SC	570-701SC		X	X
3584XZ#SC	Glass Entry Door Lock	3582SC	574-701SC		X	Z
3584Z-#SC	Single Cylinder Glass Entry Door Lock	3582SC	572-2SC		Z	
3584ZZ#SC	Double Cylinder Glass Door Lock	3582SC	572-701SC		Z	Z
3592SC	<i>Short Backset Primary Lock - Timber Fixing</i>	3592SC				

Items in Italics are Primary locks and can be purchased from ASSA ABLOY
 # = Left (L) or Right (R) handing

5900 Series Kit Conversions

Old 5900 Series Kits

The kits listed below now need to be ordered as individual parts.

3580 Series Part Number	5900 Series Part number	Kit Description	Parts now required	Product Description
3582-1	5900-1	Exterior Deadlatch	3582SC	23mm Primary Lock
			SP3540-T1SC	Escape Turn
			SP3540-CESC	Cylinder Escutcheon
			SP3580-2402SC	3582 Holdback Cylinder RH
			or SP3580-2452SC	3582 Holdback Cylinder LH
3582-3	5900-3	Exterior and Exit Door Lock	3582SC	23mm Primary Lock
			2 x SP3540-CESC	Cylinder Escutcheon
			570-2SC	570 Cylinder with X cam
			SP3580-2402SC	3582 Holdback Cylinder RH
			or SP3580-2452SC	3582 Holdback Cylinder LH
3582-5	5900-505	Single Action Escape Latch	3582SC	23mm Primary Lock
			4800SC	External Plate with Cylinder hole
			4905/70SC	Lever on Internal Plain Plate
			SP3580-2402SC	3582 Holdback Cylinder RH
			or SP3580-2452SC	3582 Holdback Cylinder LH

4800/5800 Series Brass Door Furniture Backset Suitability Chart

Based on 12mm doorstop

Lever Number	Handed	3580 23mm	4580 25.4mm	5580 30mm	6580 38mm
32	No	No	No	Yes	Yes
41	Yes	No	No	Yes	Yes
44	No	No	No	No	No
45	No	No	No	Yes	Yes
50	Yes	No	No	No	No
53	Yes	No	No	Yes	Yes
55A	No	No	No	Yes	Yes
59	No	No	No	Yes	Yes
62	No	No	No	Yes	Yes
70	No	Yes	Yes	Yes	Yes
71	No	No	No	Yes	Yes
74	No	No	No	Yes	Yes
78	No	No	No	Yes	Yes
79	No	No	No	No	No
79B	No	No	No	Yes	Yes
80	No	No	Yes	Yes	Yes
83	No	No	No	Yes	Yes
90	No	No	No	Yes	Yes
91	No	No	No	Yes	Yes
94	Yes	Yes	Yes	Yes	Yes
97	No	Yes	Yes	Yes	Yes





ASSA ABLOY



Synergy 3570 Series

3570 Series Nightlatches

Various latching functions operated by a key outside and by a turnknob or key inside. The Nightlatch locks automatically when the door is closed.

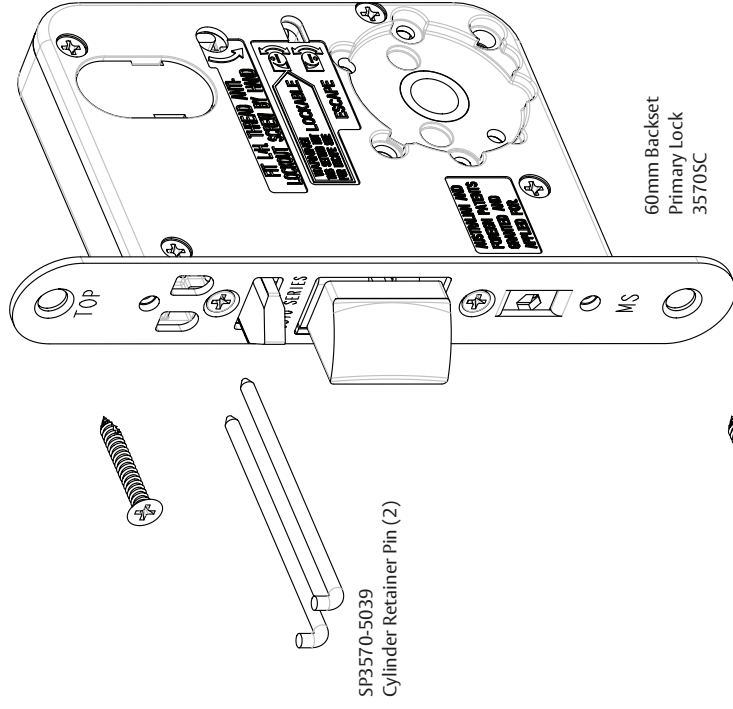

SP3570-5036SSS
SP3570-5136CP/PB
Face Plate

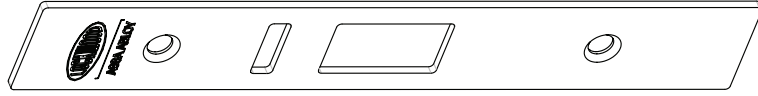

SP570-130ZP
SP570-130PB
Mounting Screw (2)

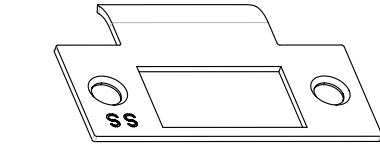

SP3570-5153CP/PB
SP3570-5053SSS
Strike

SP3570-5333CP/PB
SP3570-5332SSS
Mounting Plate Screws (2)

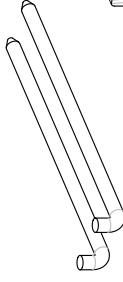

SP3570-5039
Cylinder Retainer Pin (2)



SP570-130ZP
Mounting Screw (2)

3570 Series Nightlatch Lock Functions

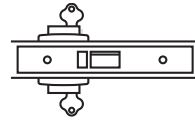

Communicating Door Latch
3570XX

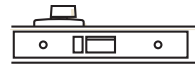

Exit Door Latch
3570-T

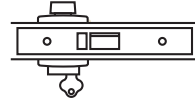

Nightlatch
3570XT

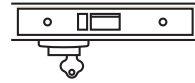

Cylinder Latch
3570X

3570 Series Nightlatch

Orderable Locks

3570SC* Nightlatch Primary Lock

3570TSC Nightlatch Primary Lock with Nightlatch Turn Adaptor

3570AFSC Nightlatch Primary Lock Aluminium Fix

*Also available in Chrome Plate and Polished Brass finishes

3571 Series Deadlocks

These locks have various deadlocking functions which can be operated by key outside and by turnknob or key inside.

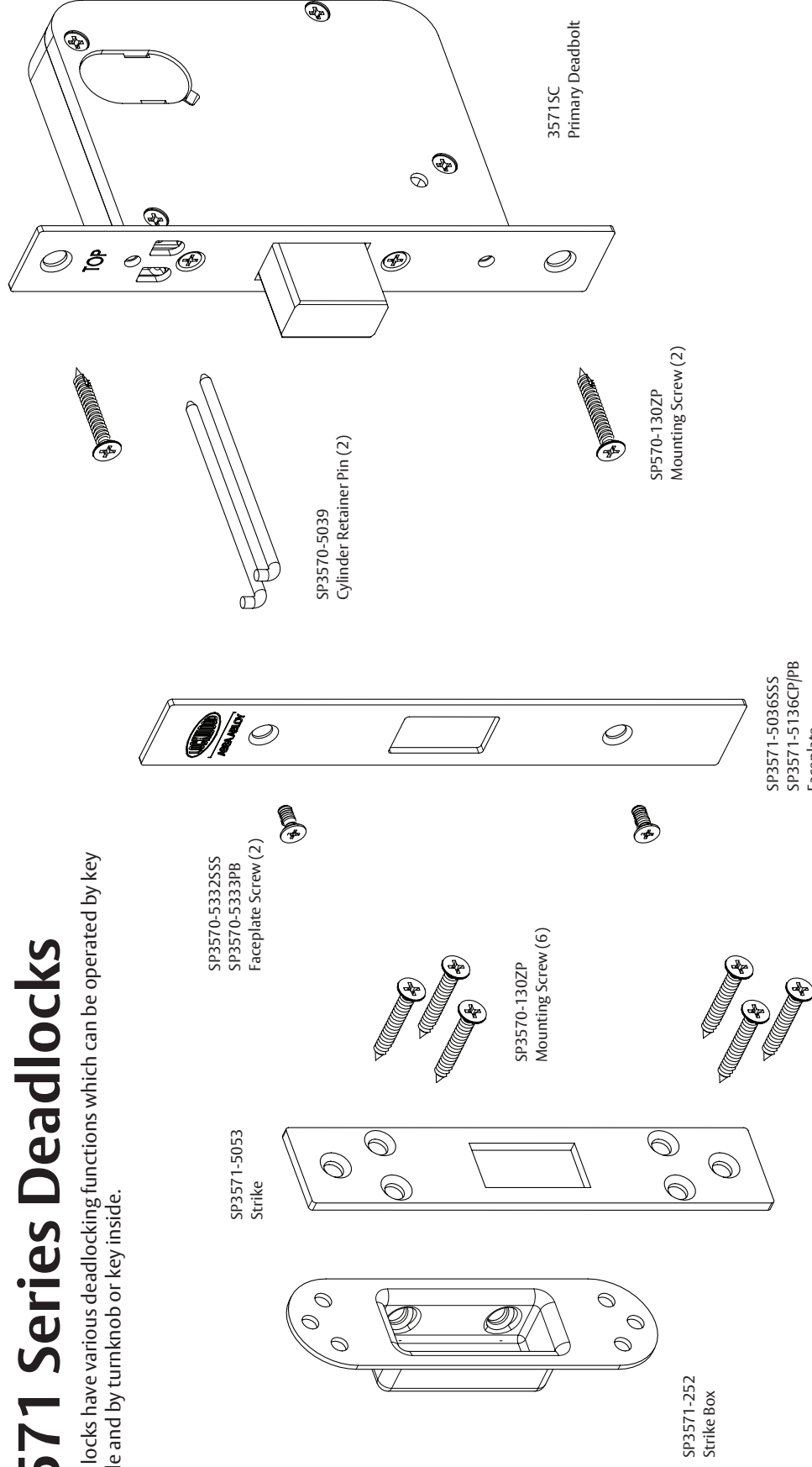

3571 Series Deadlock

Orderable Locks

3571SC*	Deadlock Primary Lock
3571TSC	Deadlock Primary Lock with Deadlock Turn Adaptor
3571AFSC	Deadlock Primary Lock Aluminium Fix
3571DELSNCYL	Escape Deadlock, LH Escape Turn and Adaptor
3571DERSNCYL	Escape Deadlock, RH Escape Turn and Adaptor
3571PTSC	Through Fix Privacy Deadbolt with Deadlock Turn Adaptor

3571 Series Deadlock Functions

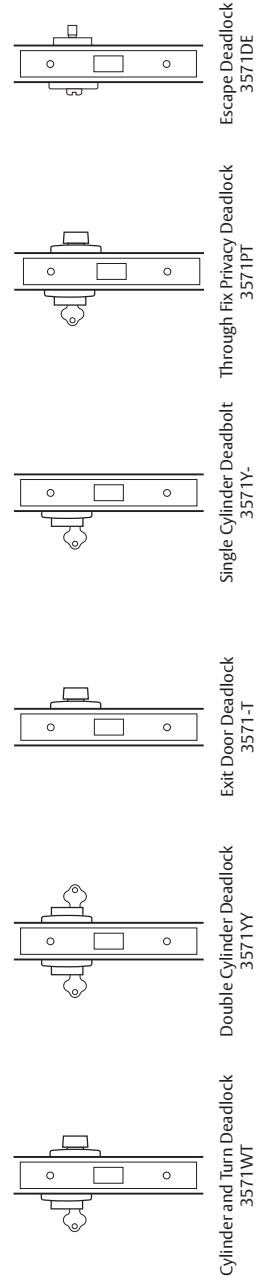

*Also available in Chrome Plate and Polished Brass finishes

3572/3574 Series Multi-Function Lock

These locks have various latching functions which can be operated by key or handle outside and by turnknob key or handle inside.

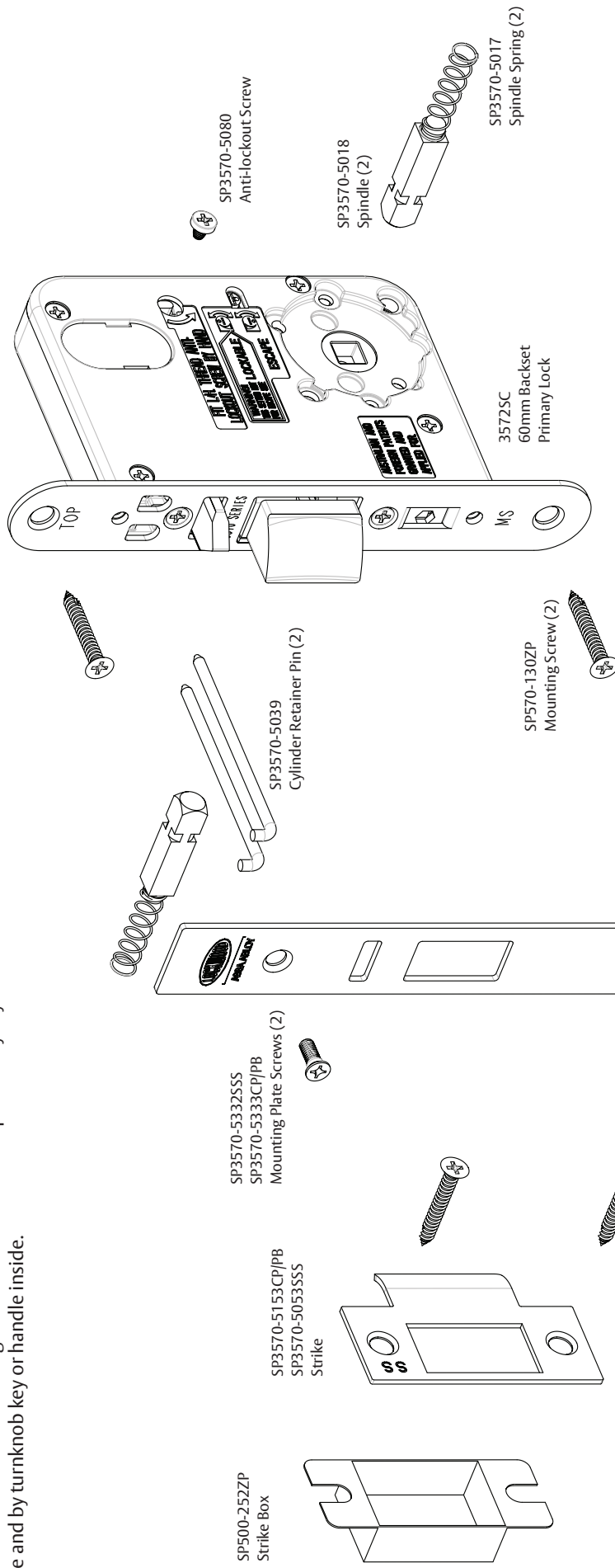

3572 Series Multi-Function Primary Lock

Orderable Locks

3572SC*	Multi-Function Primary Lock
3572AFSC	Multi-Function Primary Lock Aluminium Fix
3572MAGSC	Multi-Function Primary Lock with Faceplate to suit ES2100
3572SCM8	Multi-Function Primary Lock 8mm Furniture Hubs and Modric Spring
3572SCNOHD	Multi-Function Primary Lock no Hub Disc (Suits Aperto Esc)
3572XALSCNCYL	Anti-Vandal Anti-Lockout Lock Case and Adaptor Left Hand
3572XARSCNCYL	Anti-Vandal Anti-Lockout Lock Case and Adaptor Right Hand
3572TSC	Multi-Function Primary Lock with Turn Adaptor
3572M-LSC	Anti-Vandal Classroom Lock with M Cylinder Left Hand
3572M-RSC	Anti-Vandal Classroom Lock with M Cylinder Right Hand
3572XSC	Storeroom Lock - Primary Lock with X Cylinder
3572ZSC	Classroom Lock - Primary Lock with Z Cylinder
3572WASC	Anti-Lockout Lock - Primary Lock with W Cylinder and Turn Adaptor
3572XTSC	Entry Lock - Primary Lock with X Cylinder and Turn Adaptor
3574SC*	Passage Latch, Plainlatch only
3574AFSC	Passage Latch Aluminium Fix

*Also available in Chrome Plate and Polished Brass finishes

3572/3574 Multi-Function Lock Functions

Escape Function Locks

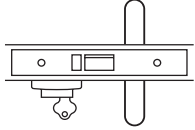

Storeroom Lock
3572X

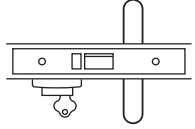

Classroom Lock
3572Z

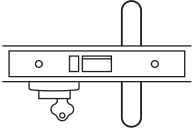

Anti-Vandal Classroom Lock
3572M

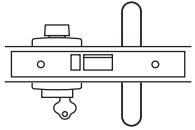

Entry Lock
3572XT

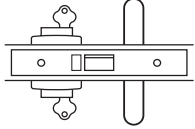

Double Cylinder Escape Lock
3572XZ

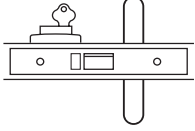

Single Cylinder Exit Lock
3572-Z

Escape Function Locks (continued)

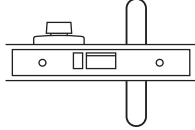

Exit Lock
3572-T

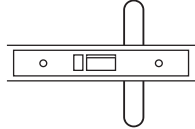

Glass Door Lock
3574Z

Combination Function Locks (continued)

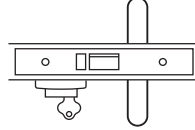

Glass Door Lock
3574Z

Combination Function Locks

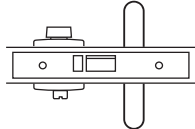

Privacy Lock
3574ET

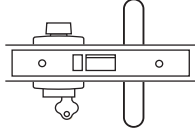

Office Lock
3574WT

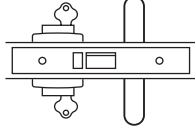

Glass Door Entry Lock
3574XZ

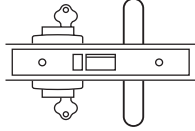

Double Cylinder Glass Door Lock
3574ZZ

Anti - Lockout & Escape Function Locks

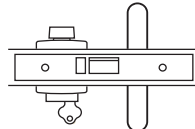

Anti-lockout Escape Lock
3572WA

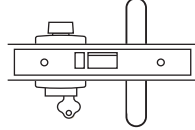

Anti-Vandal Door Lock
3572XA

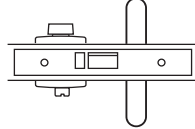

Anti-lockout Privacy Escape Lock
3572EA

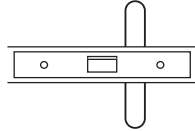

Passage Latch
3574-

3573 Series Sliding Door Deadlocks

These locks have various deadlocking functions which can be operated by key outside and by turnknob or key inside.

SP3571-5036SSS
SP3571-5136CP/PB
Faceplate

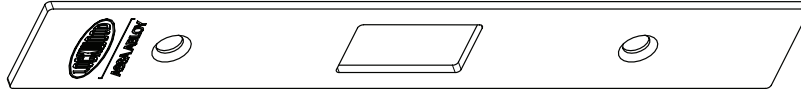

SP570-130ZP
Mounting Screw (6)

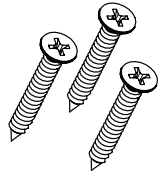

SP3570-5332SSS
SP3570-5333PB
Faceplate Screw (2)

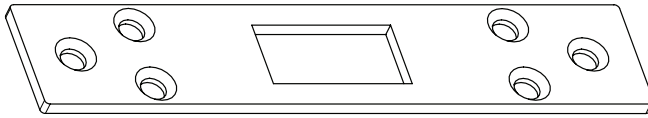

SP3571-5053
Strike

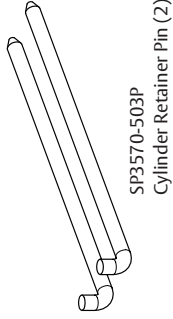

SP570-503P
Cylinder Retainer Pin (2)



SP570-130ZP
Mounting Screw (2)

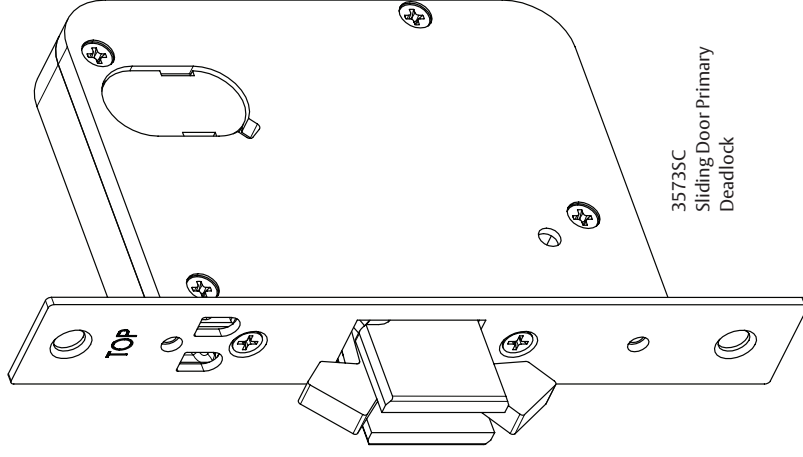

3573SC
Sliding Door Primary
Deadlock

3573 Series Sliding Door Deadlocks

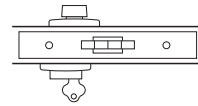

Sliding Door Cylinder
and Turn Adaptor
3573WT

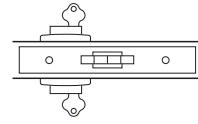

Sliding Door Double
Cylinder Deadlock
3573Y

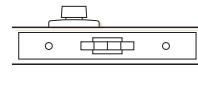

Exit Sliding
Door Deadbolt
3573-T

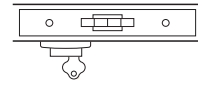

Single Cylinder Sliding
Door Deadlock
3573Y

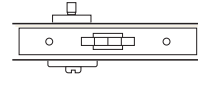

Sliding Door Through
Fix Privacy Deadlock
3573PT

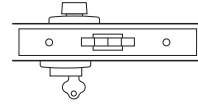

Sliding Door
Escape Deadlock
3573DE

3573 Series Sliding Door Deadlock

Orderable Locks

3573SC*	Sliding Door Deadlock Primary Lock
3573-TSC	Sliding Door Deadlock Primary Lock with Deadlock Turn Adaptor
3573AFSC	Sliding Door Deadlock Primary Lock with Aluminium Fixing Tabs
3573DELSNCYL*	Sliding Door Escape Deadlock, LH Escape Turn and Adaptor
3573DERSCNYL*	Sliding Door Escape Deadlock, RH Escape Turn and Adaptor
3573PTSC*	Sliding Door Through Fix Privacy Deadbolt with Deadlock Turn Adaptor

*Also available in Chrome Plate and Polished Brass finishes

3573 Series Sliding Door Deadlocks

These locks have various deadlocking functions which can be operated by key outside and by turnknob or key inside.

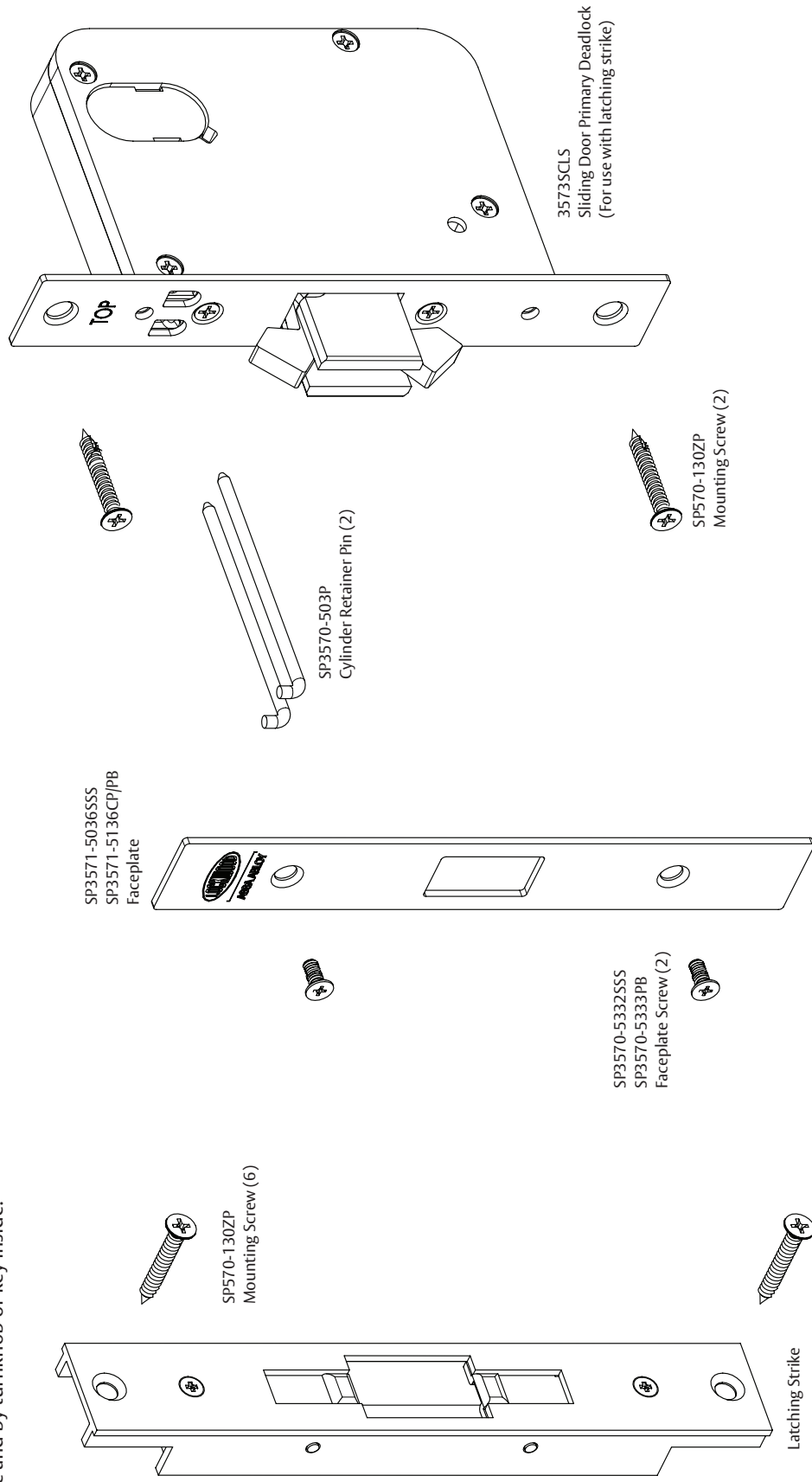

3573 Series Sliding Door Deadlock Self Latching

Orderable Locks

3573SCLS*	Sliding Door Deadlock Primary Lock with Latching Strike
3573AFSCLS	Sliding Door Deadlock Primary Lock with Aluminium Fixing Tabs with Latching Strike
3573DELSNCYLLS*	Sliding Door Escape Deadlock, LH Escape Turn and Adaptor with Latching Strike
3573DERSNCYLLS*	Sliding Door Escape Deadlock, RH Escape Turn and Adaptor with Latching Strike

*Also available in Chrome Plate and Polished Brass finishes
Note: Latching Strike is included with the above Lock kits. The lock has been specially modified to suit the latching strike.

3577 Series Dual Entry Lock

Designed to enable emergency services to enter specific areas by second cylinder without giving access to all lockset in the building and the ability to lockout keys with restricted access at certain times.

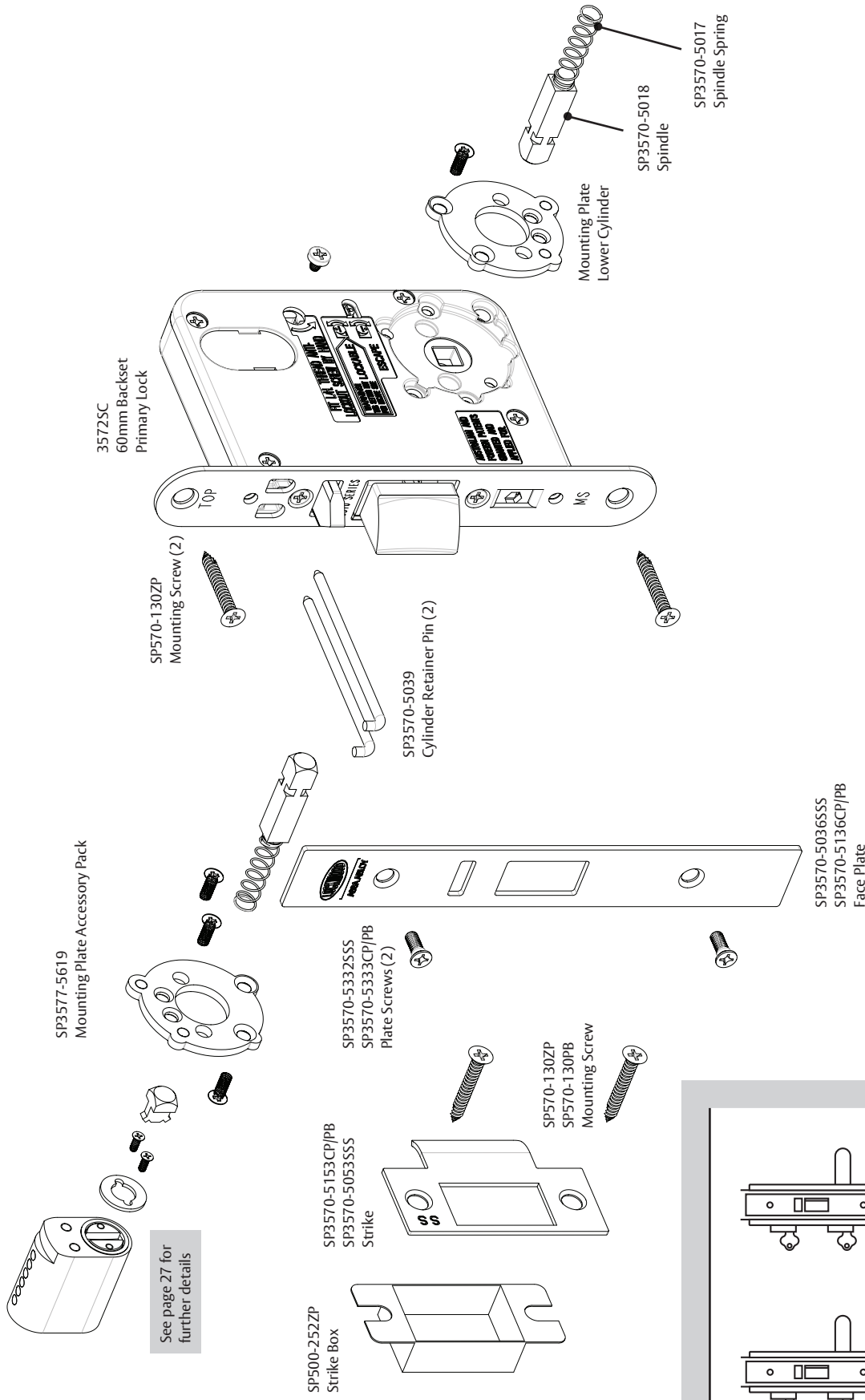

3577 Series Dual Locks

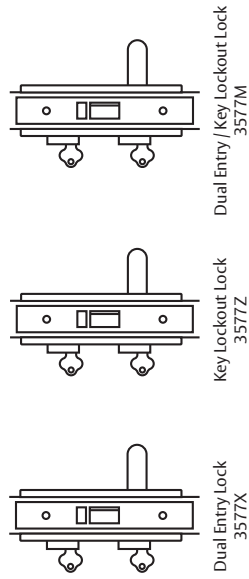

3577 Series Dual Entry Lock

Primary Lock

35775C* Dual Entry Primary Lock - No Cylinders

* Also available in Chrome Plate and Polished Brass finishes.

3578 Series Holdback Lock

A deadlatching lockset for applications where latch hold - back is required such as high use doors and toilet doors.

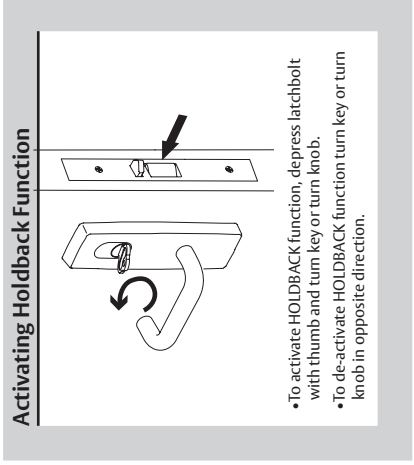
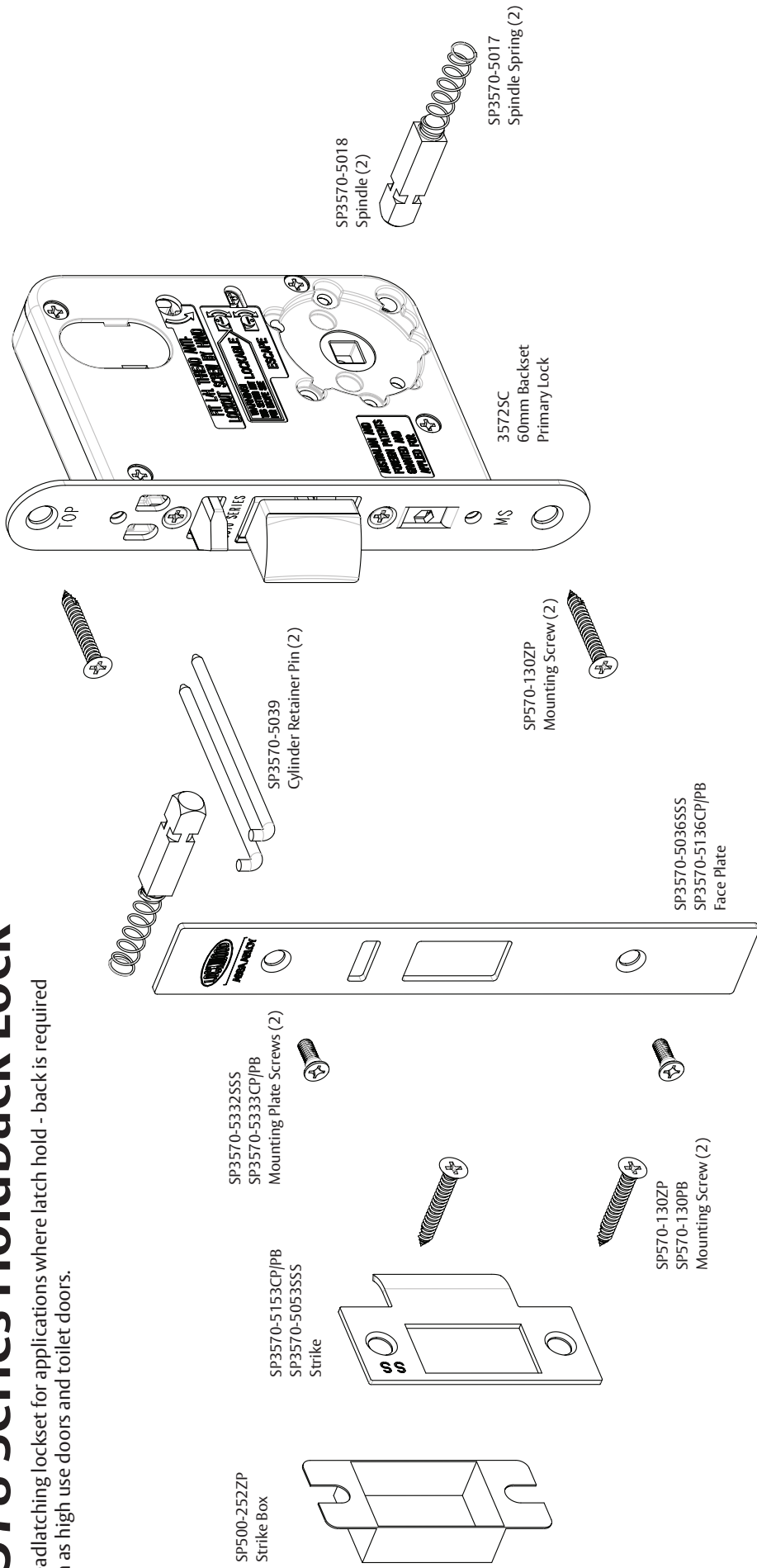

- To activate HOLDBACK function, depress latchbolt with thumb and turn key or turn knob.
- To de-activate HOLDBACK function turn key or turn knob in opposite direction.

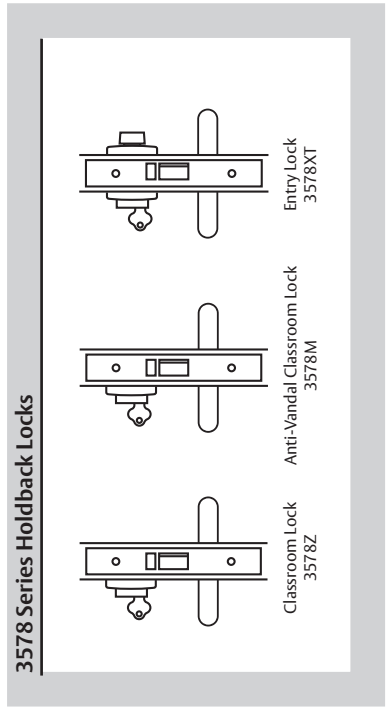

3578 Series Holdback Lock

Orderable Locks

3578SC*	Primary Mortice Lock Holdback
3578AFSC	Holdback Primary Lock Aluminium Fix

*Also available in Chrome Plate and Polished Brass finishes.

3579 Series SSEC Secure Area Mortice Locks

For use and high security Government, institutional and commercial projects.

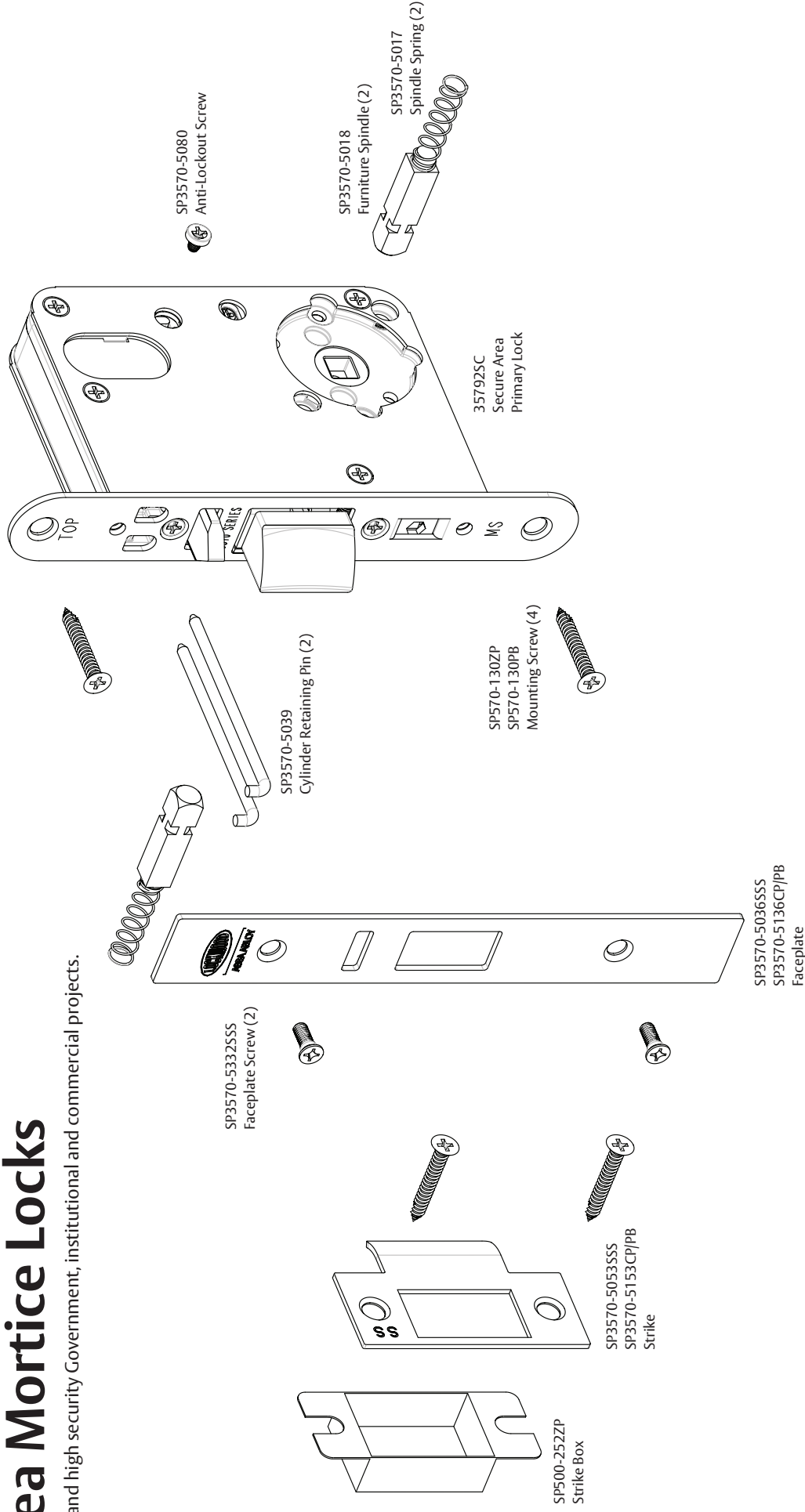

3579 Series Secure Area Rated Locks

Orderable Locks

35790SC	Secure Area Nightlatch Primary Lock
35791SC	Secure Area Deadbolt Primary Lock
35792SC	Secure Area Multi-Function Primary Lock

3572AF Aluminium Fix Lock

A deadlatching lockset for applications where latch hold - back is required such as high use doors and toilet doors.

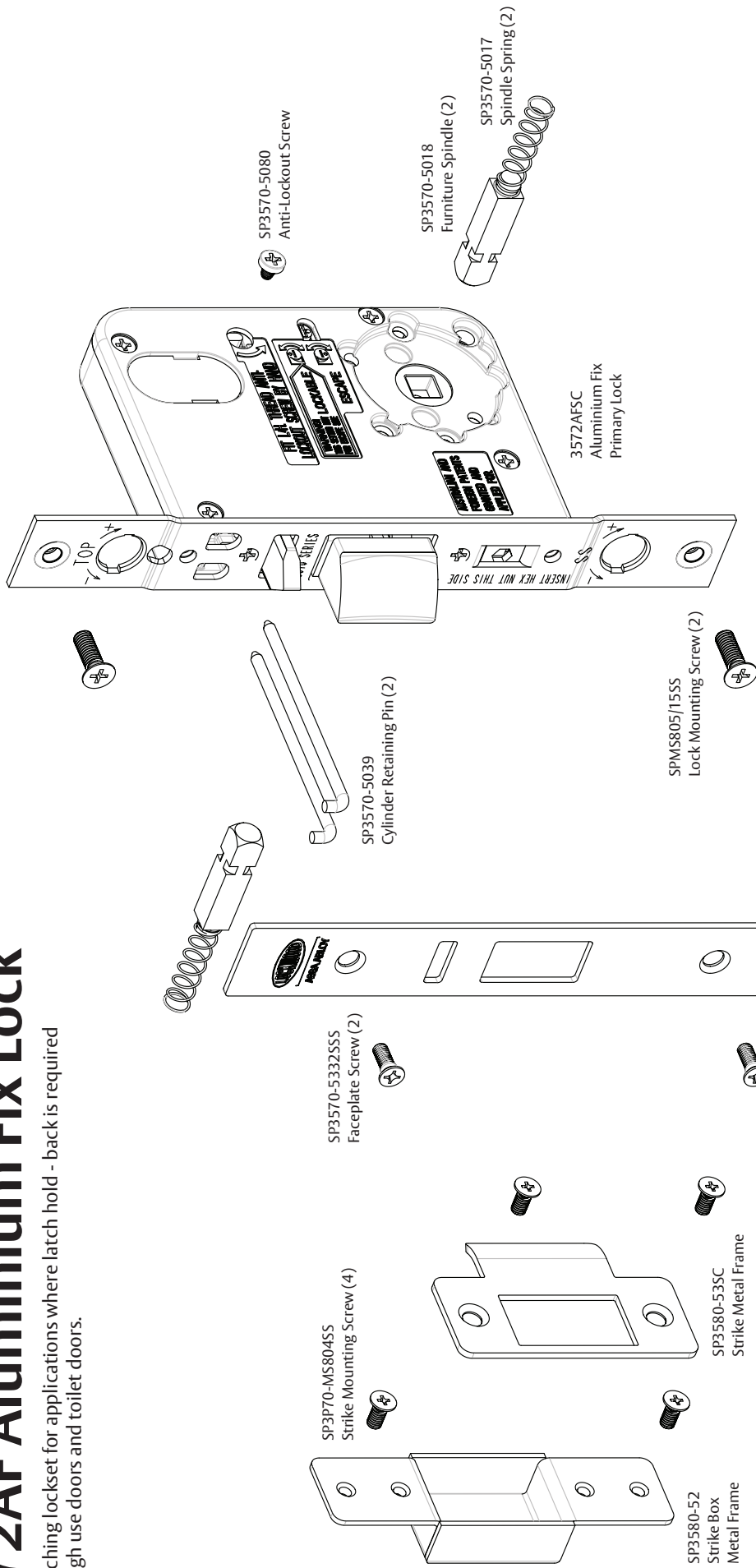

3570 Series Aluminium Fix Locks

Orderable Locks

SP3570-5036SSS

SP3570-5136CP/PB
Faceplate

3570AFSC Nightlatch Primary Lock Aluminium Fix

3571AFSC Deadlock Primary Lock Aluminium Fix

3572AFSC Multi-function Primary Lock Aluminium Fix

3574AFSC Passage Latch Aluminium Fix

3573AFSC Sliding Door Deadlock Primary Lock Aluminium Fix

3573AFSCLS Sliding Door Deadlock Primary Lock Aluminium Fix with Latching Strike

3578AFSC Holdback Primary Lock Aluminium Fix

4570 Series 89mm Extended Backset Mortice Locks

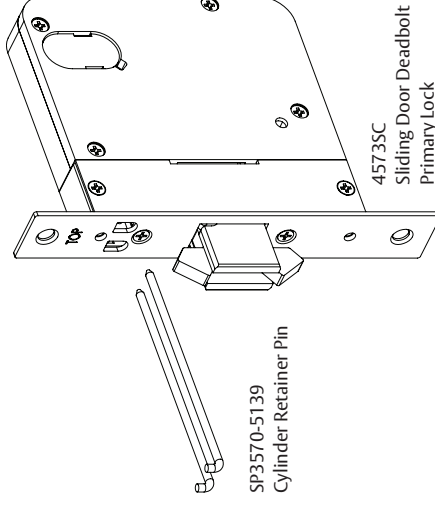
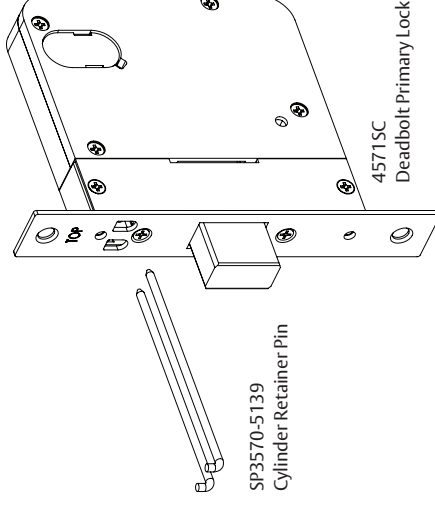
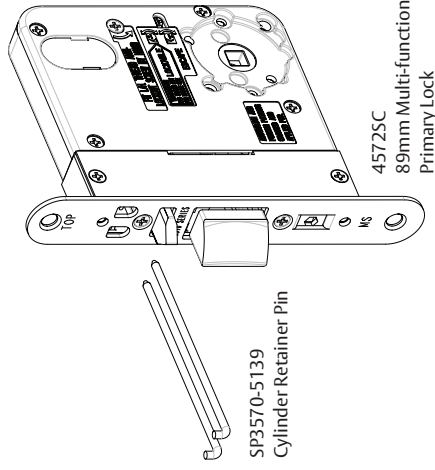

4570 Series 89mm Extended Backset Locks

Orderable Locks

4570SC*	Nightlatch Primary Lock
4571SC	Deadbolt Primary Lock
4571AFSC	Deadlock Primary Lock with Aluminium Fixing Tabs
4571DELSNCYL	Escape Deadlock, LH Escape Turn and Adaptor
4571DERSNCYL	Escape Deadlock, RH Escape Tur and Adaptor
4571PTSC	Through Fix Privacy Deadbolt with Deadlock Turn Adaptor
4572SC*	Multi-function Primary Lock
4572AFSC*	Multi-function Primary Lock Aluminium Fix
4572XALSNCYL	Anti-vandal Anti-lockout Lock Case and Adaptor Left Hand
4572XARSNCYL	Anti-vandal Anti-lockout Lock Case and Adaptor Right Hand

4573SC*	Sliding Door Deadlock Primary Lock
4573AFSC	Sliding Door Deadlock Primary Lock with Aluminium Fixing Tabs
4573DELSNCYL*	Sliding Door Escape Deadlock, LH Escape Turn and Adaptor
4573DERSNCYL*	Sliding Door Escape Deadlock, RH Escape Turn and Adaptor
4573PTSC*	Sliding Door Through Fix Privacy Deadbolt with Deadlock Turn Adaptor
4573SCLS*	Sliding Door Deadlock Primary Lock with Latching Strike
4574SC*	Passage Latch, Plainlatch Only
4578SC*	Primary Mortice Lock Hold Back
4579TSC	Secure Area Deadbolt Primary Lock
4579JSC	Secure Area Multi-function Primary Lock

5570 Series 127mm Extended Backset Mortice Locks

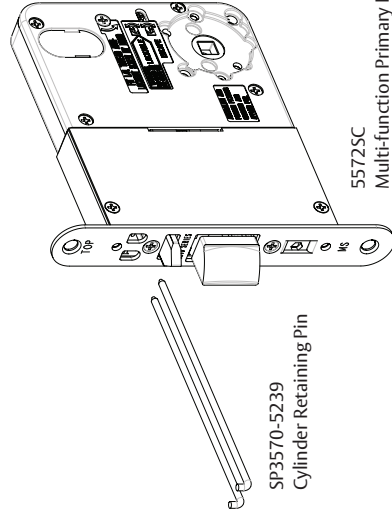

SP3570-5239
Cylinder Retaining Pin

5572SC
Multi-function Primary Lock

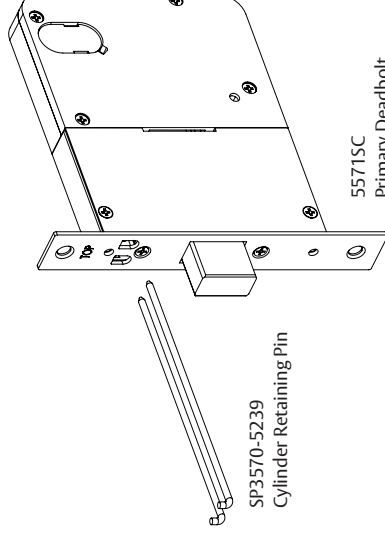

SP3570-5239
Cylinder Retaining Pin

5571SC
Primary Deadbolt

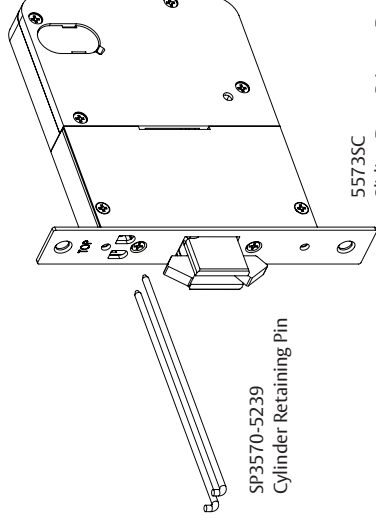

SP3570-5239
Cylinder Retaining Pin

5573SC
Sliding Door Primary Deadbolt

5570 Series 127mm Extended Backset Locks

Orderable Locks

5570SC* Nightlatch Primary Lock

5571SC* Deadlock Primary Lock

5571AFSC Deadlock Primary Lock with Aluminium Fixing Tabs

5571DELSNCYL Escape Deadlock, LH Escape Turn and Adaptor

5571IDERSNCYL Escape Deadlock, RH Escape Turn and Adaptor

5571PTSC Through Fix Privacy Deadbolt with Deadlock Turn Adaptor

5572SC* Multi-function Primary Lock

5572AFSC Multi-function Primary Lock Aluminium Fix

5572XALSNCYL Anti-vandal Anti-lockout Lock Case and Adaptor Left Hand

5572XARSNCYL Anti-vandal Anti-lockout Lock Case and Adaptor Right Hand

5573SC* Sliding Door Deadlock Primary Lock

5573AFSC Sliding Door Deadlock Primary Lock with Aluminium Fixing Tabs

5573DELSNCYL* Sliding Door Escape Deadlock, LH Escape Turn and Adaptor

5573IDERSNCYL* Sliding Door Escape Deadlock, RH Escape Turn and Adaptor

5573PTSC* Sliding Door Through Fix Privacy Deadbolt with Deadlock Turn Adaptor

5573SCLS* Sliding Door Deadlock Primary Lock with Latching Strike

5574SC* Passage Latch, Plainlatch Only

5578SC* Primary Mortice Lock Hold Back

55791SC Secure Area Deadbolt Primary Lock

55792SC Secure Area Multi-function Primary Lock



ASSA ABLOY

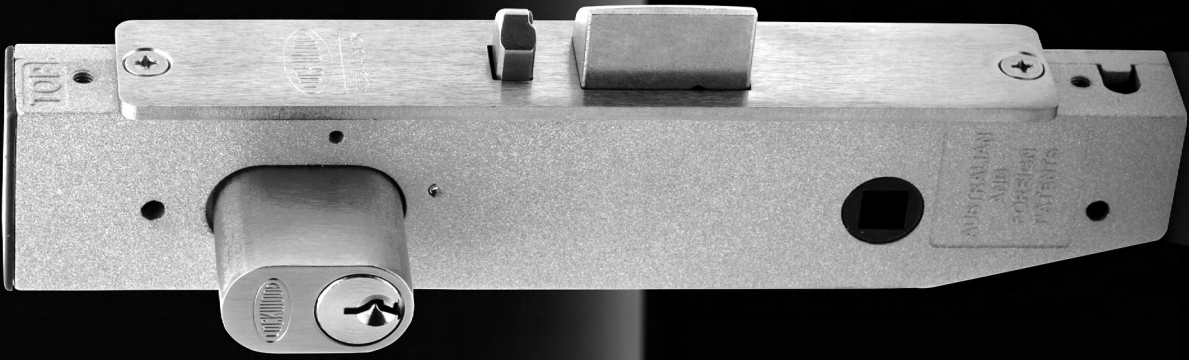

Synergy 3580 Series

3582/3584 Series Multi-Function Short Backset Locks

Various latching functions operated generally by key or handle outside and by turnknob, key or handle inside. These locks comply with building regulations for single - action escape doors.

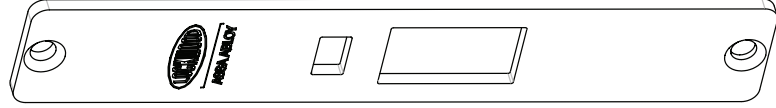

SP3P70-MS804SS
Strike/Face plate screw (8)



SP3580-52
Strike Box Metal Frame

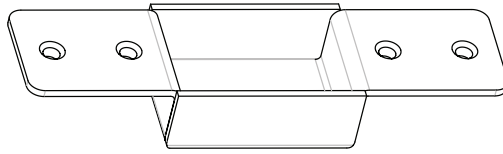

SP3580-53SC
Strike Metal Frame

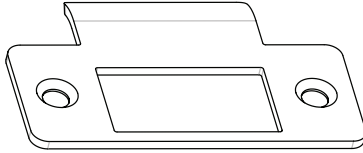

Cylinder Retainer Pin (2)
SP3580-39

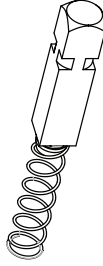

Spindle (2)
SP3570-5018

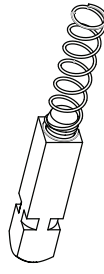

Spindle Spring (2)
SP3570-5017

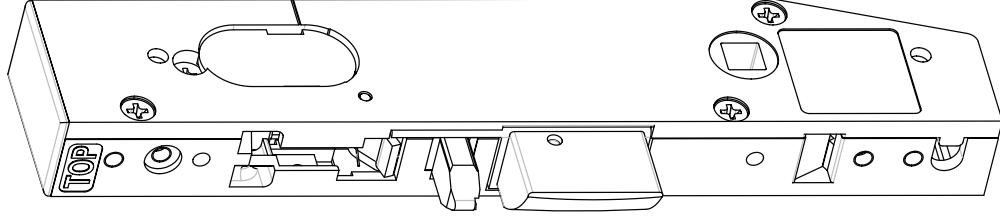

3582SC
23mm Backset Primary Lock

3580 Series Short Backset Multi-Function Locks - Metal Fixing

Orderable Locks

3582SC* 23mm Backset Primary Lock - Metal Fixing

3582 - ASC 23mm Backset Anti - lock Primary Lock

*Also available in Chrome Plate and Polished Brass finishes.

3582 Series Lock Functions

Escape Function Locks

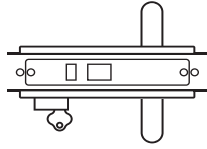

Storeroom Lock
3582X

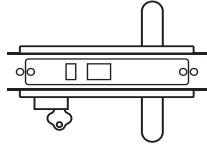

Classroom Lock
3582Z

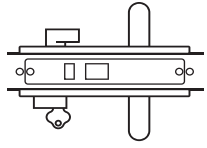

Entry Door Lock
3582XT

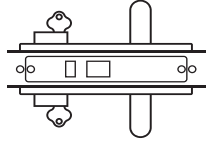

Double Cylinder Escape Lock
3582XZ

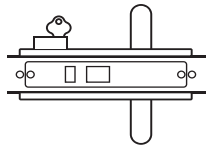

Single Cylinder Exit Door Lock
3582-Z

Escape Function Locks (continued)

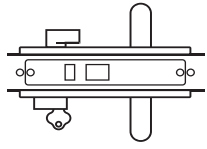

Escape Office Lock
3582WT

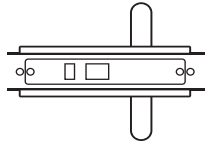

Exit Door Lock
3582-

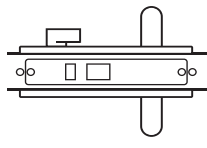

Exit Door Lock
3582-T

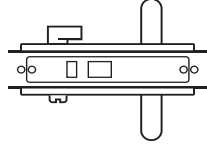

Privacy Lock
3584ET

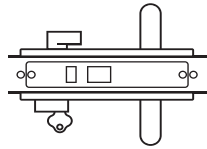

Office Lock
3584WT

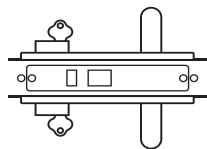

Glass Entry Door Lock
3584XZ

Combination Function Locks

Combination Function Locks (continued)

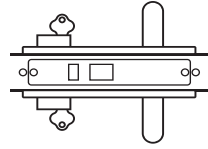

Double Cylinder Glass Door Lock
3584ZZ

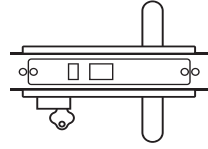

Glass Door Lock
3584Z

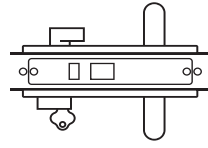

Anti-lockout Escape Lock
3582WA

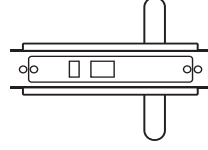

Passage Latch
3584-

Anti-lockout & Escape Function Locks

3592/3594 Series Multi-function Short Backset Locks

Various latching functions operated generally by key or handle outside and by turnknob, key or handle inside. These locks comply with building regulations for single - action escape doors.

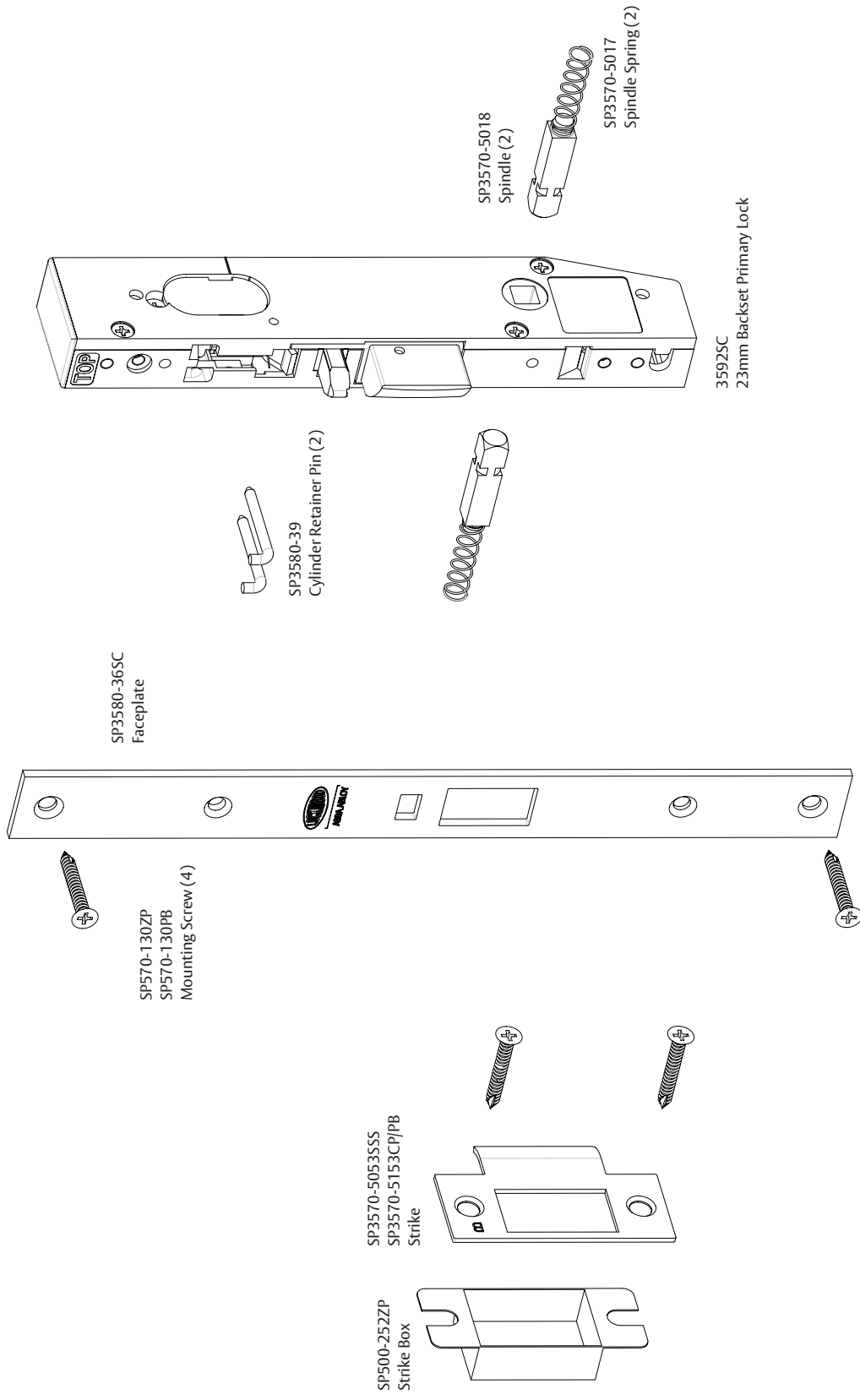

3590 Series Short Backset Multi-Function Lock - Timber Fixing

Orderable Locks

3592SC* 23mm Backset Primary Lock - Timber Fixing

*Also available in Chrome Plate and Polished Brass finishes.

4580/5580/6580 Series Extended Short Backset Locks

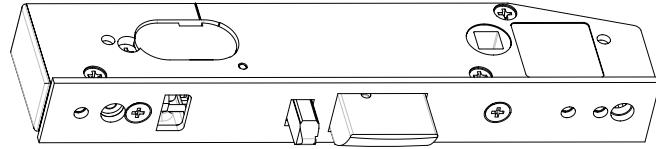

SP3580-139
Cylinder Retainer Pin

4582SC
25.4mm Backset Primary Lock

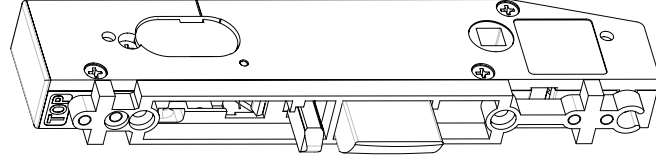

SP3580-239
Cylinder Retainer Pin

5582SC
30mm Backset Primary Lock

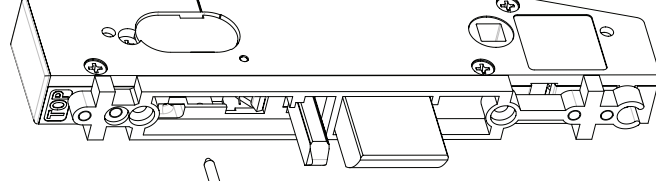

SP3580-339
Cylinder Retainer Pin

6582SC
38mm Backset Primary Lock

4580/5580/6580 Series Extended Backset Locks

Orderable Locks

4582SC*	25.4mm Backset Primary Lock - Metal Fixing
4582-ASC	25.4mm Backset Anti-lock Primary Lock
4592SC*	25.4mm Backset Primary Lock - Timber Fixing
5582SC*	30mm Backset Primary Lock - Metal Fixing
5582-ASC	30mm Backset Anti-lock Primary Lock
5592SC*	30mm Backset Primary Lock - Timber Fixing
6582SC*	38mm Backset Primary Lock - Metal Fixing
6582-ASC	38mm Backset Anti-lock Primary Lock
6592SC*	38mm Backset Primary Lock - Timber Fixing

Cylinders

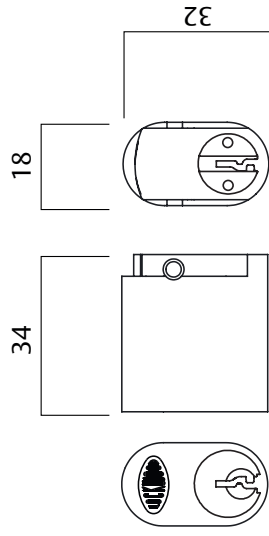

Synergy Series

"X" CAM SP570-18ZP	"Y" CAM SP571-18ZP	"Z" CAM SP572-18ZP	"W" CAM SP575-18ZP	"M" CAM W mounted upside down	"XA-R" Cam SP3572-6218

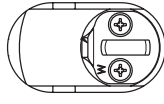

"W" Cam Cylinder 575-25C
Cam Separately SP575-18ZP

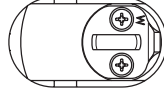

"W" Cam Cylinder 575-525C
Cam Separately SP575-18ZP
"fitted upside down"

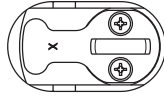

"X" Cam Cylinder 570-25C
Cam Separately SP570-18ZP

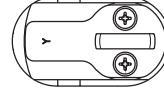

"Y" Cam Cylinder 571-25C
Cam Separately SP571-18ZP

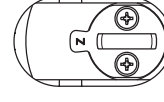

"Z" Cam Cylinder 572-25C
Cam Separately SP572-18ZP

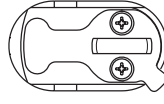

"XA-L" Cam Cylinder 570-302LHSC
Cam Separately SP3572-6118

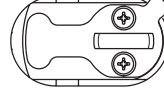

"XA-R" Cam Cylinder 570-302RHSC
Cam Separately SP3572-6128

Standard 570 cylinder

This cylinder is used on Lockwood Cylinder Mortice Locks.
The Synergy series uses various cylinder cams depending on the function required.
Cylinder is assembled as a 5 pin tumbler mechanism but is 6 pin tumbler capable.
Uses a standard 570 barrel.

Standard "C4" Assembled Cylinder Part Number

570-25C	Mortice Cylinder with "X" cam
571-25C	Mortice Cylinder with "Y" cam
572-25C	Mortice Cylinder with "Z" cam
575-25C	Mortice Cylinder with "W" cam
575-525C	Mortice Cylinder with "M" cam
570-302LHSC	Mortice Cylinder with "XA" cam Left Hand
570-302RHSC	Mortice Cylinder with "XA" cam Right Hand

Cylinders

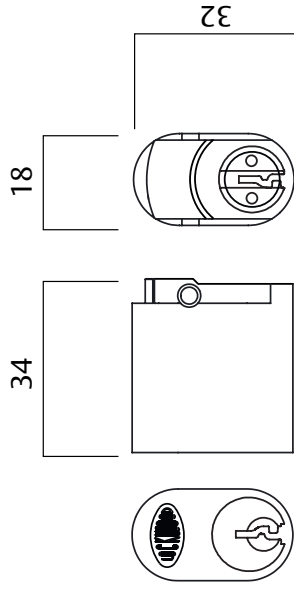

H/B CAM RETAINER PLATE
SP3570-5118

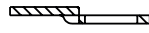

3580 H/B CAM
SP3580-5125

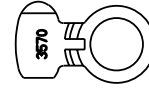

RH 3570 H/B CAM
SP3570-5125

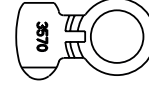

LH 3570 H/B CAM
SP3580-5625

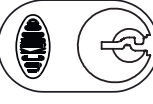
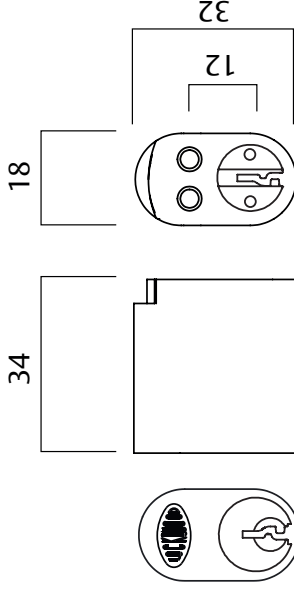

Ⓐ CYLINDER SPINDLE RETAINER PLATE
SP8489-12

Ⓑ CYLINDER SPINDLE
SP3570-5167ZP

Synergy Hold Back Cylinder

This cylinder is used on Lockwood Synergy Mortice Locks for a hold back function. It has a stepped back and the cam assembly is made up of two pieces - the cam and the retainer plate. Cylinder is assembled as a 5 pin tumbler mechanism but is 6 pin tumbler capable. Uses special hold back barrels (570 barrels will not fit with this application)

Standard "C4" Assembled Cylinder Part Number

3580-2402SC	Synergy Hold Back Cylinder RH for 3580 series
3580-2452SC	Synergy Hold Back Cylinder LH for 3580 series
3570-2402SC	Synergy Hold Back Cylinder RH for 3570 series
3570-2452SC	Synergy Hold Back Cylinder LH for 3570 series

Note: Handling assumes the cylinder is fitted to the outside of the door

Synergy Dual Lower Cylinder

This cylinder is used as the dual lower cylinder in the Synergy range. Also used for the Inline Airlock (trailer lock). This cylinder is not compatible with the new Pentagon series dual cylinder function. Cylinder is assembled as a 5 pin tumbler mechanism but is 6 pin tumbler capable. Uses a standard 570 barrel.

Standard "C4" Assembled Cylinder Part Number

577-25C	Synergy Dual Lower Cylinder for 3577 series
---------	---

Cylinders

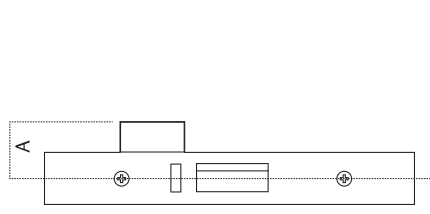
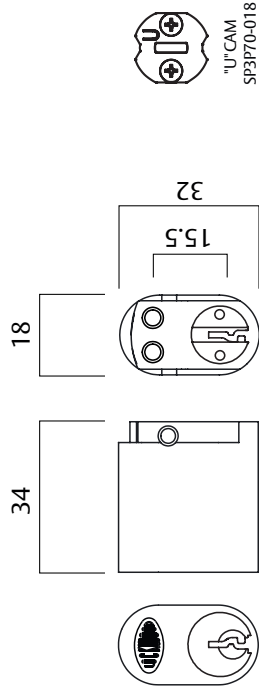

Screws

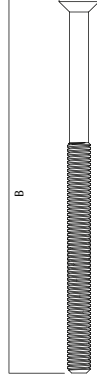

Screws are available in 4 sizes which can be cut and deburred to the desired length.

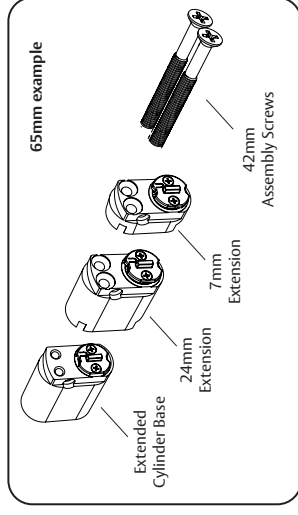
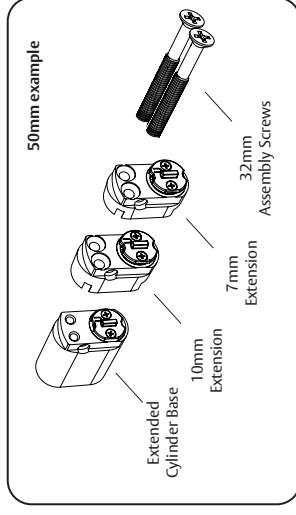

An extension guide is included to show the parts required for a particular length:

Overall Cylinder Length Required	Cylinder Projection (A)	Door Thickness	Extended base Cylinder	7mm Extension Kit	10mm Extension Kit	24mm Extension Kit	32mm Assembly Screw	42mm Assembly Screw	65mm Assembly Screw
34	36	35	49						
41	43	49	63	1	1				2
50	53	63	83	1	1				2
61	63	83	103	1	1	2			2
65	67	93	98	1	1				2
72	74	103	123	1	2				2
82	84	123	143	1		2			2
92	94	143	163	1	1				2

Standard Mortise Cylinder

Standard "C4" Assembled Cylinder Part Number

570E/5C	Extended Cylinder Base with "U" cam
570E/50WSC	50mm Extended Cylinder Assembly with "W" cam
570E/50XSC	50mm Extended Cylinder Assembly with "X" cam
570E/50ZSC	50mm Extended Cylinder Assembly with "Z" cam
570E/65WSC	65mm Extended Cylinder Assembly with "W" cam
570E/65XSC	65mm Extended Cylinder Assembly with "X" cam
570E/65ZSC	65mm Extended Cylinder Assembly with "Z" cam

Assembly Screws

Part Number	Pack Size	Length(B)	Min-Max Extension (mm) If screw uncut
SRWM4-3ZSS	10	32	7-24
SRWM4-4ZSS	10	42	14-36
SRWM4-65SS	10	65	37-58
SRWM4-75SS	10	75	47-68

Extension Kits

Part Number	Pack Size
570/EXT07	5
570/EXT10	5
570/EXT24	5

3570 Series Alternative Finish Kits

Non standard finish kits include: Strike, Faceplate and Screws

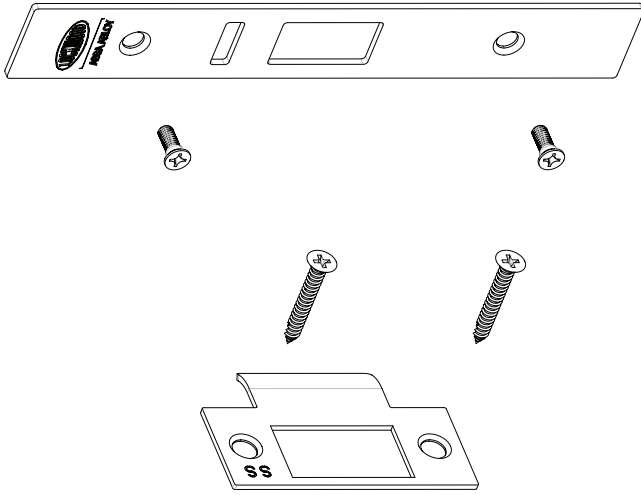

Alternative Finish Kits

3570 Series Non-standard Finish Kit Includes: Strike, Face Plate & Screws

3570-AZKIT	Architectural Bronze
3570-CPKIT	Chrome Plate
3570-ORBKIT	Oil Rubbed Bronze
3570-PBKIT	Polished Brass
3570-BUKIT	Polished Brass Unlaquered
3570-PCKIT	Powder Coat

3580 Series Alternative Finish Kits

Non standard finish kits include: Strike, Faceplate and Screws

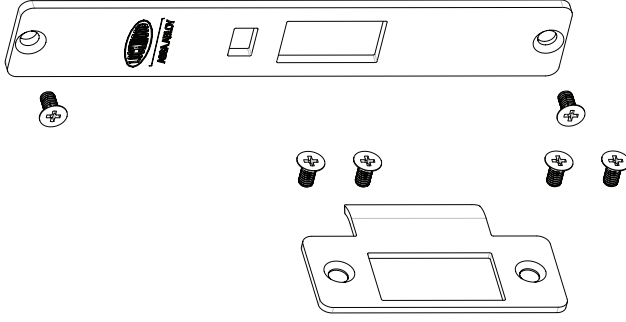

Alternative Finish Kits

3580 Series Non-standard Finish Kit Includes: Strike, Face Plate & Screws

3582-CPKIT	Chrome Plate
3582-PBKIT	Polished Brass
3582-PCKIT	Powder Coat

Rebate Kit - to suit 3570 Series Locks (4HR Fire Rated)

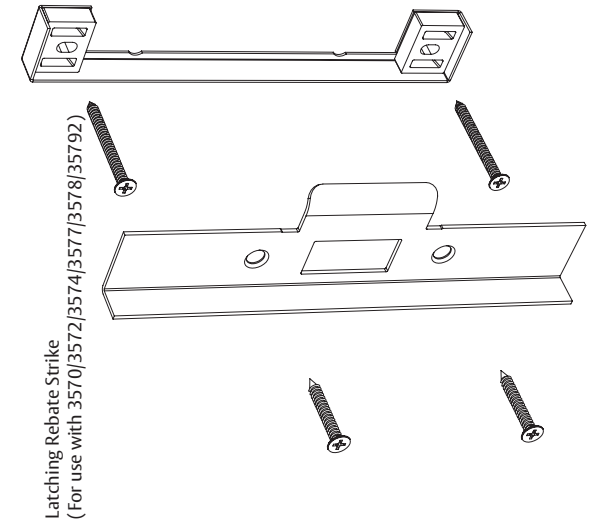

3571-2902
Deadlock/Rebate Strike
(For use with 3571/3573)

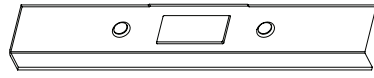

Lip Length	Rebate Kit Part Number
32mm	3P72 - RK32SS
46MM	3P72 - RK46SS
No Lip	3571 - 2902SC

Rebate Kit - to suit 3580 Series Locks

For use with a minimum of 30mm backset lock (5582)

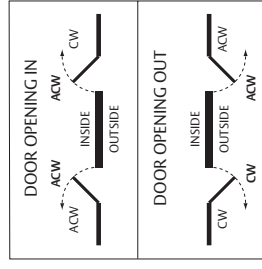
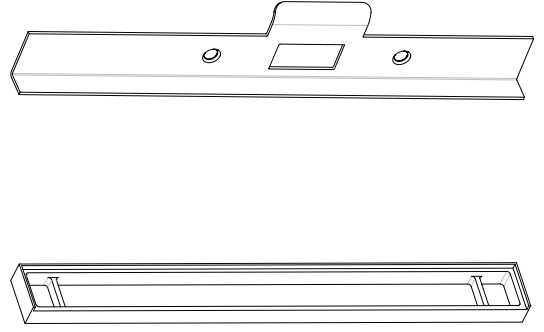

CW (Clockwise)	Left Hand open in
ACW (Anti-Clockwise)	Right Hand open out
	Left Hand open out
	Right Hand open in

Part Numbers	Chrome Plate	3580-2902	CW / ACW CP
	Satin Chrome Brushed	3580-2902	CW / ACW SC
	Polished Brass	3580-2902	CW / ACW PB

*Specify door handing (Clockwise/anti-clockwise).

Accessories

3570 Series Aluminium Door Mounting Brackets

Can be used to mount any standard 3570 Series lock into a hollow section.

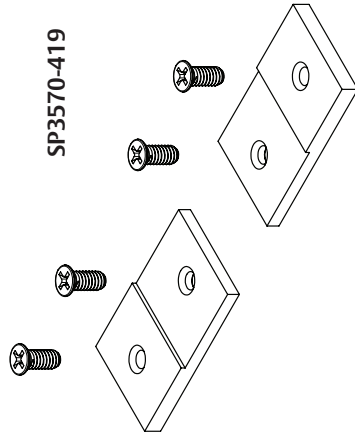

Mortice Lock Spindles

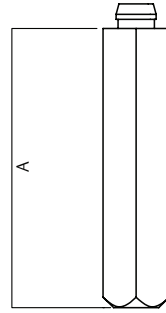

Part Number	Pack Size	Length "A"	Door Thickness	
			Min	Max
SP3570 - 5018	10	33mm	35	50
SP3570 - 5228	10	45	50	75
SP3570 - 5238	1	58	75	100
SP3570 - 5258	10	108	100	200
SP3570 - 5328	10	125	200	240

Note: 33mm length supplied in accessory pack with primary lock.

Strike Plate Kits

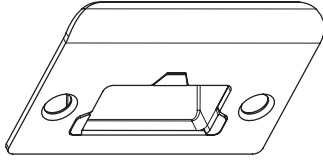

Standard Fabricator Strike 32mm
SP3P80 - 053SS

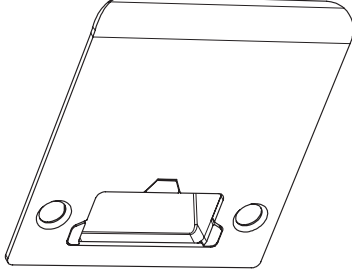

Extended Fabricator Strike 64mm
SP3P80 - 153SS

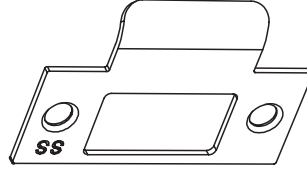

Standard Strike
SP3570 - 5053SSS

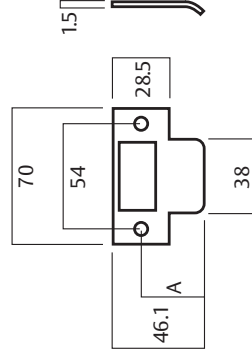

Standard Strike Plate "A"

SP3570-4053	25.4mm
SP3570-5053	32mm
SP3570-5253	43.5mm
SP3570-5453	47.5mm

Retrofit Strikes

For replacement of existing installations where Lockwood 5900, 595 and Astra Short Backset are used. For replacement of Astra specify 25.4mm backset.

Part Numbers

Chrome Plate	3580-1902CP
Satin Chrome Brushed	3580-1902SC
Polished Brass	3580-1902PB

Adaptors

If using Case Fix Turns or Robert Watson turns a notched turn adaptor is required. Simply change the 5 after the dash to a 6 ie. SP3572-5250 becomes SP3572-6250.

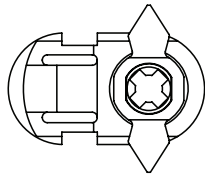

SP3572-5250
Standard Turn Adaptor

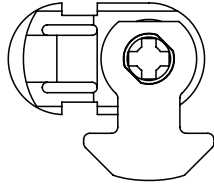

SP3570-5050
Nightlatch Turn Adaptor

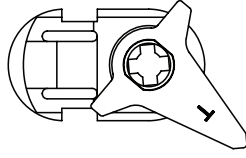

SP3571-5050
Deadlock Turn Adaptor

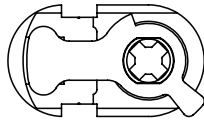

SP3572-5350
Anti-vandal Turn Adaptor (RH)

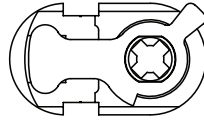

SP3572-5450
Anti-vandal Turn Adaptor (LH)

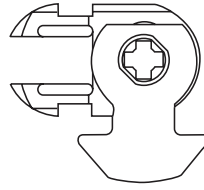

SP3570-6050
Nightlatch Turn Adaptor
(for Case Fix Turns)

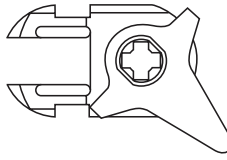

SP3571-6050
Deadlock Turn Adaptor
(for Case Fix Turns)

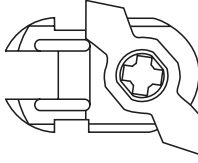

SP3572-6250
Standard Turn Adaptor
(for Case Fix Turns)

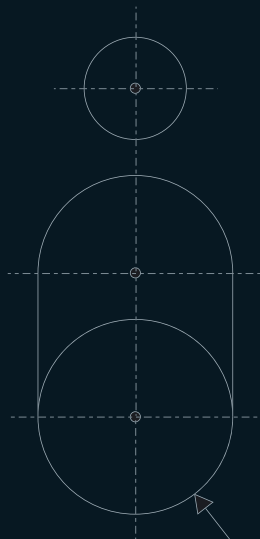
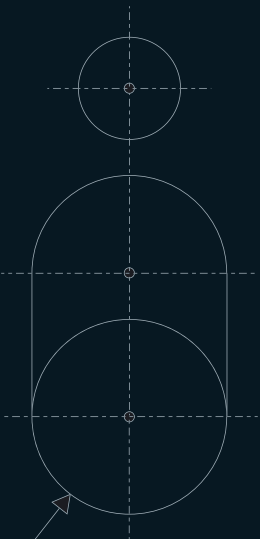

Mounting Instructions and Templates

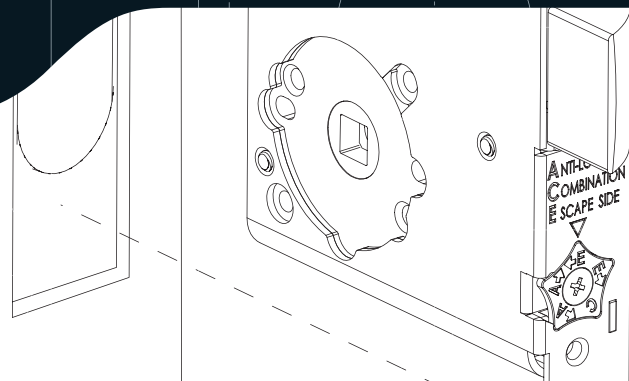
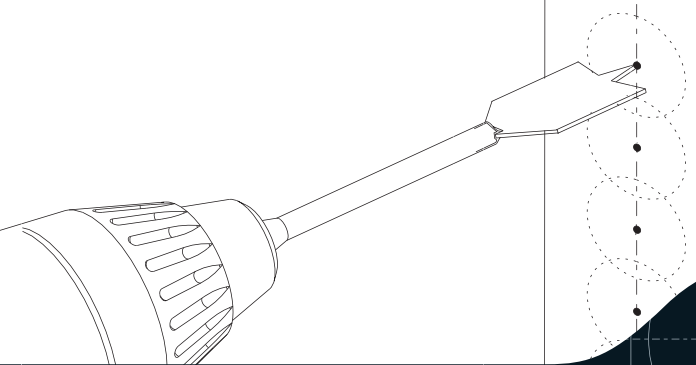

ASSA ABLOY

3572 SERIES MORTICE LOCK MOUNTING INSTRUCTIONS

P/No. 3570-5121 30621 0508

HAND OF DOOR ACCORDING TO ENGLISH PRACTICE

RIGHT - HAND DOOR		LEFT - HAND DOOR	
OUTSIDE DOOR OPENING IN	OUTSIDE DOOR OPENING OUT	OUTSIDE DOOR OPENING IN	OUTSIDE DOOR OPENING OUT

- Determine hand of lock required from hand of door chart above.
- All Lockwood 3572 Series Mortice Locks are mounted in accordance with these instructions. Locks may or may not have cylinders, lever handles, turn knob or emergency button. Disregard instructions referring to the features not required.
- Important : Before drilling door, ensure correct hand is being installed.
- NOTE: CASE DOES NOT need to be opened, to change HAND or FUNCTION of LOCK.

HANDING OF LOCK

- Determine hand of lock required from above hand of door chart.
- Rotate bolt head to suit latching direction.

1

SETTING LOCK STATUS

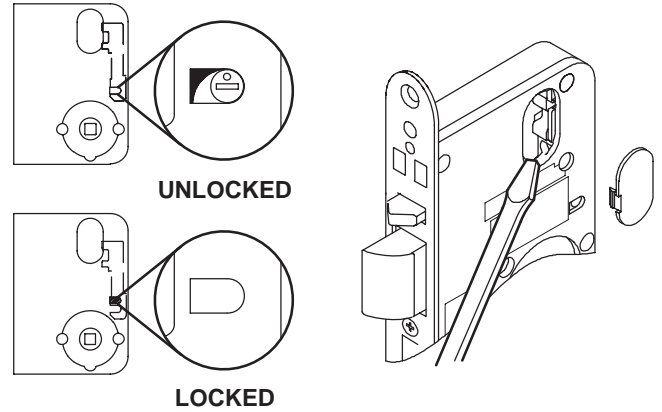

- Ensure lock is in UNLOCKED position.
- To UNLOCK (if required), using a small screwdriver, lever out Cylinder Hole Plug where fitted and lift snib using the screwdriver.

2

SETTING LOCK STATUS

COMBINATION

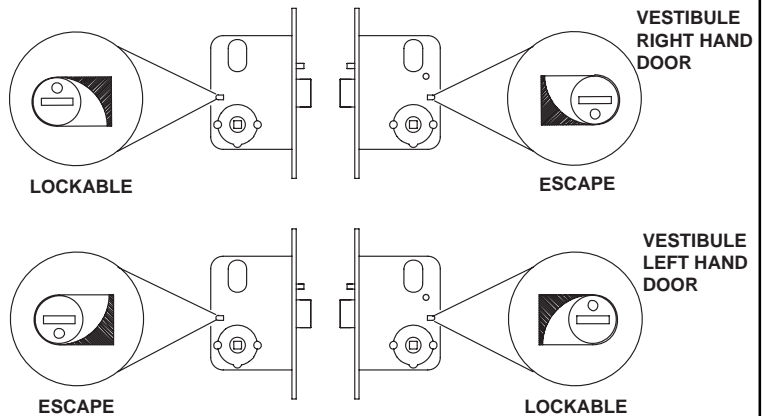
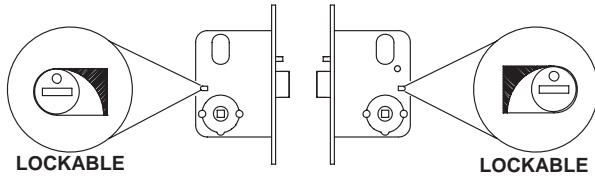

- **SNIB CAM**
Rotation of the Snib Cam hands the lock. Use a small screwdriver to rotate cam if required.
- **Combination locks**
(Both handles can be locked) DOT in the up position.

- **Vestibule Locks**
With single action escape feature. DOT to be DOWN on ESCAPE side and UP on LOCKABLE side.

3

SETTING KICK-OFF FUNCTION

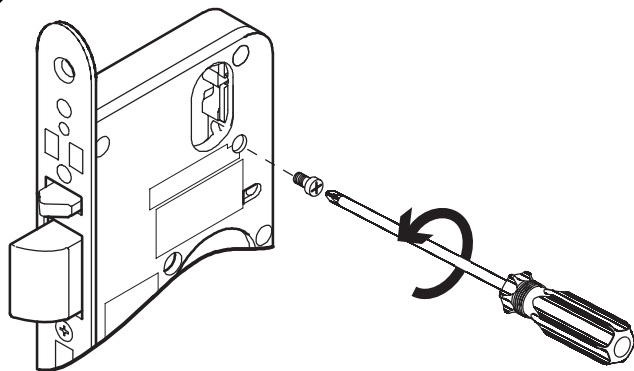

- To activate KICK-OFF function, ensure the lock is unlocked, then insert the KICK-OFF screw as shown. Rotate screw in the direction of the arrow as the screw is left hand thread.
Do not use power driver for this application as you may strip the screw thread.

4

TURN KNOB ADAPTORS

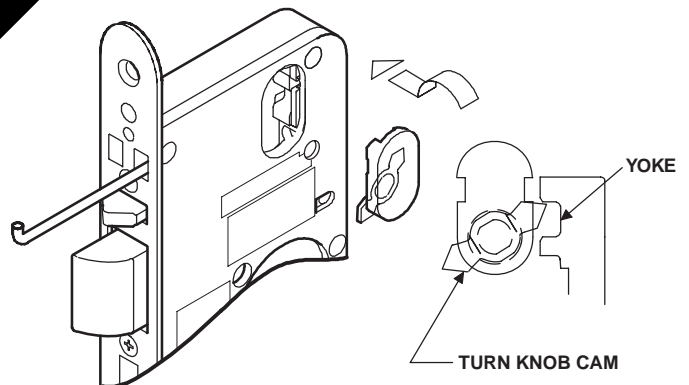

- Establish which side the adaptor is to be located, lever out Cylinder hole plug where fitted.
- **PUT LOCK IN LOCKED POSITION, as shown in Step 1.**
- Insert Adaptor into lock body with TOP of Turn Knob Cam point away from front of lock body. **Ensure Turn Knob Cam is engaged in yoke of snib as shown.**
- Place retainer pin through front plate to retain adaptor to lock. Ensure pin is flush with front plate

3572 SERIES MORTICE LOCK MOUNTING INSTRUCTIONS

5 DOOR PREPARATION

IMPORTANT - To prevent damage to the door face from drill "breakthrough", MARK BOTH SIDES OF DOOR & DRILL HOLES HALF WAY THROUGH EACH SIDE

- Establish height that lockset will be mounted on door and mark centreline of door thickness on door edge.
- Place Mortise Template on door and align centreline on template with centreline on door. Secure with sticky tape.
- Mark and drill mortise to suit mortise lock depth (90mm).

6 DOOR PREPARATION

- Ease out mortise cavity where necessary. Clean out mortise before inserting lock.
- Insert lock in mortise with Cover Plate on and scribe around Cover Plate for size of recess, ensuring that no foreign matter finds its way into the lock mechanism.
- Remove lock from mortise and chisel recess 4mm deep to receive both front and cover plate. Cover plate must be flush with edge of door.
- Ensure lock is removed from mortise cavity. Fold template along backset fold line. Align EDGE A with bottom of cover plate recess. Establish holes required to suit lock function, mark hole centres accurately, drill and clean holes.
- Drill furniture holes as required.
- Fasten mortise lock into door using mounting screws provided.

7 LOCKS AND CYLINDERS

LOCKS WITH CYLINDERS

- Place lock in mortise and insert cylinder.
- Secure cylinder with retainer pin, ensuring pin is flush with front plate.
- Install Cover plate and secure with 2 M4 screws provided to lock body.

LOCKS WITHOUT CYLINDERS

- Install Cover plate and secure with 2 M4 screws provided to lock body.

8 LOCKS WITH TURNKNOBS

LATCHING OR LOCKING TURNKNOB

EMERGENCY TURNKNOB FUNCTION

- Mark and cut connecting bar as shown.
- Turn knob to be in the vertical position when UNLOCKED.

9 LOCKS WITH SPINDLES

IMPORTANT: Attach spindle spring to rear of spindle before assembling

- All locks are supplied with spindles.
- Insert spindle(s) into lock, as required.
- Assemble furniture as required. Ensure furniture is not over-tightened.

10 MOUNTING STRIKE

- Mark out door frame for strike.
- Mortise door frame for strike box and strike. Bolt recess to be 15mm deep in door frame.
- Screw strike and strike box to the door frame with two screws supplied with mortise lock.

3570 SERIES MORTICE LOCK MOUNTING INSTRUCTIONS

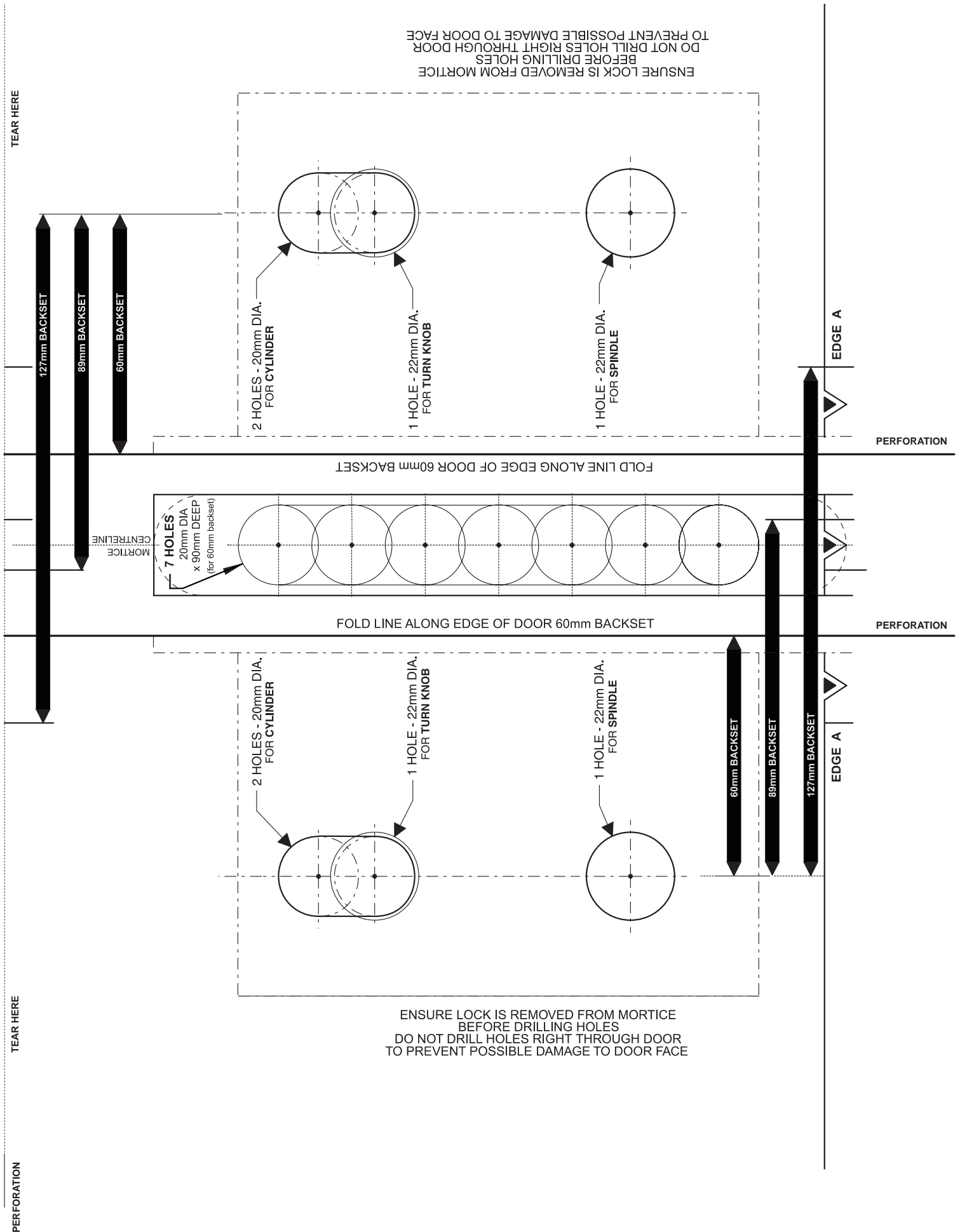

3570AF SERIES MORTICE LOCK

INSTALLATION INSTRUCTIONS WIDE ALUMINIUM STYLE DOORS

Part No. 3570AF-21 30621 0508

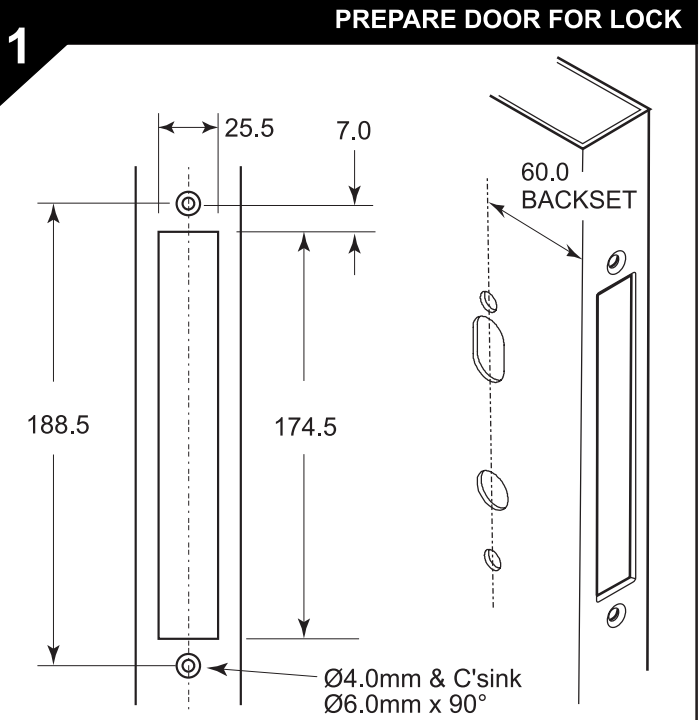

- Establish height at which lockset will be on door.
- Cut COVER PLATE window as per dimensions above.
- Using instructions and template from main instruction drill the holes for the cylinder, furniture etc.

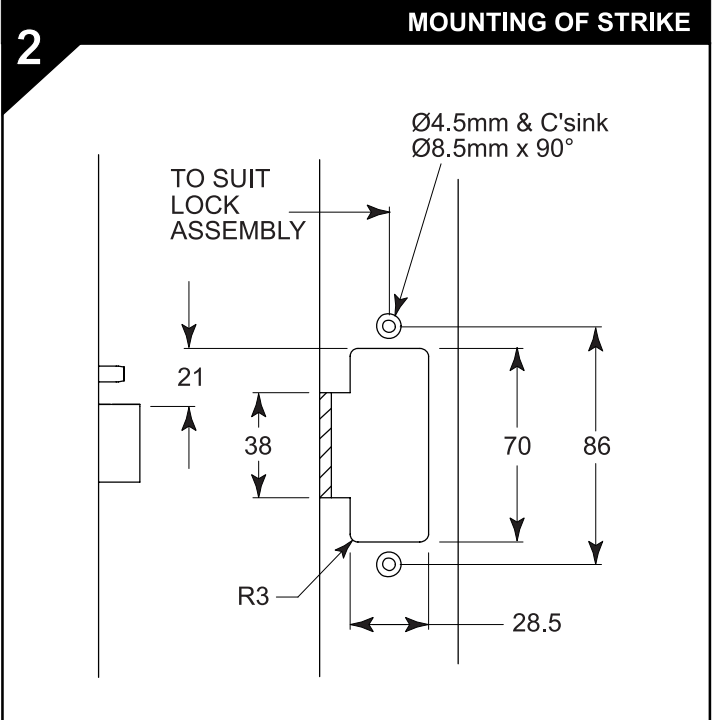

- Prepare door jamb cutout as above.
- Fit strike to strike box and then fit to frame and secure with 2 screws.



3570 SERIES MORTICE LOCK INSTALLATION INSTRUCTIONS FOR METAL DOORS

Part No. 3570-121
30621-0710

1 PREPARE DOOR FOR LOCK

198.5

174.5

25.5

13.5

Ø5.8mm & C'sink
Ø8.5mm x 90°

- Establish height at which lockset will be on door.
- Cut COVER PLATE window as per dimensions above.
- Using instructions and template from main instruction, drill the holes for the cylinder, furniture etc.

2 INSTALL MOUNT BRACKETS

No.8 x 16mm
Self-tapping screw
(supplied in bracket kit)

Metal Door Frame
mount bracket

- Secure Metal Door Frame mount brackets as shown above with two of the No.8 x 16mm screws provided in the bracket kit.

3 INSTALL MORTICE LOCK

No.8 x 16mm
Self-tapping screw
(supplied in bracket kit)

- Insert mortice lock into cavity and secure to the Metal Door Frame mount brackets with the remaining No.8 x 16mm screws supplied in bracket kit.
- Finish assembling mortice lock as per main instructions.

4 MOUNTING STRIKE

TO SUIT
LOCK
ASSEMBLY

Ø4.5mm & C'sink
Ø8.5mm x 90°

21

38

70

86

R3

28.5

- Prepare door jamb cutout as above.
- Fit strike to strike box and then fit to frame and secure with 2 screws.

3571/3573 MORTICE LOCK MOUNTING INSTRUCTIONS

USE THIS INSTRUCTION IN CONJUNCTION WITH THE RELEVANT FURNITURE MOUNTING INSTRUCTION.

Important : Before drilling door, ensure correct hand is being installed.

ESCAPE FUNCTION: External cylinder locks and unlocks bolt, Internal lever allows escape only.

Part No. 3571-121
35021-0305

RIGHT - HAND DOOR		LEFT - HAND DOOR		SLIDING DOOR	
OUTSIDE DOOR OPENING IN	OUTSIDE DOOR OPENING OUT	OUTSIDE DOOR OPENING IN	OUTSIDE DOOR OPENING OUT	OUTSIDE RIGHT HAND	OUTSIDE LEFT HAND

1 MORTICE DOOR

- Establish height that the lockset will be on the door and mark centreline of door thickness on door edge.
- Place template on door and align centreline on template with the centreline on the door. Mark and drill the mortise to the desired Backset depth.
- Ease out mortise cavity where necessary. Clean out mortise before inserting lock.
- Insert lock in mortise and scribe around front plate for size of recess.

- Remove lock from mortise and chisel recess 4mm deep to receive front and cover plate. Cover plate must be flush with edge of door.
- Ensure lock is removed from mortise cavity.** Fold template to desired backset. Align EDGE A with bottom of cover plate recess.
- Establish holes required to suit lock function, mark hole centres accurately, drill and clean holes.
- IMPORTANT**
TO PREVENT DAMAGE TO THE DOOR FACE FROM DRILL BREAKTHROUGH, MARK BOTH SIDES OF THE DOOR AND DRILL HOLES HALFWAY THROUGH EACH SIDE.

2 ASSEMBLE MORTICE LOCK

Turnknob Adaptor

- Using a small flat screwdriver, lever out cylinder hole plugs if present.
- With the bolt extended, insert the Turnknob adaptor into the interior side of the mortise lock with the adaptor lever pointing forward.

- Ensure bolt is fully extended and assemble into mortise. Fix with two screws provided.

3 ASSEMBLE ESCAPE TURN LEVER

- Ensure bolt is fully extended and Escape turn lever is in the up position.
- Assemble Escape turn lever onto rose/furniture plate and engage into mortise lock.
- Insert cylinder retaining pin to secure Escape turn lever assembly.
- Secure rose/furniture plate to door with two screws provided.

4 ASSEMBLE TRIM

- Assemble rose escutcheon.
- For other furniture plate configurations, refer relevant furniture plate mounting instructions.**

TURKNOB ASSEMBLY

STANDARD TURKNOB	EMERGENCY TURKNOB FUNCTION
<ul style="list-style-type: none"> Mark and cut connecting bar as shown. Turn knob to be in the vertical position when UNLOCKED. 	

5 ASSEMBLE CYLINDER

- Insert cylinder and secure with cylinder retaining pin.
- Assemble external rose to door with 2 screws provided.
- Attach coverplate as shown.
- Assemble rose escutcheon.

3571/3573 MORTICE LOCK MOUNTING INSTRUCTIONS

6

ASSEMBLE STRIKE - 3571

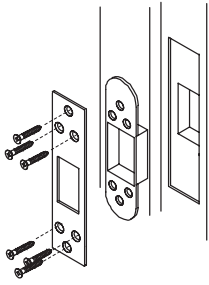

- Mark out door frame for strike.
- Mortice door frame for strike box and strike. Bolt recess to be 20mm Deep in door frame.
- Screw strike and strike box to the door frame with the screws provided.

ASSEMBLE STRIKE - 3573 Sliding Door Function

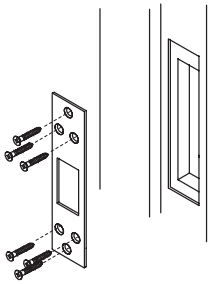

- Mark out door frame for strike.
- Mortice door frame for strike and mortice a 20mm Deep recess for the bolt head to clear the locking lugs.
- Screw strike and strike box to the door frame with the screws provided.

FITTING TURNKNOBS FOR PT SERIES PRIVACY DEADBOLTS

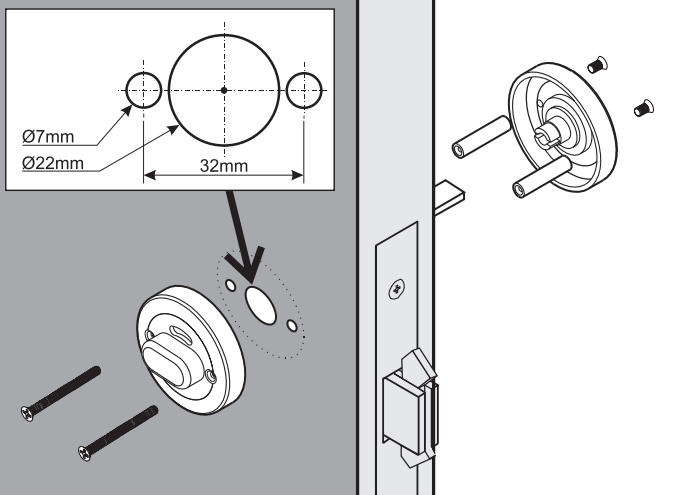



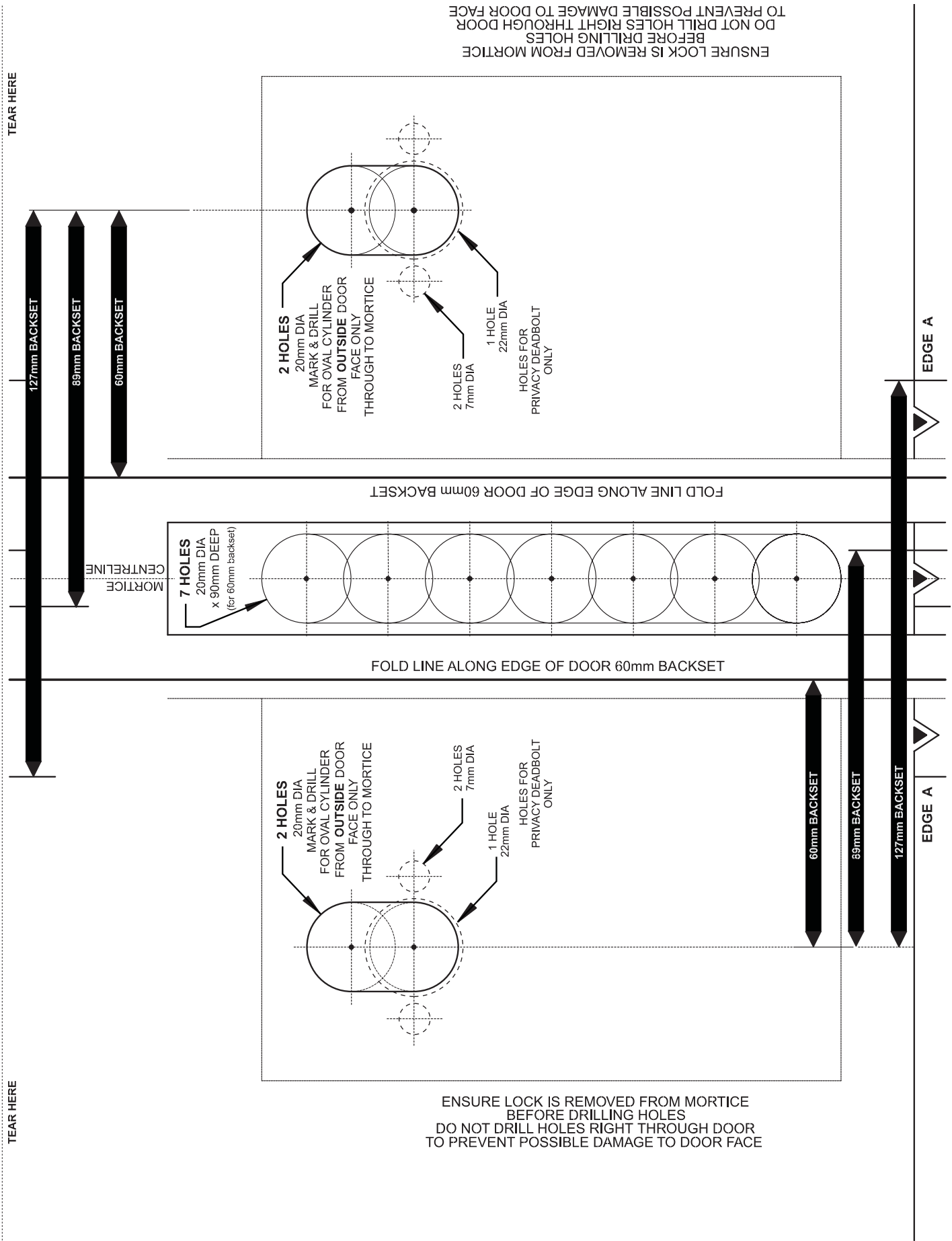

3571/3573 MORTICE LOCK MOUNTING INSTRUCTIONS



3577 SERIES DUAL ENTRY MORTICE LOCK MOUNTING INSTRUCTIONS

P/No. 3577-5121_30621 1009

HAND OF DOOR ACCORDING TO ENGLISH PRACTICE

RIGHT - HAND DOOR		LEFT - HAND DOOR	
			
OUTSIDE DOOR OPENING IN	OUTSIDE DOOR OPENING OUT	OUTSIDE DOOR OPENING IN	OUTSIDE DOOR OPENING OUT

- Determine hand of lock required from hand of door chart above.
- All Lockwood 3570 Series Mortice Locks with Dual entry cylinders are mounted in accordance with these instructions. Disregard instructions referring to the features not required. Important : Before drilling door, ensure correct hand is being installed. NOTE: CASE DOES NOT need to be opened, to change HAND or FUNCTION of LOCK.

HANDING OF LOCK

- Determine hand of lock required from above hand of door chart.
- Rotate bolt head to suit latching direction.

1 PREPARE DOOR FOR LOCK

1. Establish height that lockset will be on door and mark centreline of door thickness on door edge.
2. Place template on door and align centreline on template with centreline on door. Mark and drill mortice.
3. Ease out mortice cavity where necessary.
4. Insert lock in mortice and scribe around front plate for size of recess. Remove lock from mortice and chisel recess 4mm deep to receive front and cover plate. Cover plate must be flush with edge of door.
5. ENSURE lock is removed from MORTICE cavity. Fold template and align EDGE A with bottom of coverplate recess. Establish holes required to suit lock furniture, mark hole centres LOCK accurately and drill holes.

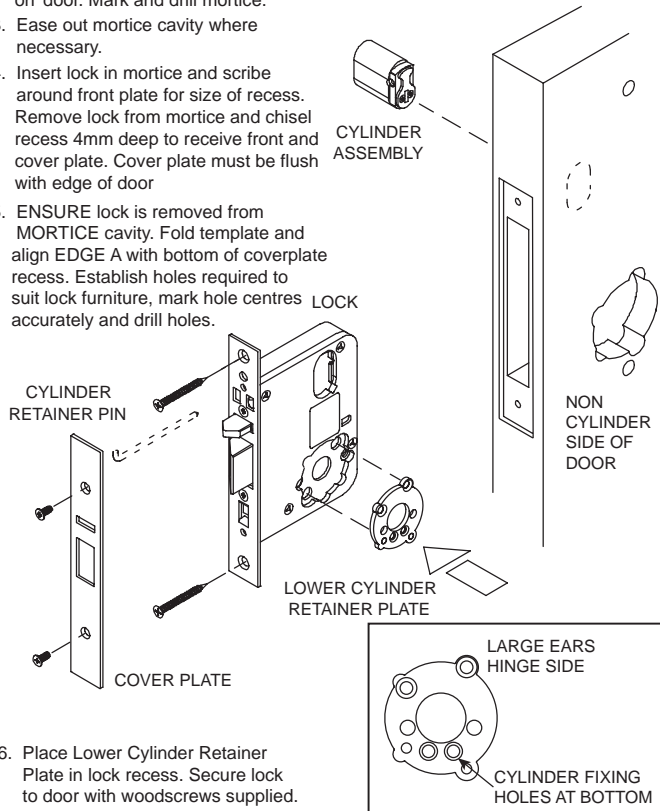

6. Place Lower Cylinder Retainer Plate in lock recess. Secure lock to door with woodscrews supplied.

2 MOUNTING OF UPPER CYLINDER

1. Using a small flat screwdriver, lever out Cylinder Hole Plug where fitted and insert Cylinder.
2. Secure Cylinder with Retainer Pin, ensuring pin is flush with front plate.
3. Install Cover plate and secure with 2 M4 screws to lock body.

3 MOUNTING OF LOWER CYLINDER

1. Assemble lower cylinder to mounting plate with 2 screws.
2. Install Lower Cylinder Assembly to lock and secure with screws supplied.

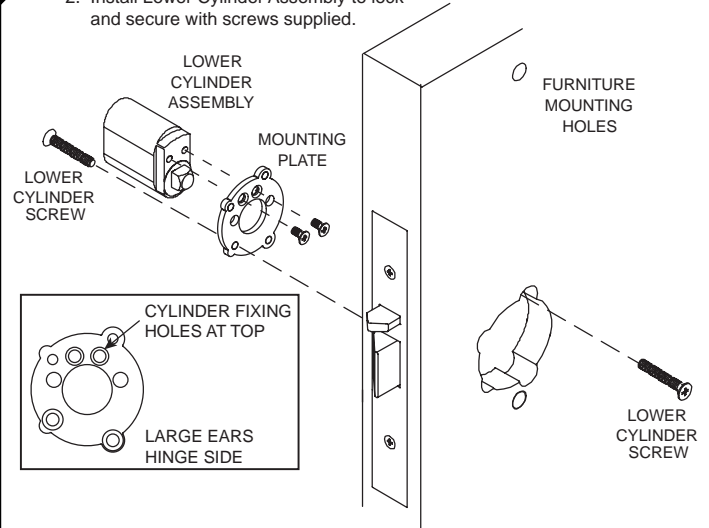

4 INSTALL FURNITURE

1. Attach door furniture with screws provided.
- NOTE : - For brass 1000 series, cut screws to length (Door thickness + 13mm)
- For aluminium 2000 series, screws supplied suit 35 - 45mm door thickness.
For doors 45 - 55mm order screws 2000-208

5 MOUNTING STRIKE

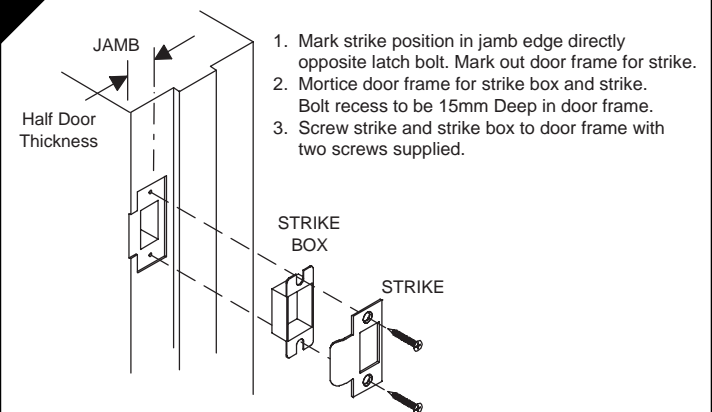

1. Mark strike position in jamb edge directly opposite latch bolt. Mark out door frame for strike.
2. Mortice door frame for strike box and strike. Bolt recess to be 15mm Deep in door frame.
3. Screw strike and strike box to door frame with two screws supplied.

3578 SERIES MORTICE LOCK MOUNTING INSTRUCTIONS

P/No. 3578-5121_30621_0506

HAND OF DOOR ACCORDING TO ENGLISH PRACTICE

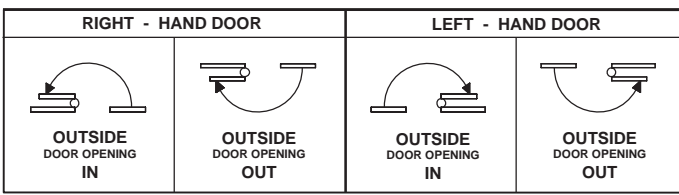

- Determine hand of lock required from hand of door chart above.
- All Lockwood 3578 Series Mortice Locks are mounted in accordance with these instructions. Locks may or may not have cylinders, lever handles, turn knob or emergency button. Disregard instructions referring to the features not required.
- Important : Before drilling door, ensure correct hand is being installed.
- NOTE: CASE DOES NOT need to be opened, to change HAND or FUNCTION of LOCK.

HANDING OF LOCK

- Determine hand of lock required from above hand of door chart.
- Rotate bolt head to suit latching direction.

1 SETTING LOCK STATUS

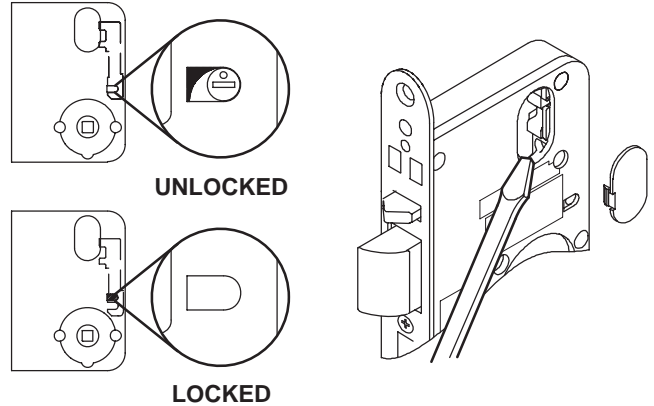

- Ensure lock is in UNLOCKED position.
- To UNLOCK (if required), using a small screwdriver, lever out Cylinder Hole Plug where fitted and lift snib using the screwdriver.

2 SETTING LOCK STATUS

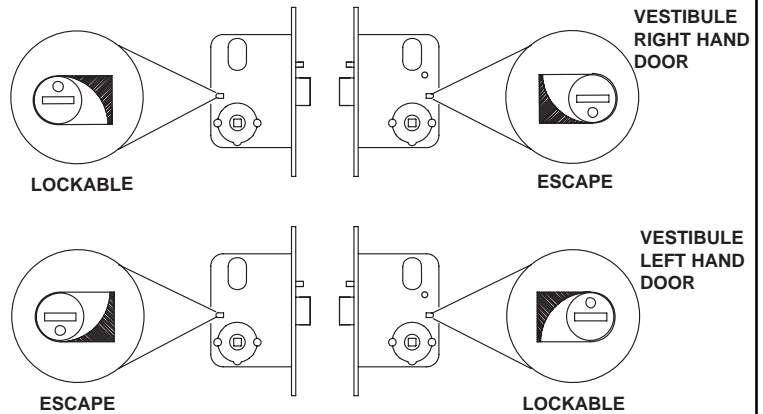
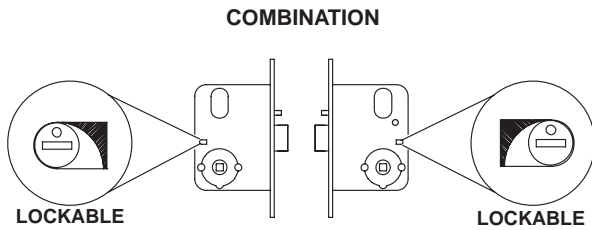

- **SNIB CAM**
Rotation of the Snib Cam hands the lock. Use a small screwdriver to rotate cam if required.
- **Combination locks**
(Both handles can be locked) DOT in the up position.

- **Vestibule Locks**
With single action escape feature. DOT to be DOWN on ESCAPE side and UP on LOCKABLE side.

3 TURN KNOB ADAPTORS

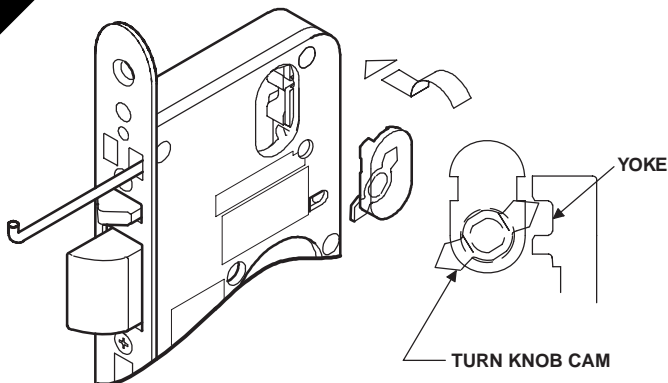

- Establish which side the adaptor is to be located, lever out Cylinder hole plug where fitted.
- **PUT LOCK IN LOCKED POSITION, as shown in Step 1.**
- Insert Adaptor into lock body with TOP of Turn Knob Cam point away from front of lock body. **Ensure Turn Knob Cam is engaged in yoke of snib as shown.**
- Place retainer pin through front plate to retain adaptor to lock. Ensure pin is flush with front plate

4 DOOR PREPARATION

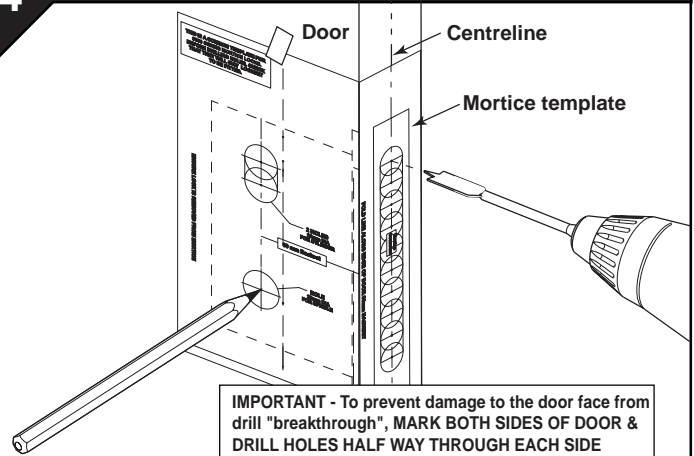

- Establish height that lockset will be mounted on door and mark centreline of door thickness on door edge.
- Place Mortise Template on door and align centreline on template with centreline on door. Secure with sticky tape.
- Mark and drill mortise to suit mortice lock depth (90mm).

3578 SERIES MORTICE LOCK MOUNTING INSTRUCTIONS

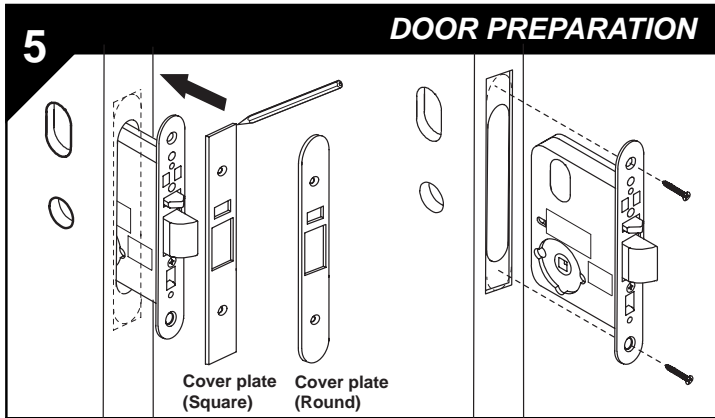

- Ease out mortise cavity where necessary. Clean out mortise before inserting lock.
- Insert lock in mortise with Cover Plate on and scribe around Cover Plate for size of recess, ensuring that no foreign matter finds its way into the lock mechanism.
- Remove lock from mortise and chisel recess 4mm deep to receive both front and cover plate. Cover plate must be flush with edge of door.
- Ensure lock is removed from mortise cavity. Fold template along backset fold line. Align EDGE A with bottom of cover plate recess. Establish holes required to suit lock function, mark hole centres accurately, drill and clean holes.
- Drill furniture holes as required.
- Fasten mortice lock into door using mounting screws provided.

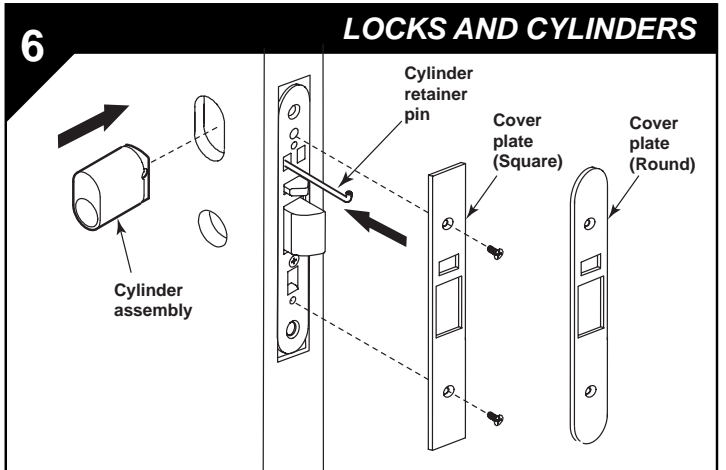

LOCKS WITH CYLINDERS

- Place lock in mortise and insert cylinder.
- Secure cylinder with retainer pin, ensuring pin is flush with front plate.
- Install Cover plate and secure with 2 M4 screws provided to lock body.

LOCKS WITHOUT CYLINDERS

- Install Cover plate and secure with 2 M4 screws provided to lock body.

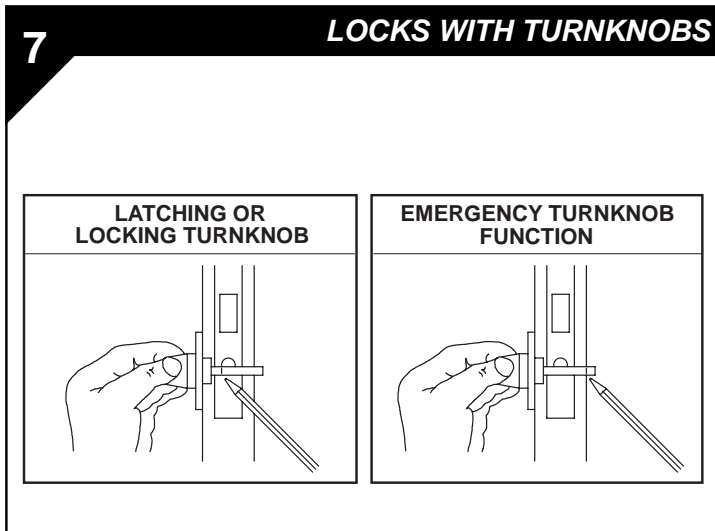

- Mark and cut connecting bar as shown.
- Turn knob to be in the vertical position when UNLOCKED.

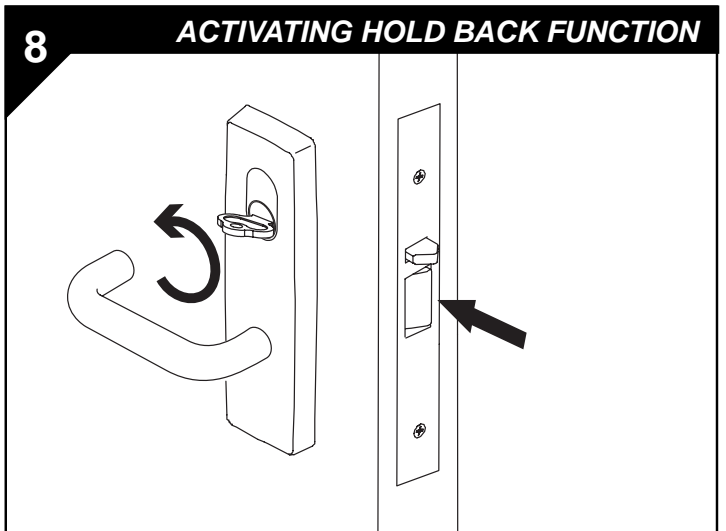

- To activate HOLD BACK function, depress latchbolt with thumb and turn key or turn knob.
- To de-activate HOLD BACK function turn key or turn knob in opposite direction.

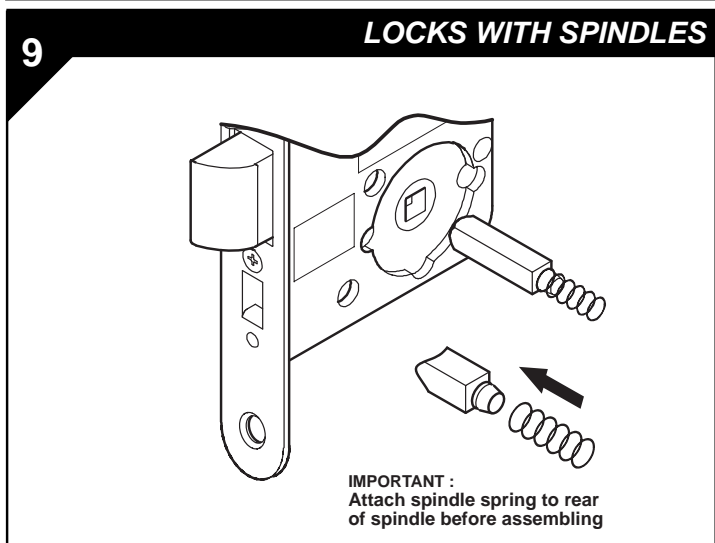

- All locks are supplied with spindles.
- Insert spindle(s) into lock, as required.
- Assemble furniture as required. Ensure furniture is not over-tightened.

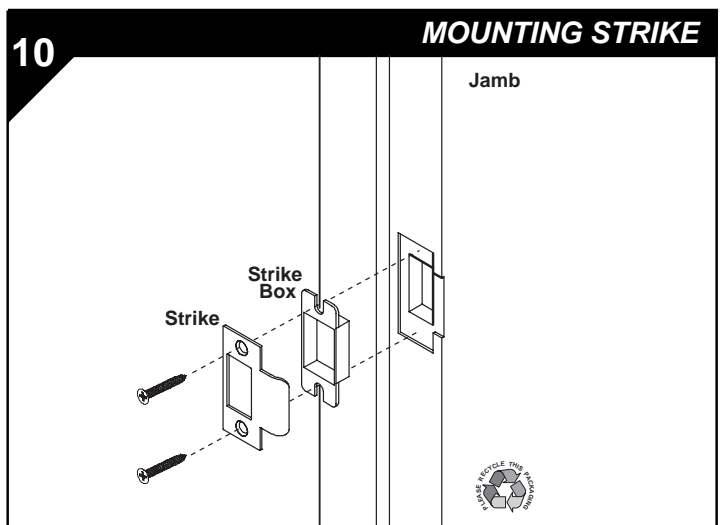

- Mark out door frame for strike.
- Mortise door frame for strike box and strike. Bolt recess to be 15mm deep in door frame.
- Screw strike and strike box to the door frame with two screws supplied with mortice lock.

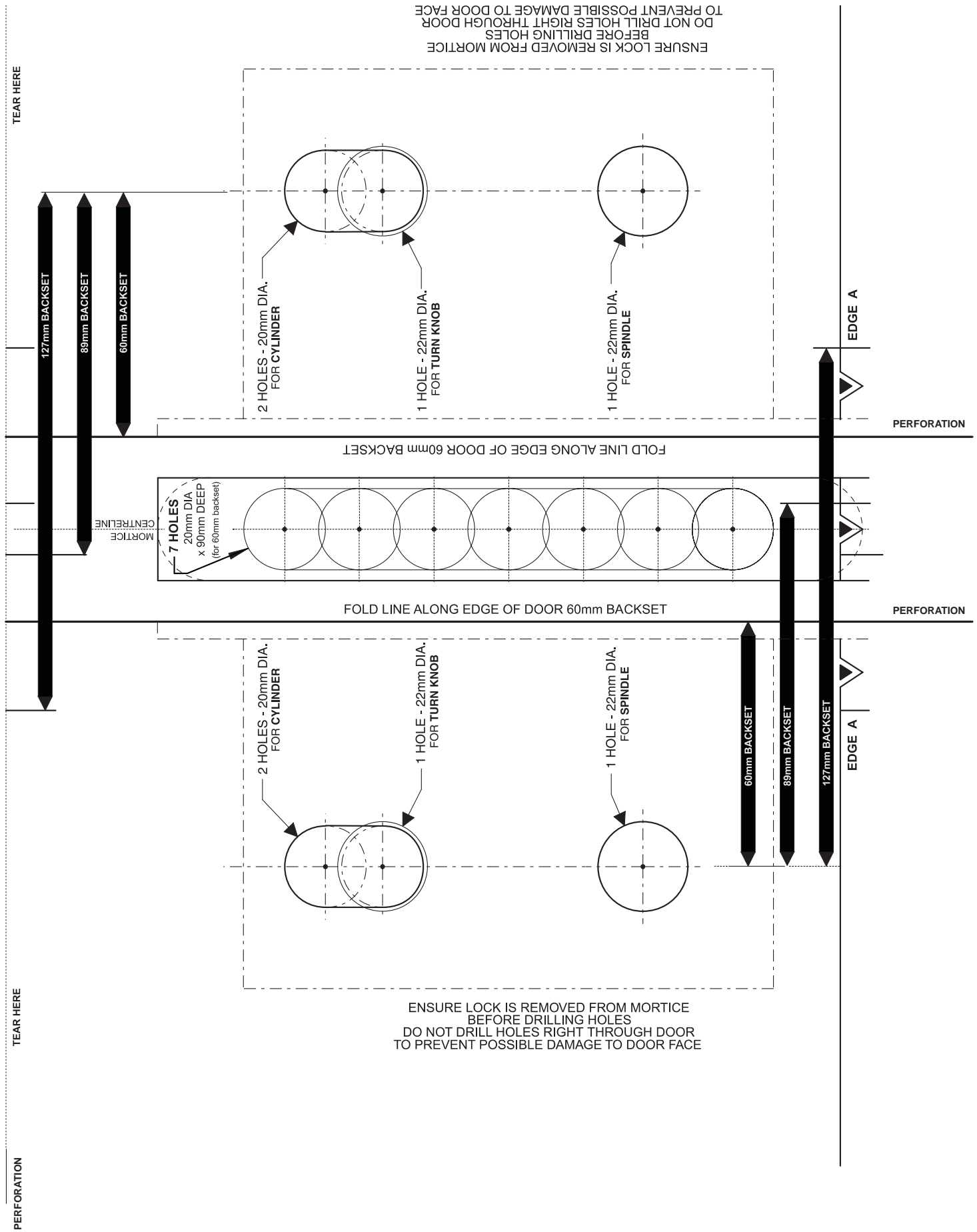

3578 SERIES MORTICE LOCK MOUNTING INSTRUCTIONS



3579 SERIES MORTICE LOCK MOUNTING INSTRUCTIONS

P/No. 3579-5121 30621 0609

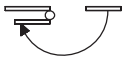
HAND OF DOOR ACCORDING TO ENGLISH PRACTICE

RIGHT - HAND DOOR		LEFT - HAND DOOR	
			
OUTSIDE DOOR OPENING IN	OUTSIDE DOOR OPENING OUT	OUTSIDE DOOR OPENING IN	OUTSIDE DOOR OPENING OUT

- Determine hand of lock required from hand of door chart above.
- All Lockwood 3579 Series Mortice Locks are mounted in accordance with these instructions. Locks may or may not have cylinders, lever handles, turn knob or emergency button. Disregard instructions referring to the features not required.
- Important : Before drilling door, ensure correct hand is being installed.
- NOTE: CASE DOES NOT need to be opened, to change HAND or FUNCTION of LOCK.

HANDING OF LOCK

- Determine hand of lock required from above hand of door chart.
- Rotate bolt head to suit latching direction.

1 SETTING LOCK STATUS

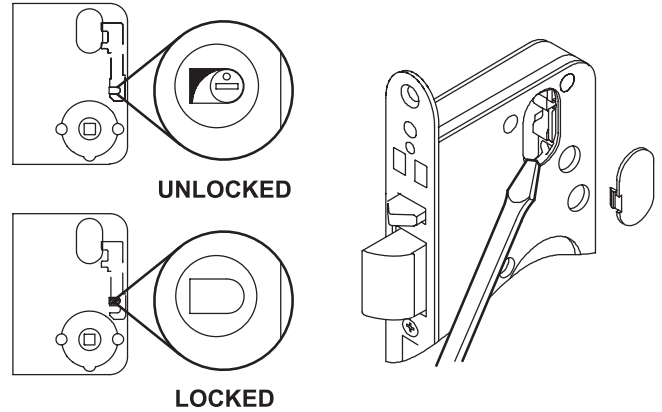

- Ensure lock is in UNLOCKED position.
- To UNLOCK (if required), using a small screwdriver, lever out Cylinder Hole Plug where fitted and lift snib using the screwdriver.

2 SETTING LOCK STATUS

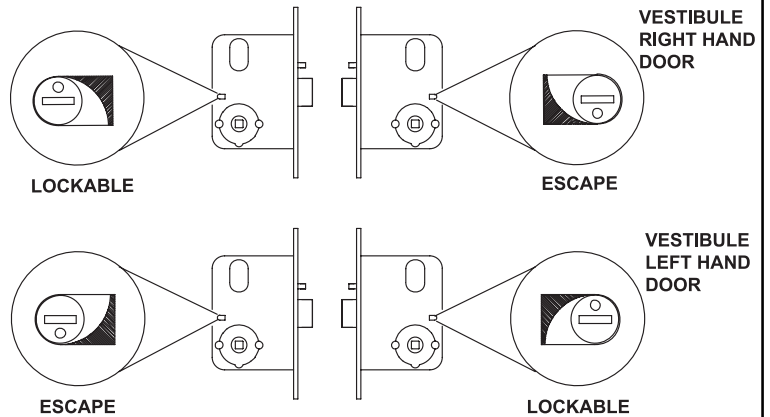
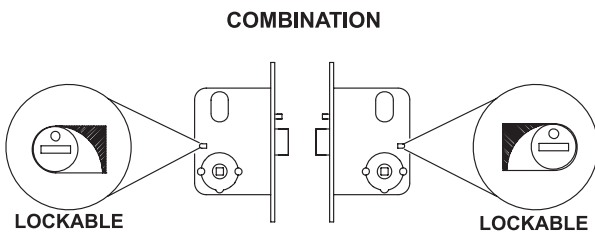

- **SNIB CAM**
Rotation of the Snib Cam hands the lock. Use a small screwdriver to rotate cam if required.
- **Combination locks**
(Both handles can be locked) DOT in the up position.

- **Vestibule Locks**
With single action escape feature. DOT to be DOWN on ESCAPE side and UP on LOCKABLE side.

3 SETTING KICK-OFF FUNCTION

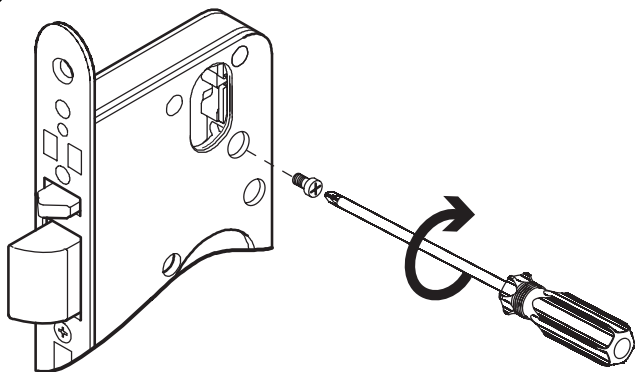

- To de-activate KICK-OFF function, ensure the lock is unlocked, then remove the KICK-OFF screw as shown. Rotate screw in the direction of the arrow as the screw is left hand thread.

4 TURN KNOB ADAPTORS

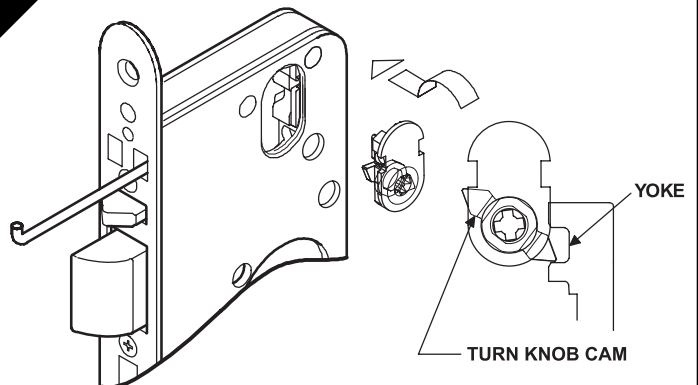

- Establish which side the adaptor is to be located, lever out Cylinder hole plug where fitted.
- **PUT LOCK IN LOCKED POSITION, as shown in Step 1.**
- Insert Adaptor into lock body with TOP of Turn Knob Cam point away from front of lock body. **Ensure Turn Knob Cam is engaged in yoke of snib as shown.**
- Place retainer pin through front plate to retain adaptor to lock. Ensure pin is flush with front plate

3579 SERIES MORTICE LOCK MOUNTING INSTRUCTIONS

5 DOOR PREPARATION

IMPORTANT - To prevent damage to the door face from drill "breakthrough", MARK BOTH SIDES OF DOOR & DRILL HOLES HALF WAY THROUGH EACH SIDE

- Establish height that lockset will be mounted on door and mark centreline of door thickness on door edge.
- Place Mortise Template on door and align centreline on template with centreline on door. Secure with sticky tape.
- Mark and drill mortise to suit mortise lock depth (90mm).

6 DOOR PREPARATION

- Ease out mortise cavity where necessary. Clean out mortise before inserting lock.
- Insert lock in mortise with Cover Plate on and scribe around Cover Plate for size of recess, ensuring that no foreign matter finds its way into the lock mechanism.
- Remove lock from mortise and chisel recess 4mm deep to receive both front and cover plate. Cover plate must be flush with edge of door.
- Ensure lock is removed from mortise cavity. Fold template along backset fold line. Align EDGE A with bottom of cover plate recess. Establish holes required to suit lock function, mark hole centres accurately, drill and clean holes.
- Drill furniture holes as required.
- Fasten mortise lock into door using mounting screws provided.

7 LOCKS AND CYLINDERS

LOCKS WITH CYLINDERS

- Place lock in mortise and insert cylinder.
- Secure cylinder with retainer pin, ensuring pin is flush with front plate.
- Install Cover plate and secure with 2 M4 screws provided to lock body.

LOCKS WITHOUT CYLINDERS

- Install Cover plate and secure with 2 M4 screws provided to lock body.

8 LOCKS WITH TURNKNOBS

LATCHING OR LOCKING TURNKNOB

EMERGENCY TURNKNOB FUNCTION

- Mark and cut connecting bar as shown.
- Turn knob to be in the vertical position when UNLOCKED.

9 LOCKS WITH SPINDLES

IMPORTANT: Attach spindle spring to rear of spindle before assembling

- All locks are supplied with spindles.
- Insert spindle(s) into lock, as required.
- Assemble furniture as required. Ensure furniture is not over-tightened.

10 MOUNTING STRIKE

- Mark out door frame for strike.
- Mortise door frame for strike box and strike. Bolt recess to be 15mm deep in door frame.
- Screw strike and strike box to the door frame with two screws supplied with mortise lock.

3579 SERIES MORTICE LOCK MOUNTING INSTRUCTIONS

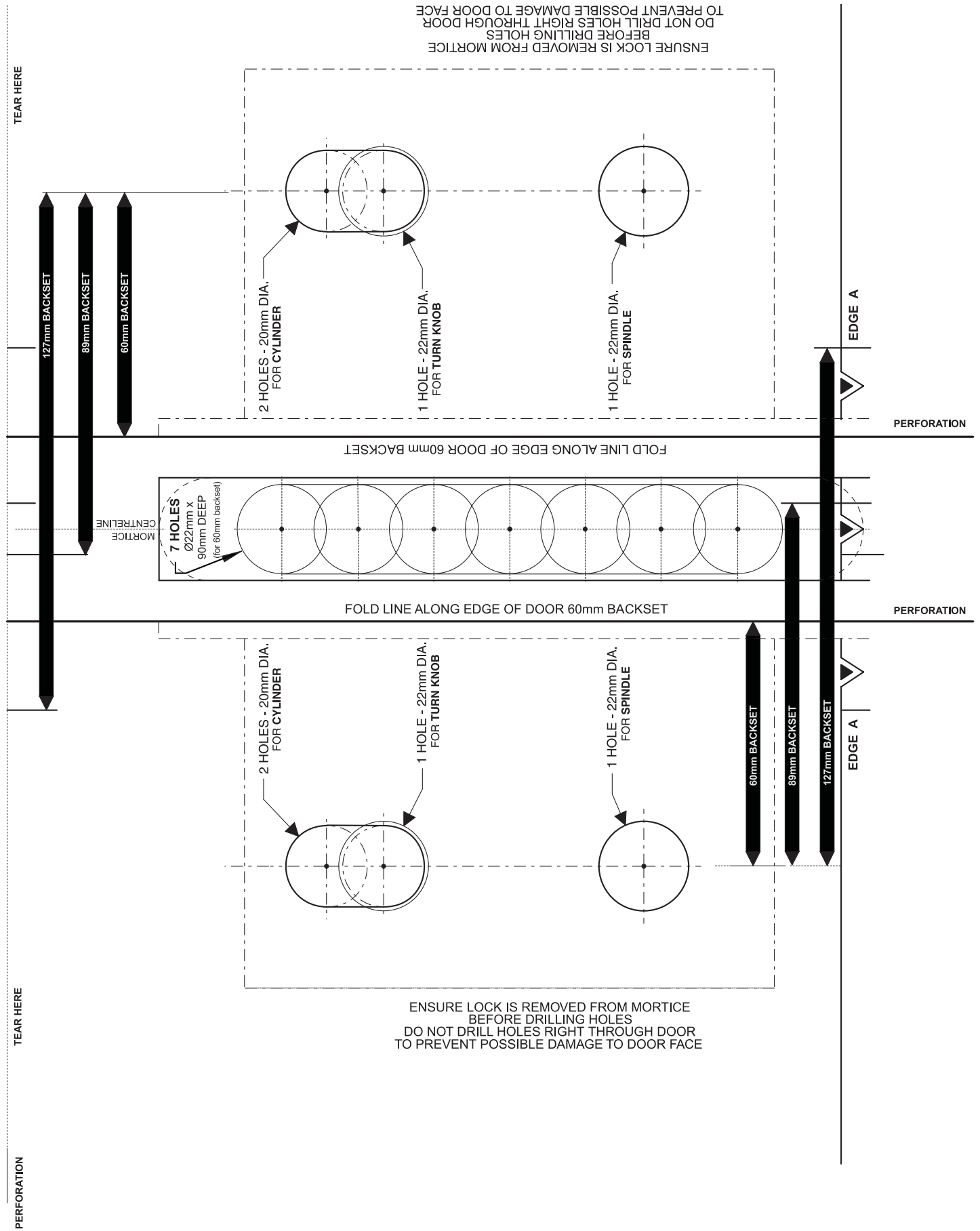

3570 SERIES REBATE MORTICE LOCKS MOUNTING INSTRUCTIONS

P/No. 3870-5221
30621 0312

All Lockwood 3P70 Series Rebate Mortice Lock Kits are to be mounted in accordance with this instruction and in conjunction with the standard instructions supplied with the LOCK.

MORTICE INSTRUCTION

1. Place LOCK instruction template on door. Mark and drill mortice to desired BACKSET depth.
2. Ease out mortice where necessary.
3. Place lock through SPACER and insert lock in mortice, scribe around spacer for size of recess. Remove lock from mortice and chisel out recess to receive spacer. Faceplate must be flush with protruding edge of door.

MOUNTING STRIKE

1. Mark out door frame for strike.
2. Mortice door frame for strike.
N.B. Strike to be flush with face of frame. Bolt recess to be 15mm deep in door frame.
3. Screw Strike to door frame with woodscrews provided.

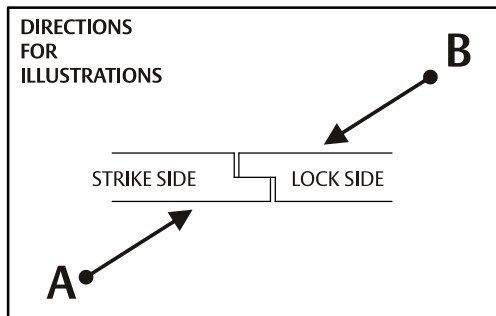

Various Strikes for Rebate Kits

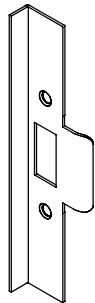
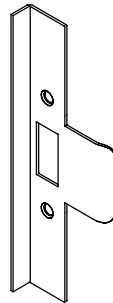
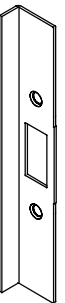
LATCHING REBATE 3P72-RK32	LATCHING REBATE 3P72-RK46	LATCHING REBATE 3571-2902
		
32mm Lip Strike	46mm Lip Strike	Lipless Strike

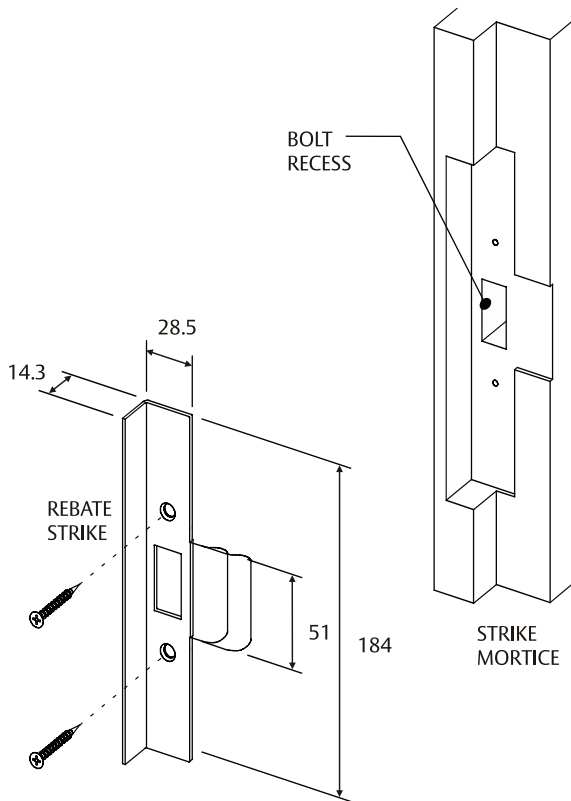

LOCK MORTICE VIEWED IN DIRECTION OF ARROW 'B'

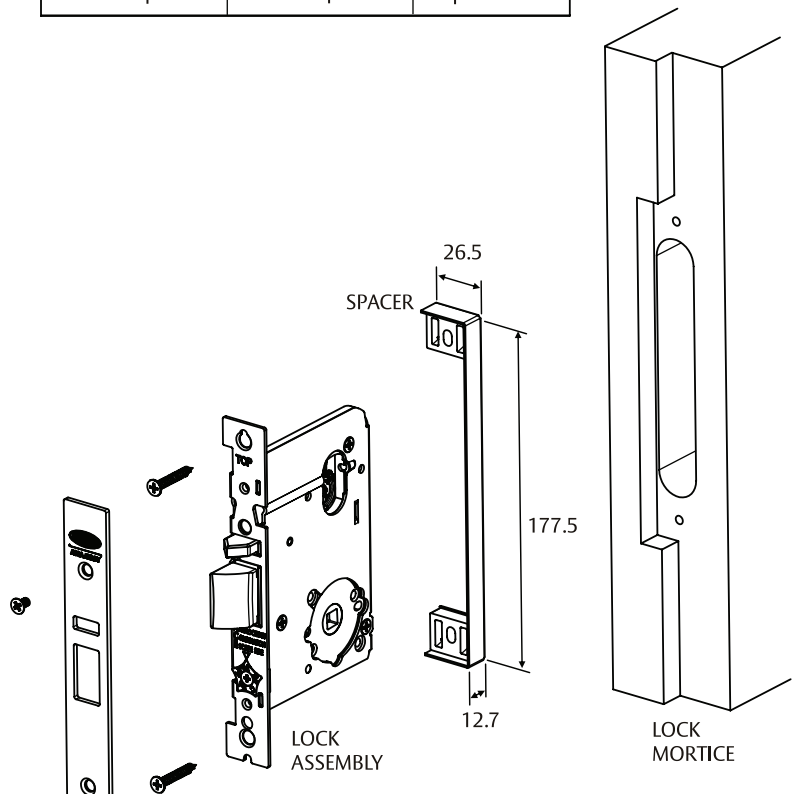

FACEPLATE

LOCK MORTICE VIEWED IN DIRECTION OF ARROW 'A'

DEADLOCK ASSEMBLIES NOT ILLUSTRATED

3580 SHORT BACKSET MORTICE LOCK MOUNTING INSTRUCTIONS

3580-121
30621 0508

HAND OF DOOR ACCORDING TO ENGLISH PRACTICE			
RIGHT - HAND DOOR		LEFT - HAND DOOR	
OUTSIDE DOOR OPENING IN	OUTSIDE DOOR OPENING OUT	OUTSIDE DOOR OPENING IN	OUTSIDE DOOR OPENING OUT

All Lockwood 3580 Series Mortice Locks are mounted in accordance with these instructions. Locks may or may not have cylinders, lever handles, turn knob or emergency button. Disregard instructions referring to the features not required.

Please Note: the 3582EA Series mortice lock has an auto kick-off function. Important: Before drilling door, ensure correct hand is being installed.

PREPARE DOOR FOR LOCK

1. Establish height that lockset will be on door.
2. Cut COVER PLATE window 156mm x 25.4mm with 3mm radii.
3. Place template in opening and drill 2 holes 4.5mm Dia and countersink 8.5mm Dia x 90°.

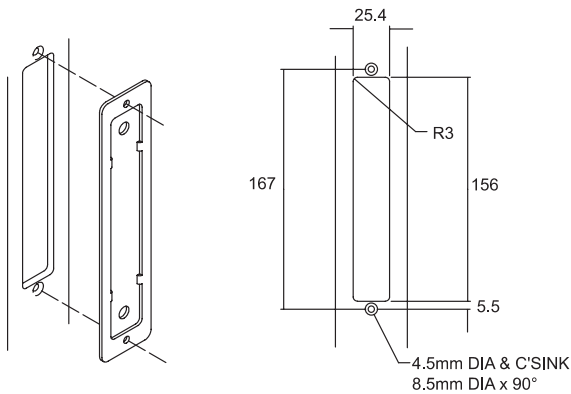

4. ENSURE lock is removed from cavity. Drill appropriate holes to suit lockset. Dimensions shown suit all functions of this series of locksets. Note: 23mm Backset shown (standard), others include 25.4mm, 30mm and 38mm.

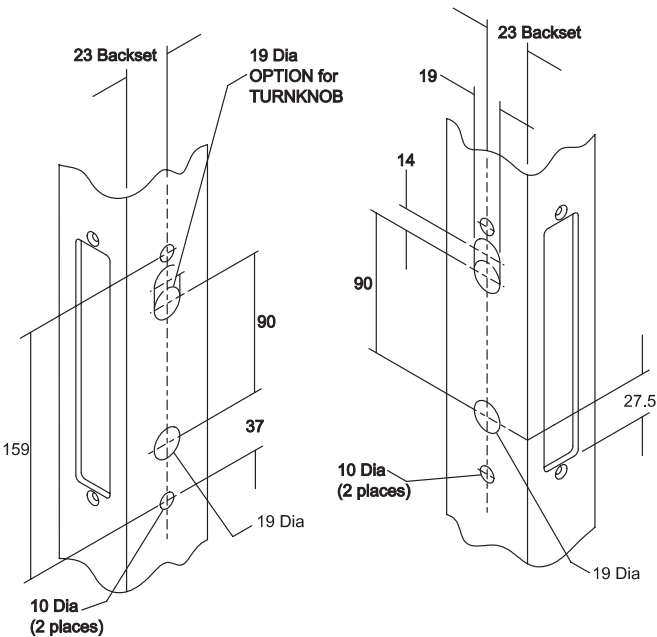

LOCK STATUS

1. Ensure Locking Snib is in the unlocked position (UP).
2. To unlock (if required): Using a small flat screwdriver, lever out Cylinder Hole Plug where fitted and lift snib using the screwdriver.

Vestibule Locks

With single action Escape feature, the **SCREW** should be in the **UP** position on the Escape side and in the **DOWN** position on the lockable side.

Combination Locks

(Both handles can be locked) both **SCREWS** should be in the **DOWN** position.

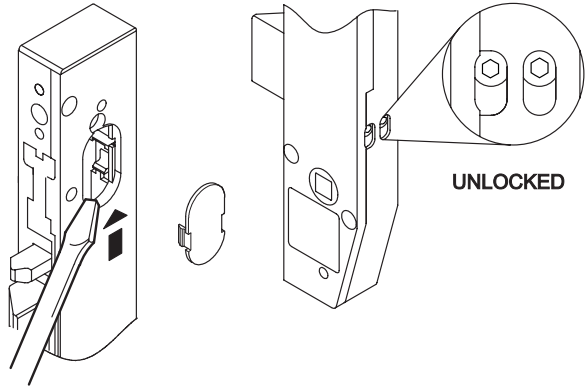

VESTIBULE

COMBINATION

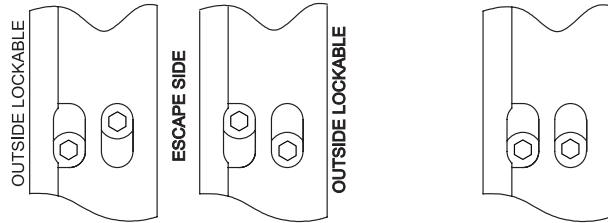

LH DOOR RH DOOR

TO CHANGE LOCK STATUS :

Loosen screw approximately 3 Full Turns. Slide screw to appropriate position and tighten firmly.

REVERSE BOLT

BEFORE INSTALLING IN DOOR

1. Determine hand of lock from hand of door chart.
2. Rotate bolt head to suit latching direction.

EXTENDED BACKSETS

1. Remove Extension packer by removing the 2 screws.
2. Rotate bolt head to suit latching direction.
3. Re-attach Extension Packer with the 2 screws.

TURN KNOB ADAPTOR

1. Establish side that adaptor is to be located, lever out Cylinder Hole Plug using a small flat screwdriver.
2. Using the small screwdriver set the Locking snib into the Locked condition. Insert Adaptor into lock with TOP of Butterfly Lever pointing towards the front of lock body. (Butterfly Lever to be engaged in yoke of snib) as shown in diagram.
3. Place Retainer pin through front plate to retain adaptor in lock. Ensure retainer pin is flush with front face of lock.

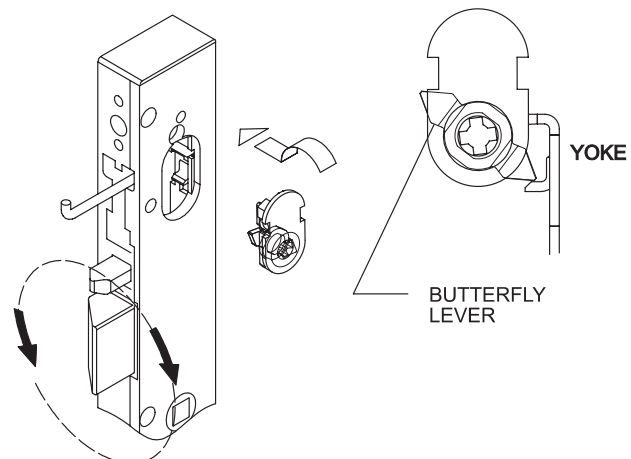

3580 SHORT BACKSET MORTICE LOCK MOUNTING INSTRUCTIONS

FIT LOCK TO DOOR

1. Insert lock into door and secure with 2 screws.

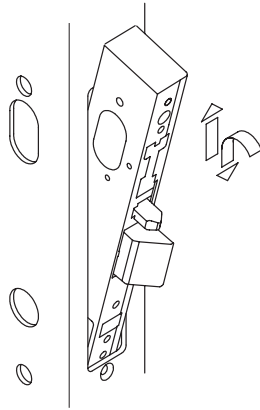

LOCKS WITH CYLINDER

1. Using a small flat screwdriver, lever out Cylinder Hole Plug where fitted. Insert lock into door and secure with 2 screws.
2. Secure cylinder with Retainer pin, ensuring pin is flush with front face of lock.
3. Install cover plate and secure with 2 screws.

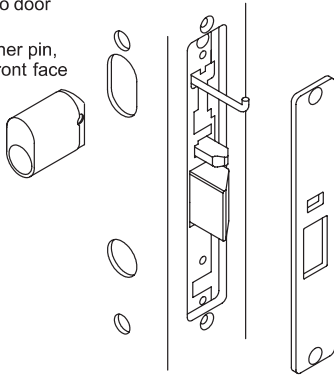

LOCKS WITHOUT CYLINDER

1. Install cover plate and secure with 2 screws.

LOCKS WITH TURNKNOB

1. Mark and cut connecting bar as shown.
2. Turnknob to be in vertical position when UNLOCKED.

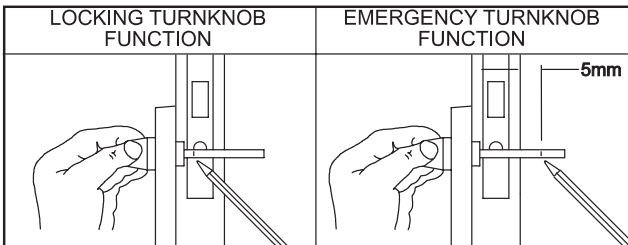

LOCKS WITH SPINDLE

1. All locks are supplied with spindles.
2. Insert spindle(s) into lock, as required.

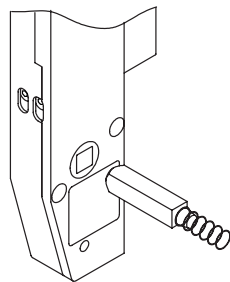
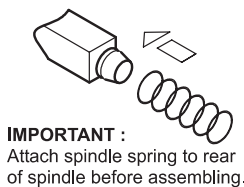

INSTALL FURNITURE

1. Determine hand of furniture required.
2. Rotate handle to the desired hand as shown.
3. For THINNER doors (44mm or less) CUT the furniture screws 5mm past the door face as shown.
4. Position Furniture plates and secure with mounting screws.

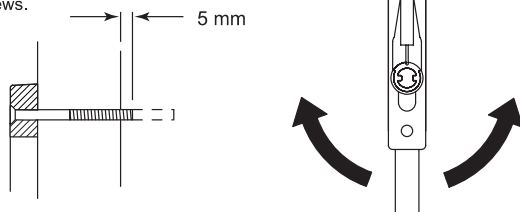

MOUNTING STRIKE

1. Prepare door jamb Cutout.
2. Fit strike box to frame and secure with 2 screws.
3. Fit strike to strike box and secure with 2 screws.

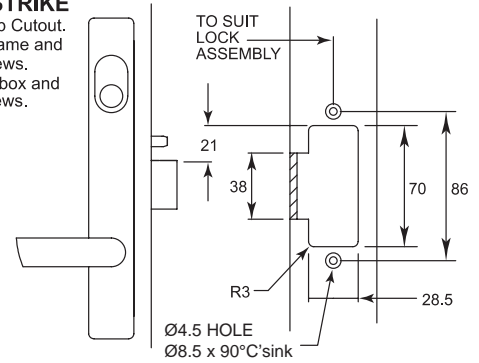

RETROFIT STRIKE

1. Prepare door jamb.
2. Attach Mounting plates to jamb with 2 screws.
3. Fit strike box to strike with 2 screws.
4. Fit and secure strike to Mounting plates with 2 screws.

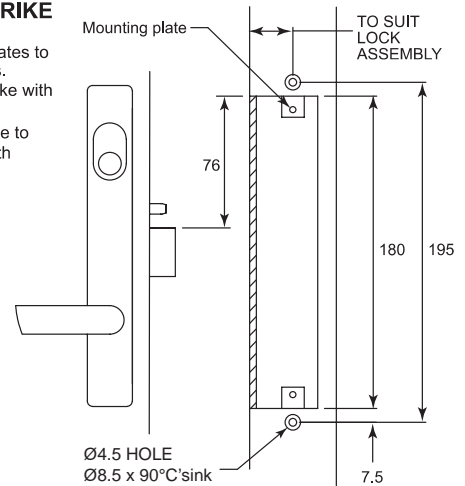

3590 SERIES MORTICE LOCKS MOUNTING INSTRUCTIONS

3580-21
30621 1210

HAND OF DOOR ACCORDING TO ENGLISH PRACTICE			
RIGHT - HAND DOOR		LEFT - HAND DOOR	
OUTSIDE DOOR OPENING IN	OUTSIDE DOOR OPENING OUT	OUTSIDE DOOR OPENING IN	OUTSIDE DOOR OPENING OUT

All Lockwood 3580 Series Mortice Locks are mounted in accordance with these instructions. Locks may or may not have cylinders, lever handles, turn knob or emergency button. Disregard instructions referring to the features not required.
Please Note: the 3582EA Series mortice lock has an auto kick-off function.
Important : Before drilling door, ensure correct hand is being installed.

LOCK STATUS

1. Ensure Locking Snib is in the unlocked position (UP).
2. To unlock (if required) :
Using a small flat screwdriver, lever out Cylinder Hole Plug where fitted and lift snib using the screwdriver.

Vestibule Locks

With single action Escape feature, the **SCREW** should be in the **UP** position on the Escape side and in the **DOWN** position on the lockable side.

Combination Locks

(Both handles can be locked) both **SCREWS** should be in the **DOWN** position.

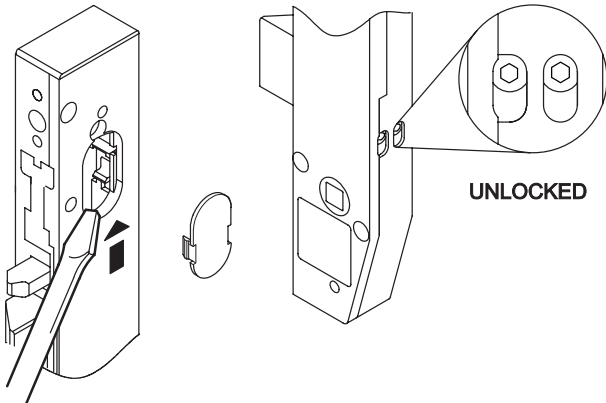

VESTIBULE

COMBINATION

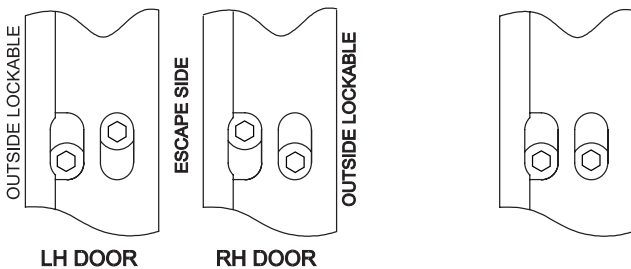

TO CHANGE LOCK STATUS :

Loosen screw approximately 3 Full Turns. Slide screw to appropriate position and tighten firmly.

REVERSE BOLT

BEFORE INSTALLING IN DOOR

1. Determine hand of lock from hand of door chart.
2. Rotate bolt head to suit latching direction.

EXTENDED BACKSETS

1. Remove Extension packer by removing the 2 screws.
2. Rotate bolt head to suit latching direction.
3. Re-attach Extension Packer with the 2 screws.

TURN KNOB ADAPTOR

1. Establish side that Adaptor is to be located, lever out Cylinder Hole Plug where fitted with a small flat screwdriver.
2. Using the small screwdriver set the Locking snib into the Locked condition. Insert Adaptor into lock, with TOP of Butterfly Lever pointing towards the front of lock body.
(Butterfly Lever to be engaged in yoke of snib) as shown.
3. Place Retainer pin through front plate to retain adaptor in lock. Ensure pin is flush with front face of lock.

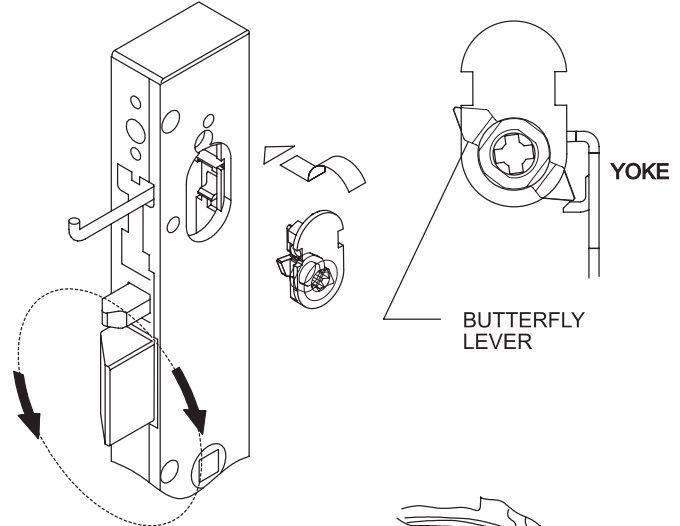

MORTICE INSTRUCTIONS

1. Establish height that lockset will be on door and mark centreline of door thickness on door edge.
2. Place template on door and align centreline on template with centreline on door. Mark and drill mortice to desired backset depth.
3. Ease out mortice cavity where necessary.
4. Attach cover plate to lock with 2 M4 screws and insert lock in the mortice and scribe around cover plate for size of recess. Remove lock from mortice and Chisel 3mm deep to receive cover plate. Cover plate must be flush with edge of door. Remove cover plate from lock.
(if Cylinders are to be fitted).
5. **ENSURE** lock is removed from MORTICE cavity. Fold template to desired BACKSET depth. Align **EDGE A** with bottom of cover plate recess. Establish holes required to suit lock function, mark hole centres accurately, drill and clean holes.

IMPORTANT
MARK BOTH SIDES OF DOOR.
DO NOT DRILL RIGHT THROUGH DOOR FROM ONE SIDE.

To prevent damage to door face from drill " breakthrough "

LOCKS WITH CYLINDER

1. Using a small flat screwdriver, lever out Cylinder Hole Plug where fitted.
Place lock in mortice and insert Cylinder.
2. Secure Cylinder with Retainer pin, ensuring pin is flush with front face of lock.
3. Install Cover plate and secure with 2 M4 screws to lock body. Secure lock to door with 2 woodscrews supplied.

LOCKS WITHOUT CYLINDER

1. Secure lock to door with 2 woodscrews supplied.

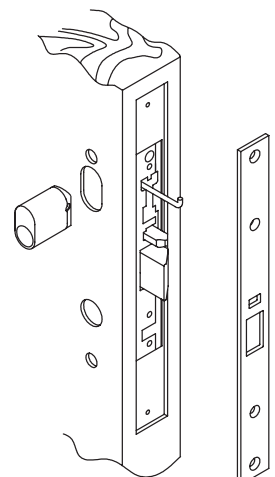

3590 SERIES MORTICE LOCK MOUNTING INSTRUCTIONS

LOCKS WITH TURNKNOB

1. Mark and cut connecting bar as shown.
2. Turnknob to be in vertical position when UNLOCKED.

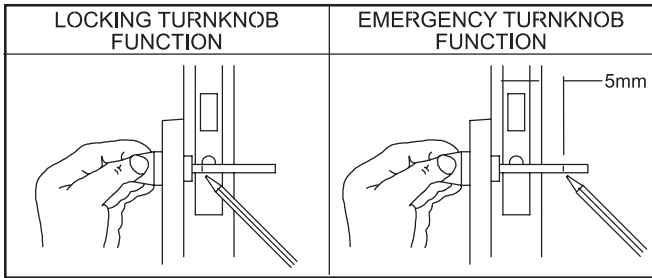

INSTALL FURNITURE

1. Determine hand of furniture required.
2. Rotate handle to the desired hand as shown.
3. For THINNER doors (44mm or less) CUT the furniture screws 5mm past the door face as shown.
4. Position Furniture plates and secure with mounting screws.

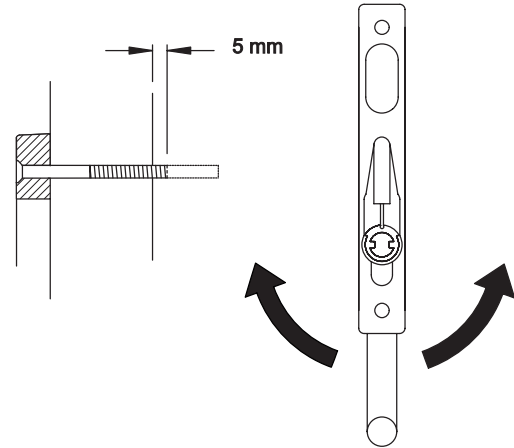

LOCKS WITH SPINDLES

1. All locks are supplied with spindles.
2. Insert spindle(s) into lock hubs, as required.

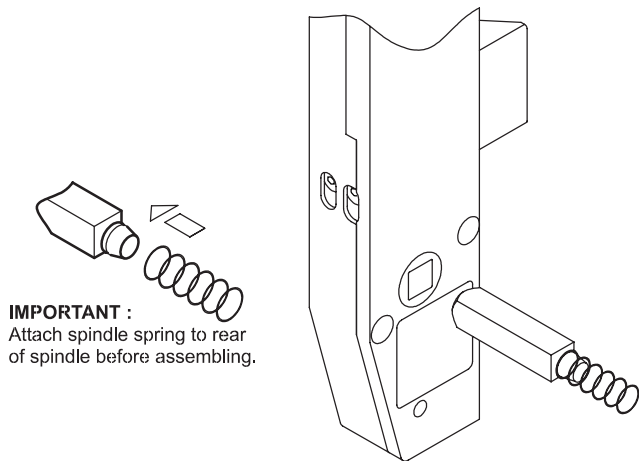

MOUNTING STRIKE

1. Mark out door frame for strike.
2. Mortice door frame for strike box and strike.
NB : Strike to be flush with face of frame.
Bolt recess to be 15mm Deep in door frame.
3. Screw strike and strike box to the door frame with 2 woodscrews supplied.

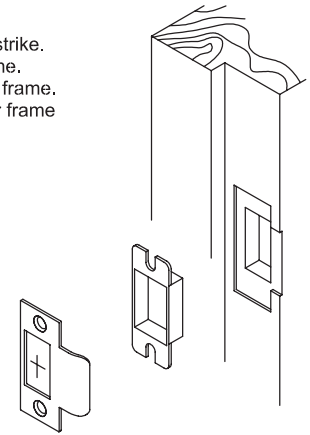

3590 SERIES MORTICE LOCK MOUNTING INSTRUCTIONS

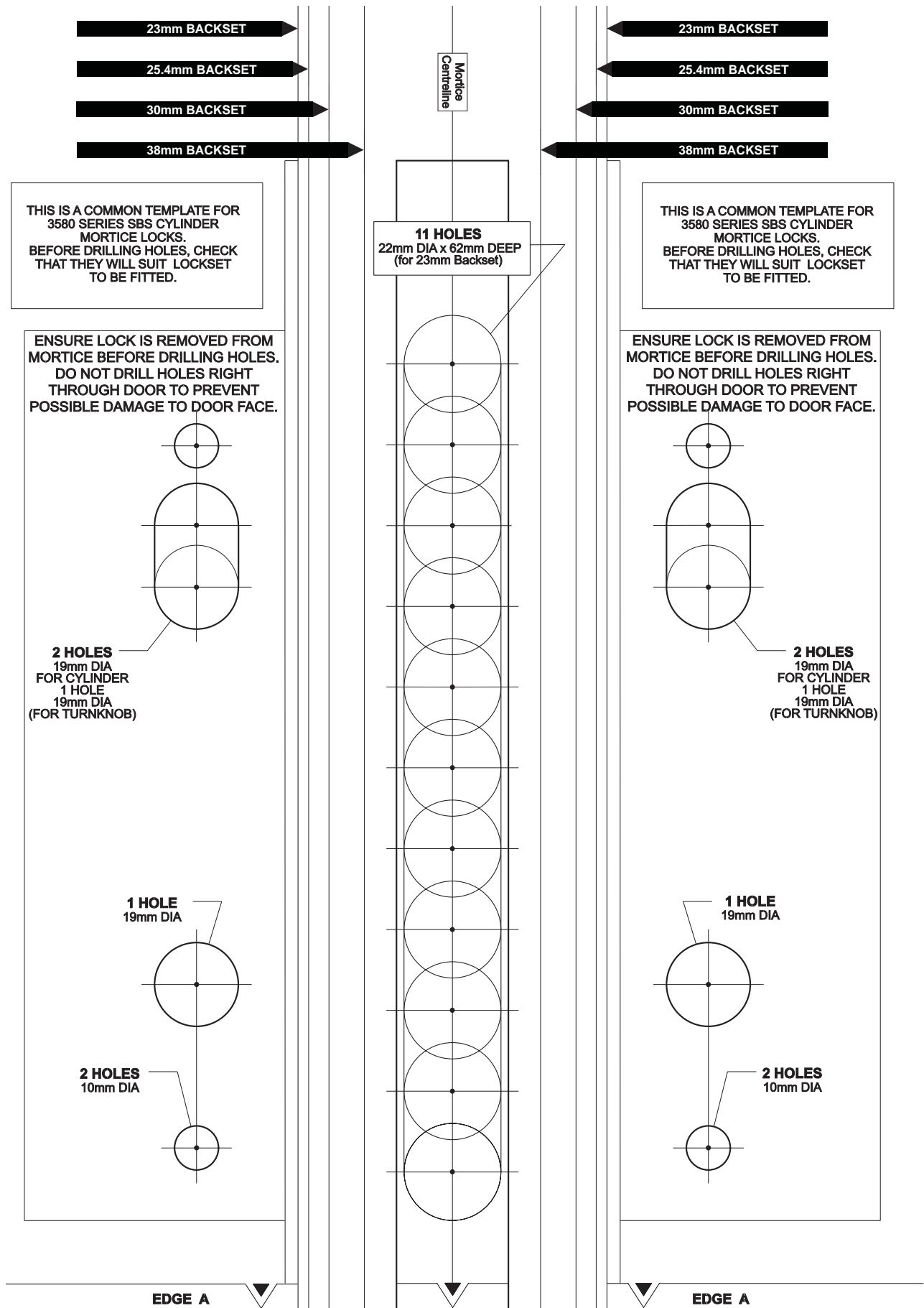

3580 SERIES REBATE MORTICE LOCKS

MOUNTING INSTRUCTIONS

3580-421
0212

IMPORTANT : REBATE KITS SUIT 30mm and 38mm BACKSETS ONLY.

All Lockwood 3580 Series Short Backset Rebate Mortice Lock Kits are to be mounted in accordance with this instruction and in conjunction with the standard instructions supplied with the LOCK.

MORTICE INSTRUCTIONS

1. Place **LOCK** instruction template on door. Mark and drill lock mortice to desired backset depth.
2. Ease out mortice where necessary.
3. Place lock through **SPACER** and insert lock in mortice, scribe around Spacer for size of recess. Remove lock from mortice and chisel recess to receive spacer. Coverplate must be flush with protruding edge of door.

MOUNTING STRIKE

1. Mark out door frame for strike.
2. Mortice door frame for strike.
NB :Strike to be flush with face of frame. Bolt recess to be 15mm deep in door frame.

ELECTRIC REBATE

Counterbore 25mm Dia hole x 2mm deep (max) and drill 19mm Dia hole, 78mm below strike centre line.

3. Insert Magnet in hole.

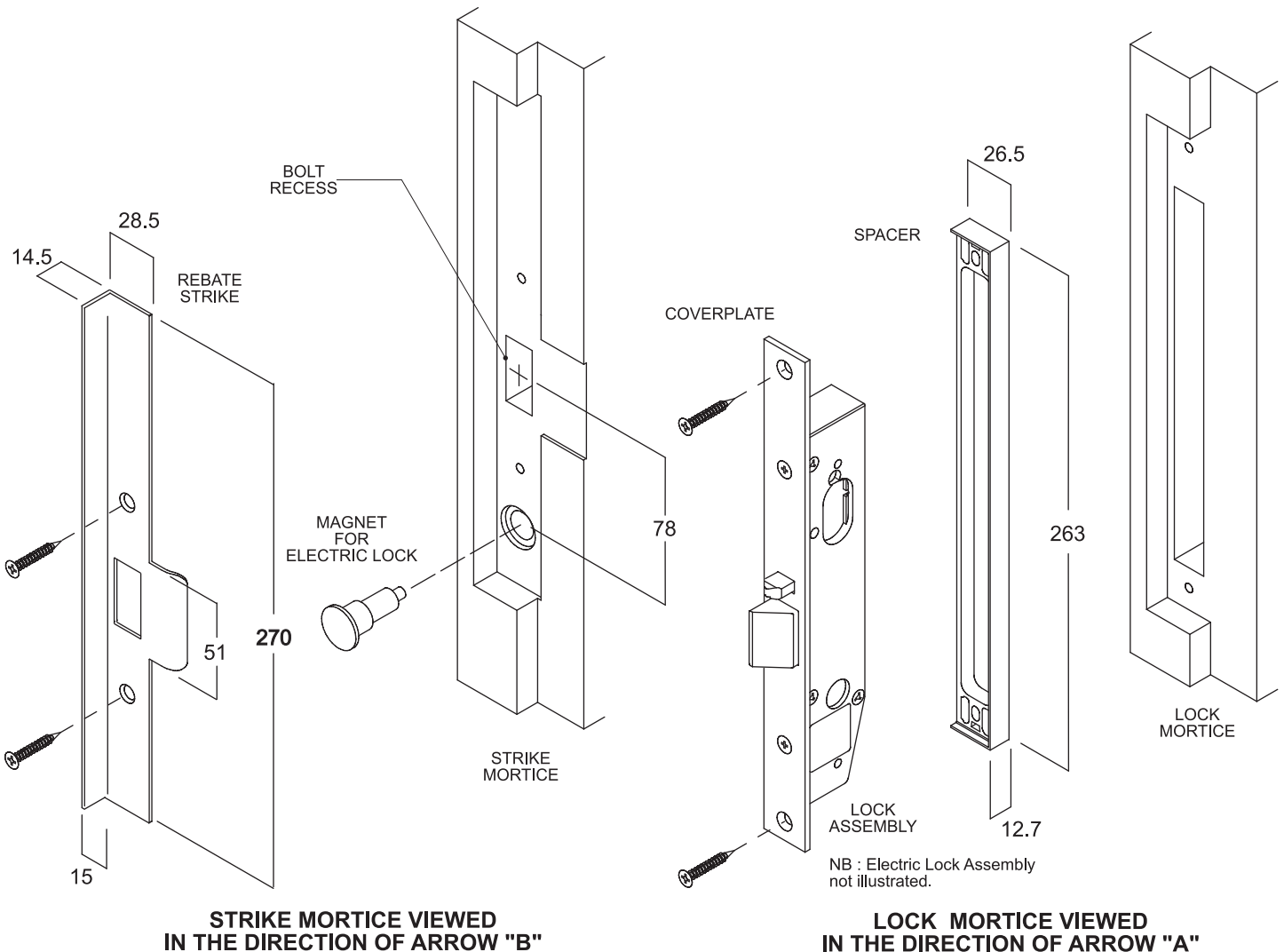
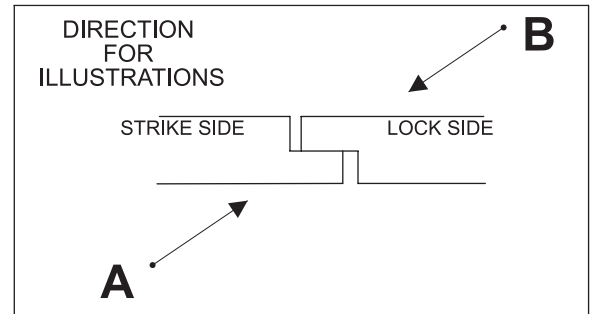

Disclaimer

Whilst every effort has been made to ensure that the information contained in this manual is accurate at the time of publication, ASSA ABLOY Australia Pty Limited ("ASSA ABLOY") recommends that you consult ASSA ABLOY or its agents prior to placing an order to ascertain current information on specific products, as ASSA ABLOY reserves the right to make changes without notice. ASSA ABLOY will not be liable for any injury, loss or damage whatsoever, arising from any errors or omissions in the information contained in the manual or arising from the use or application of the information contained herein.

© 2012 copyright by ASSA ABLOY All rights reserved



ASSA ABLOY



Lockwood is the leading brand in the Australian locking industry. With an established reputation for high quality products, this iconic brand provides a wide range of locking solutions to residential housing, commercial building and industrial application markets. Lockwood is supported by an extensive distribution and after-sales support network. Our customers include retailers, architects, trade and industrial personnel, locksmiths and security dealers.

ASSA ABLOY

ASSA ABLOY is the global leader in door opening solutions, dedicated to satisfying end-user needs for security, safety and convenience.

ASSA ABLOY is represented in all major regions, in both mature and emerging markets, with leading positions in Australia, Europe and North America.

As the world's leading lock group, ASSA ABLOY offers a more complete product range of door opening solutions than any other company in the market.

ASSA ABLOY Australia Pty Ltd
235 Huntingdale Road
Oakleigh, Victoria, 3166
Australia

1300 LOCK UP (1300 562 587)
lockweb.com.au

ASSA ABLOY New Zealand Ltd
6 Armstrong Road
Albany, North Shore City, 0632
New Zealand

info.nz@assaabloy.com
Telephone +64 9415 7111
assaabloy.co.nz

