



# 3540 SERIES MORTICE DEADLOCK

With FABRICATOR COVER PLATE for METAL DOORS

P/No. 3540-221 30621 0208

## 1 PREPARING DOOR

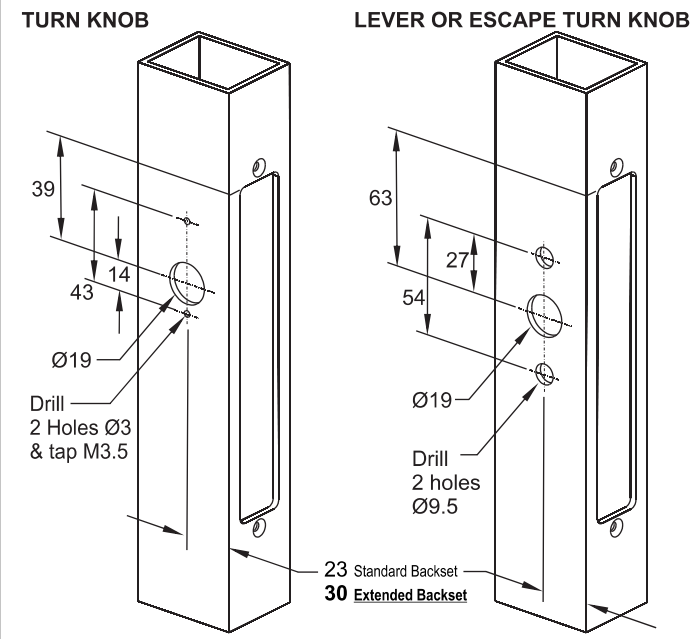
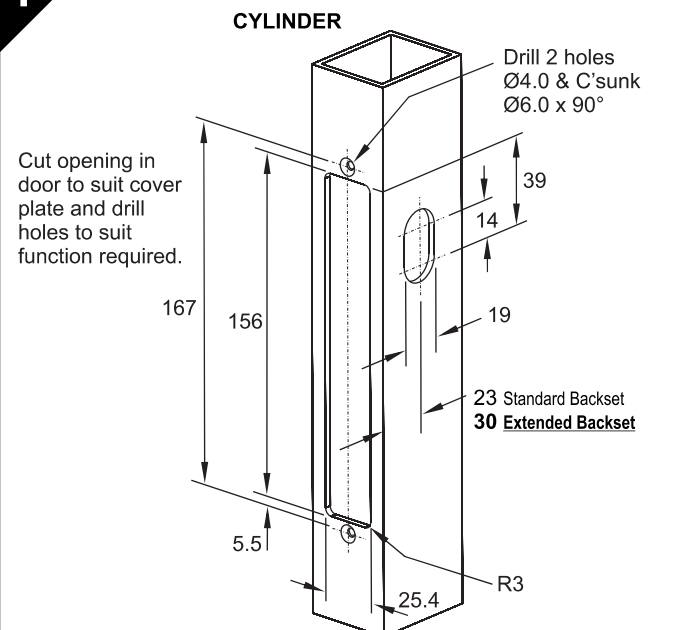

## 2 FITTING ADAPTORS

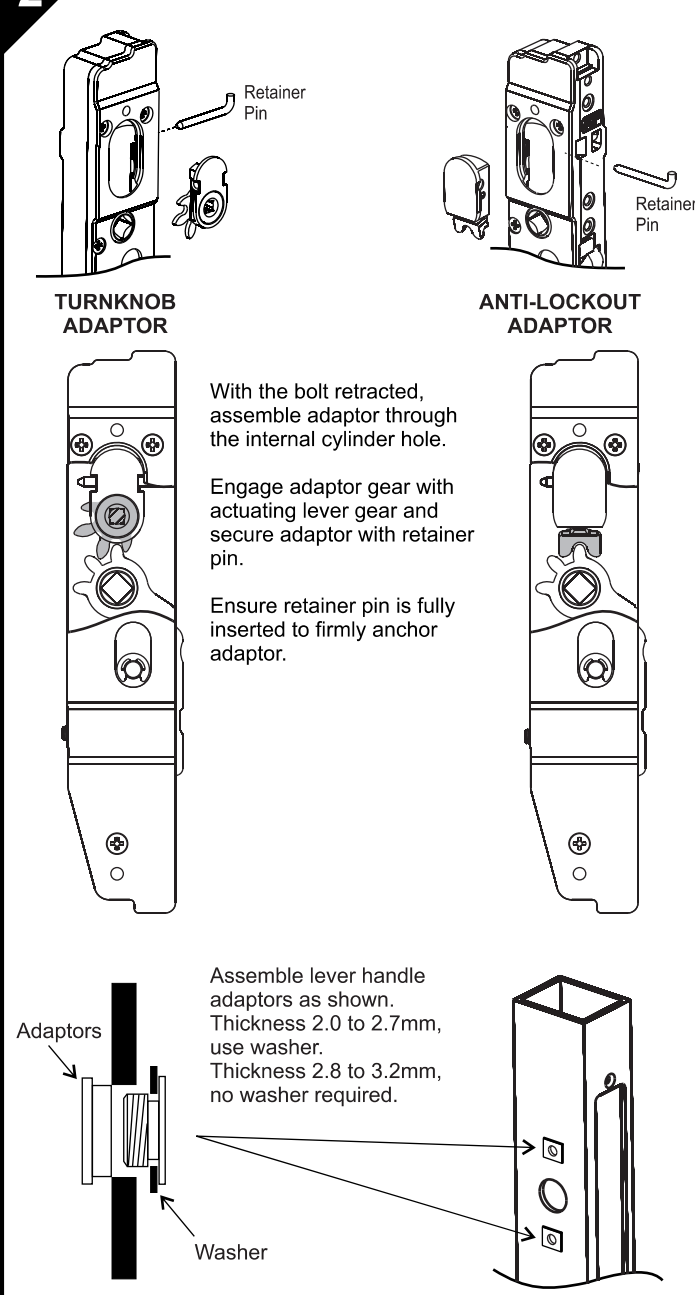

## 3 INSTALLING LOCK

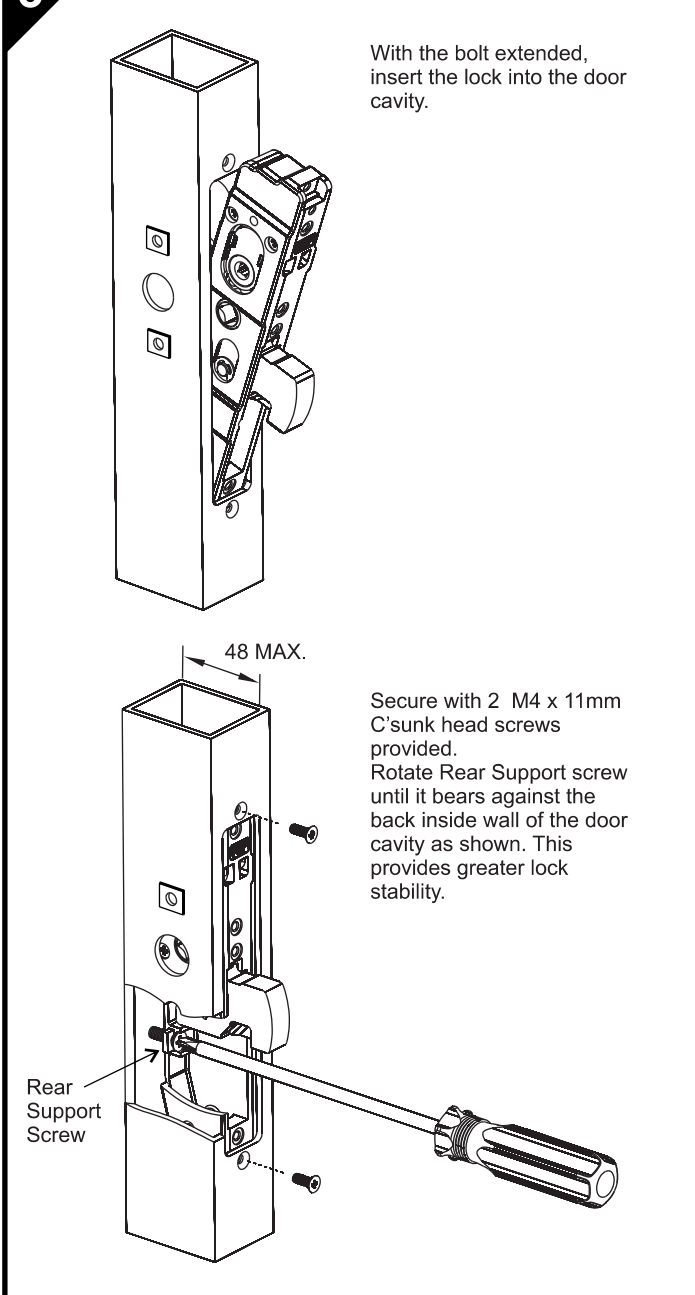

4

**FITTING ACCESSORIES**

**CYLINDER**

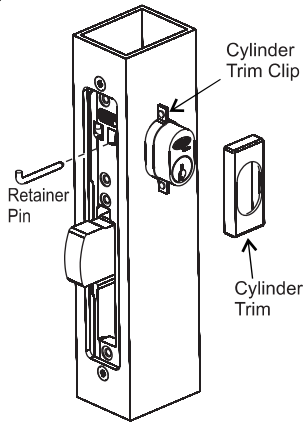

Assemble cylinder and secure with retainer pin. Ensure retainer pin is fully inserted to firmly anchor cylinder. Fit cylinder trim clip and cylinder trim.

**LEVER**

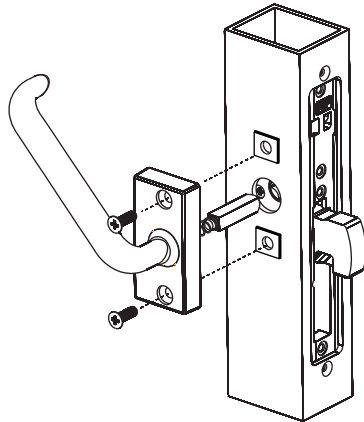

Secure Lever Handle assembly with 2 C'sunk head screws provided.

**CYLINDER TURN**

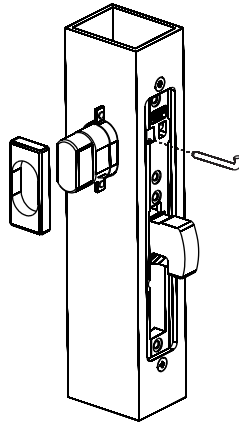

Assemble cylinder turn and secure with retainer pin. Ensure retainer pin is fully inserted to firmly anchor cylinder. Fit cylinder trim clip and cylinder trim.

**TURN KNOB**

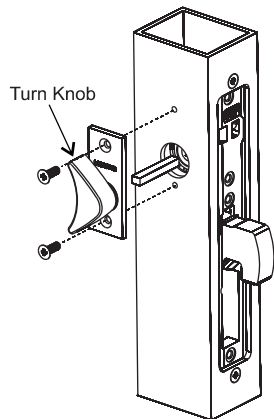

Cut connecting bar to allow 10mm to protrude from door face. Secure Turn Knob assembly with 2 C'sunk head screws provided.

**ESCAPE TURN KNOB**

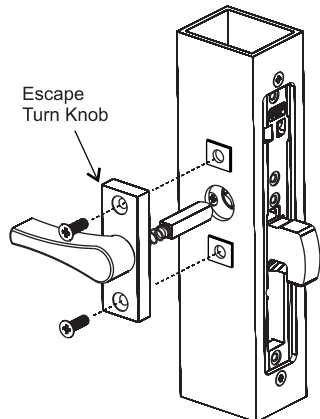

Secure Escape Turn Knob assembly with 2 C'sunk head screws provided.

**COVERPLATE**

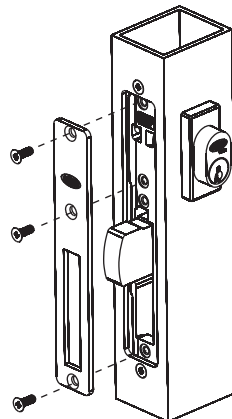

Secure Coverplate to lock with 3 M4 x 11mm C'sunk head screws provided.

5

**INSTALLING STRIKE**

**Cutting of Bolt Hole - 3540 Only**

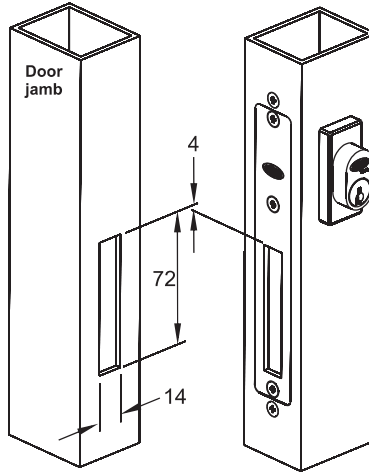

Cut a hole in door jamb as shown.

**Fitting of Sliding Door Strike - 3541 Only**

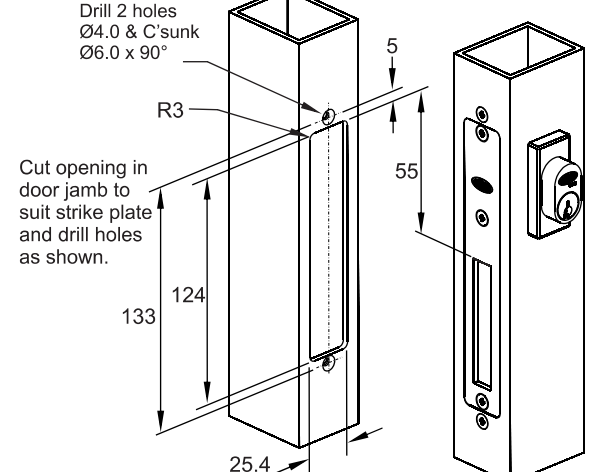

Cut opening in door jamb to suit strike plate and drill holes as shown.

Fixed Strike	22mm Bolt for 23mm Std. Backset
Self Latching Strike	28mm Bolt for 30mm Ext. Backset
Strike	28mm Bolt for 23mm Std. Backset
	36mm Bolt for 30mm Ext. Backset

**Fitting of Sliding Door Strike - 3541 Only (cont'd)**

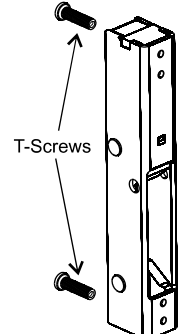

- Assemble supplied T-Screws to back of strike body. (Refer table below)
- Insert strike assembly into cavity.
- Tighten 2 T-Screws with Allen key supplied until T-screw fastens against back wall of section.
- Secure strike assembly into door jamb with 2 C'sunk head screws supplied and attach strike cover.

Depth of Section	Length of T-screw
Up to 38mm	15mm
38 to 48mm	25mm
48 to 58mm	35mm

**DO NOT USE T-SCREWS IF GLASS IS VISIBLE IN SECTION.**

**LOCKWOOD GUARANTEE**

ASSA ABLOY Australia Pty Limited ("ASSA ABLOY") warrants its Lockwood products against defects in workmanship and materials, subject to the limitations and exclusions set out in this Warranty. If, within the normal working life of a product, it is found to be defective, and none of the limitations and exclusions set out in this Warranty apply, ASSA ABLOY will supply the same or equivalent product free of charge. This is the only remedy granted by ASSA ABLOY under this Warranty. **Limitations:** All electrical and electronic components used in ASSA ABLOY's Lockwood range of products (excluding batteries) are guaranteed for a period of 12 months from the date of proof of purchase, unless stated otherwise. **Exclusions:** This Warranty does not cover: 1. Damage to or malfunction or failure of the Lockwood product caused or contributed to by: (a) improper installation or failure to follow fitting instructions; (b) improper maintenance; (c) fair wear and tear; (d) any modification or repair which has not been authorized by ASSA ABLOY; (e) use of substitute or replacement parts or cylinders other than genuine ASSA ABLOY parts or cylinders; or (f) use of batteries other than those specified by ASSA ABLOY. 2. The cost of: (a) removal and/or replacement of the Lockwood product; (b) freight and/or travelling time; (c) replacement batteries; or (d) any modification or repairs to a Lockwood product, unless authorised by ASSA ABLOY. 3. Damage to or deterioration of the plated finishes Florentine Bronze, Architectural Bronze, Polished Brass, Gold and Satin Brass, which are classified as soft finishes, and are subject to deterioration under some environmental conditions. 4. Personal injury, property damage or economic loss, however caused.

**Symmetry™ 5 Year Finish Warranty:** ASSA ABLOY Australia Pty Limited will replace five-year branded Symmetry product if within five years from the proven date of purchase it tarnishes, discolours or corrodes when properly installed and subject to no more than fair wear and tear. **Symmetry™ Everbrass® Warranty:** Everbrass® product is coated both on the exterior and interior surfaces with a lifetime anti-tarnish finish. ASSA ABLOY Australia Pty Limited will replace Everbrass® branded product if it corrodes, tarnishes or discolours when properly installed and subject to no more than fair wear and tear. This Warranty is in addition to and not in substitution for any rights of the purchaser under the Trade Practices Act and state or territory legislation.

ASSA ABLOY Australia Pty Limited, 235 Huntingdale Road, Oakleigh, VIC 3166 ABN 90 086 451 907 © 2008

An ASSA ABLOY Group brand

**ASSA ABLOY**

File name - 3540-221 - Back.ai

Colour - Black

Size - A4 (297mm x 210mm)