

PRODUCT FEM4700FS-LSS | FEM4500FS RSW

HIGH QUALITY WEATHER RESISTANT MINI ELECTRO MAGNETIC GATE LOCKING DEVICES

NEW GENERATION ELECTRIC AND ELECTRONIC LOCKING **FISH**
www.fishlocking.com.au



FEM4700FS-LSS | FEM4500FS-RSW

PRODUCT DESCRIPTION

The Electro Magnetic Mini Gate Lock FEM4700FS-LSS has a holding force of up to 380kg and the Electro Magnetic Micro Gate Lock FEM4500FS-RSW has a holding force of up to 200kg.

Both products are IP67 weather resistant with stainless steel body housings. The devices provide a dual fixing arrangement, a built-in varistor surge protection and accept both 12 and 24VDC. The Electro Magnetic Gate Locks also provide the monitoring feature "Lock Status Sensor" (LSS). The Electro Magnetic Gate Locks come with a lifetime warranty.

TECHNICAL DETAILS

PART NO.	FEM4700FS-LSS	FEM4500FS-RSW
HOLDING STRENGTH	Up to 380kg	Up to 200kg
VOLTAGE/CURRENT	Dual Voltage 12/24VDC, 12VDC=400mA 24VDC=200mA	Dual Voltage 12/24VDC, 12VDC=360mA 24VDC=180mA
MONITORING	LSS	LSS
SIZE	Magnet size: L= 220 x W= 47 x D= 30.5mm Armature plate size: L= 185 x W= 42 x D= 12mm	Magnet size: L= 162 x W= 26 x D= 31mm Armature plate size: L= 130 x W= 30 x D= 8.7mm

PRODUCT FEATURES

- Lock Status Monitoring Sensor (LSS)
- Stainless 304 steel body housing
- Weather resistant IP67
- Lifetime warranty
- CE/C-Tick
- Guaranteed no residual magnetism

PRODUCT DIMENSIONS AND INSTALLATION

FEM4700FS-LSS

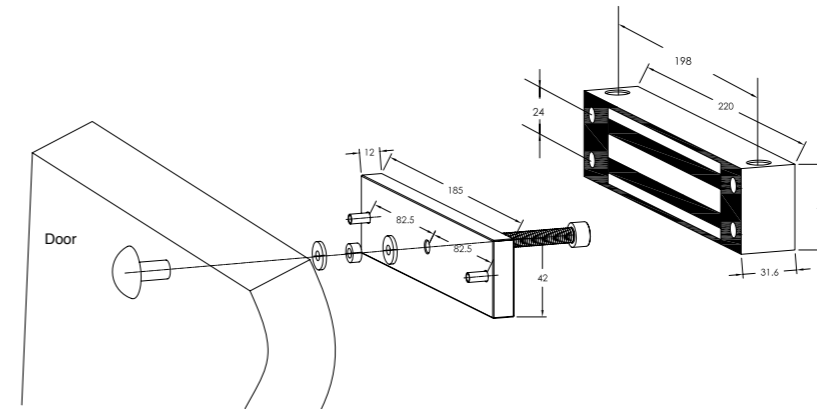

FEM4500FS-RSW

