

FLUSH PULL PASSAGE KIT**Product code: 8107**

Due to the press fit nature of this hardware, care should be taken when marking the door for mortices. Please recheck all details prior to drilling.

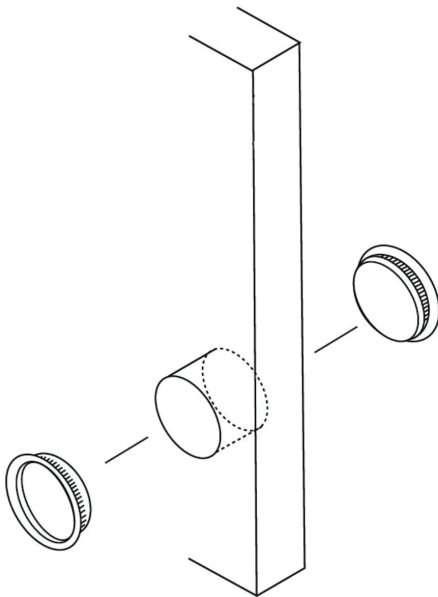

1. To fit the flush pulls, mark the face of the door each side for drilling a 48mm diameter hole at the required height. We recommend using a 48mm hole saw. For clean cut-outs, drill from both sides, meeting in the middle of the door.
2. Clear the holes of any loose saw dust and evenly press fit the flush pulls on either side of the door.

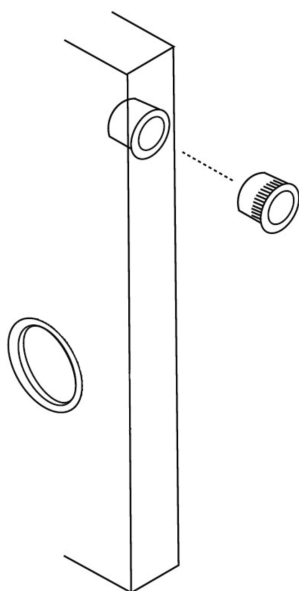

3. To fit the edgepull, mark the position on the door at the required height. Drill a 25mm (1") diameter hole through the door edge to a depth of at least 25mm. We recommend marking the drill at 25mm to achieve this depth.
4. Clear the hole of any loose saw dust and press the edgepull evenly into the hole with the larger inside lip pointing towards the bottom. For a superior fixing of the edgepull, use a construction adhesive when fitting.