

GALAXY INTEGRATED PRIVACY SET

Product codes:

7205 | 7215 | 7225 | 7235

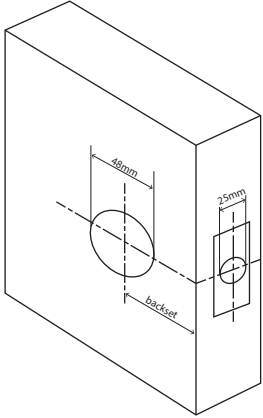

1. Measure the door thickness and mark the centre at the desired height for the latch.
2. Drill a 25mm (1") diameter hole through the door edge to a depth of at least 80mm. Ensure this hole is square to the door.
3. Mark the face of the door each side for drilling a 48mm diameter hole. The centre of the 48mm hole will need to be 60mm from the door edge (backset). We recommend using a 48mm hole saw. For clean cut-outs, drill from both sides, meeting in the middle of the door.

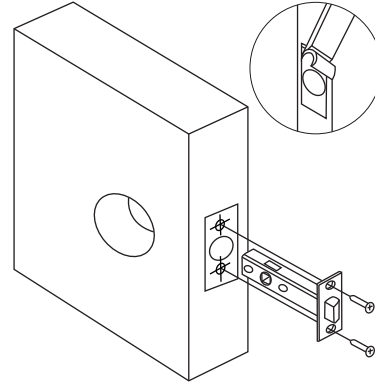

4. To change the handing of the latch, remove the outer faceplate, pull and rotate the latch tongue 180 degrees.
5. Insert the latch, scribe around the faceplate, remove, then chisel out recess to enable the latch faceplate to sit flush with the door edge.
6. Remove any loose saw dust and insert the latch, attach the faceplate and secure with the wood screws provided.

Note: To change the handing of the latch, pull out the tongue and then twist to rotate the position of the tongue.

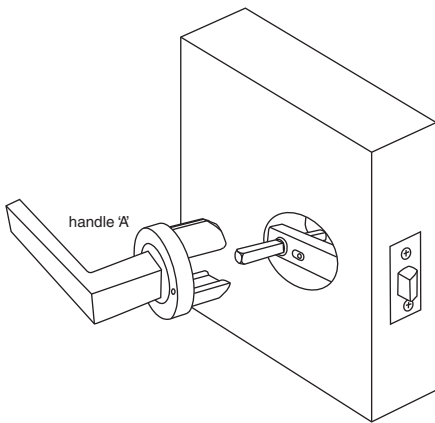

7. Remove the o-ring from the spindle. Insert the spindle into the latch so an even amount protrudes on each side of the door and slide the o-ring back onto the spindle.
8. Insert handle 'A' with rapidFIT® attached onto the spindle in the 48mm hole and press against the door.

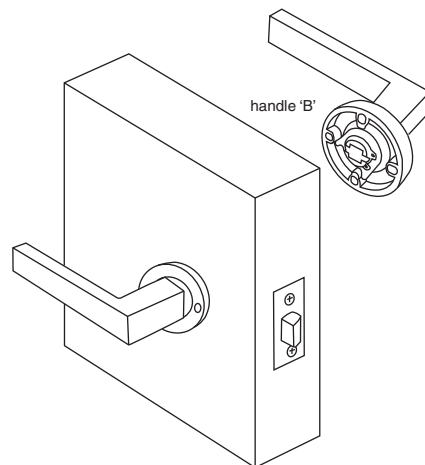
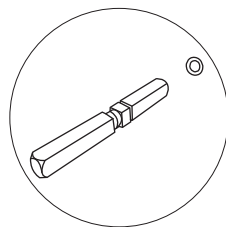

9. Insert 'handle B' over the spindle. Ensure the handles are straight before securing the through fixing screws.
10. Press the rose cover onto the handle and ensure the integrated privacy pin hole is lined up. Tighten the grubscrews on the side of the levers onto the spindle for each side of the door. For the square rose (Galaxy Elite) press on the rose cover and tighten the grubscrew on the side of the rose.
11. Insert the integrated privacy pin through the rose and into the threaded slot on the latch.

Note: The grubscrews may need a re-tighten after a bedding-in period. We recommend medium strength thread-lock to be used. Windsor code: 1276

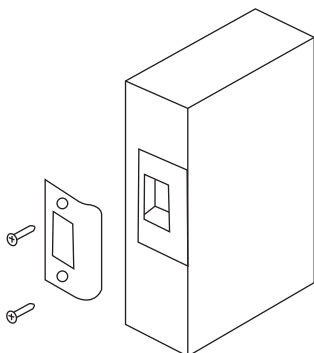

12. Close the door against the frame and mark the latch position for fitting of the striker.
13. Router or chisel so the striker fits flush, allowing for the plastic dustbox behind the striker.
14. Secure the striker with the wood screws provided. Test the door and if necessary, adjust the striker anti-rattle tab to take up any rattle.

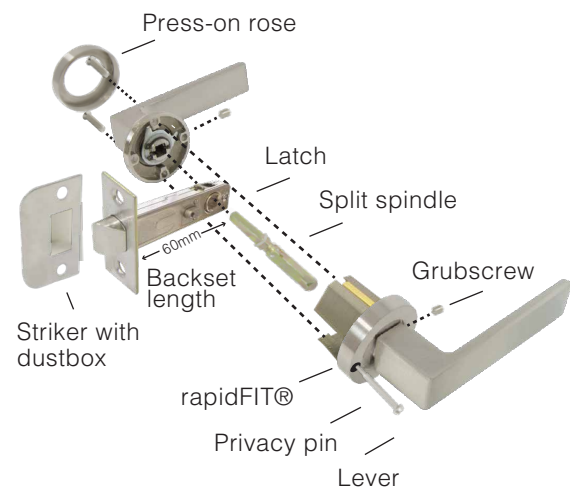

GALAXY INTEGRATED PRIVACY SET - rapidFIT REMOVED

Product codes:
7205 | 7215 | 7225 | 7235

To view an easy to follow how-to video for installing this product visit windsorhardware.co.nz/installation.

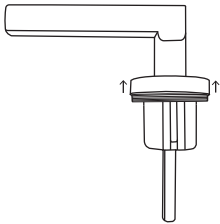

- Remove the rose cover from the handle.
For the round roses unscrew rose cover.
For the square roses (Elite) unscrew the grub screw on the side of the rose and pop off the rose cover.

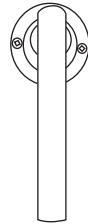

- Remove the screws with the red screw head.

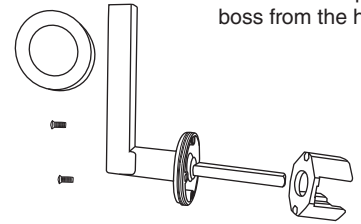

- Remove the rapidFIT boss from the handle.

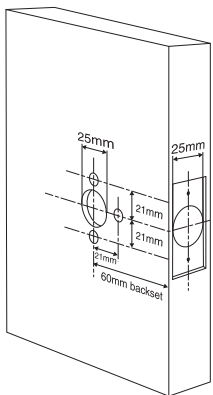

- Measure the door thickness and mark the centre of the door edge at the desired height for the latch.
- Drill a 25mm (1") diameter hole through the door edge to a depth of at least 90mm. Ensure this hole is square to the door.
- Mark the face of the door each side for drilling a 25mm diameter spindle hole. The centre of the spindle hole will need to be 60mm from the door edge (backset). Mark two screw holes at 21mm above and below the centre of the spindle hole. Mark one 6mm privacy pin hole at 21mm from the centre of the spindle hole towards the latch. Drill the holes to 6mm diameter. For clean cut-outs, drill from both sides, meeting in the middle of the door.

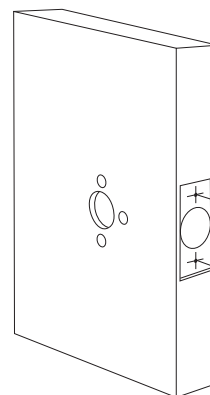

- Insert the latch, scribe around the faceplate, remove, then chisel out recess to enable the latch faceplate to sit flush with the door edge.

- Remove any loose saw dust, insert the latch and secure it with the wood screws provided.

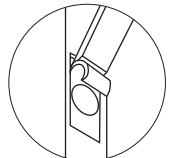

Note: To change the handing of the latch, pull out the tongue and then twist to rotate the position of the tongue.

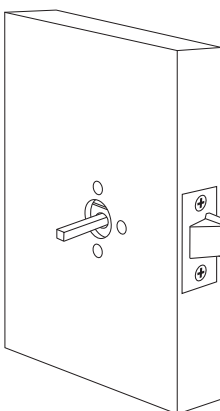

- Pull off the rose covers. Remove the o-ring from the spindle, insert the spindle into the latch so an even amount protrudes on each side of the door and slide the o-ring back onto the spindle.

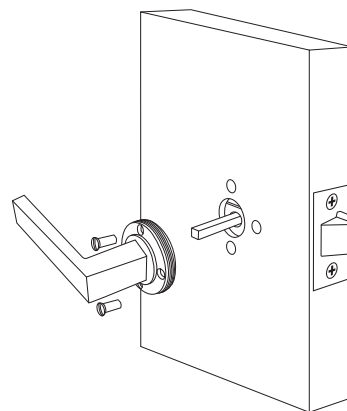
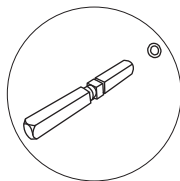

- Insert the blind nuts through the face of the rose at two vertical positions. Slide the handle over the spindle and press against the door.

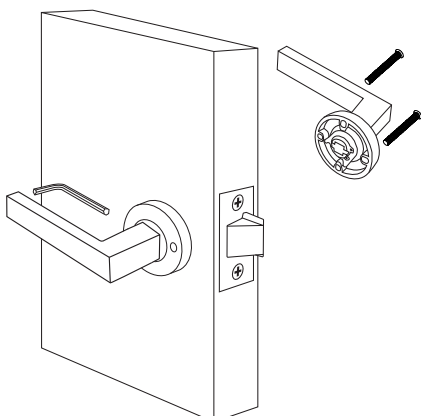

- Slide the handle on the opposite side of the door over the spindle and press against the door. Insert the long bolts through the face of the rose and tighten them into the blind nuts.

- Press the rose covers onto the handles and ensure the integrated privacy pin holes are lined up. Tighten the grub screws on the side of the levers onto the spindle for each side of the door. Tighten the grub screws on the side of the rose covers onto the roses.

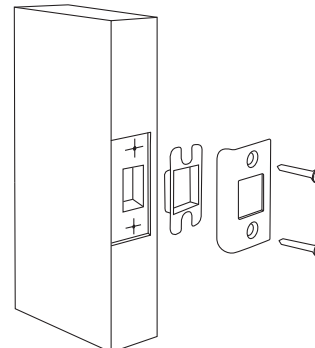

- Close the door against the frame and mark the latch position for fitting of the striker.

- Router or chisel so the striker fits flush, allowing for the plastic dustbox behind the striker.

- Secure the striker with the wood screws provided.

- Adjust the anti-rattle tab on the inside of the striker if necessary to ensure a firm close of the door.

Note: The grub screws may need a re-tighten after a bedding-in period.
We recommend medium strength thread-lock to be used.
Windsor code: 1276