

Libi™ Digital Lever Keyed - User Guide

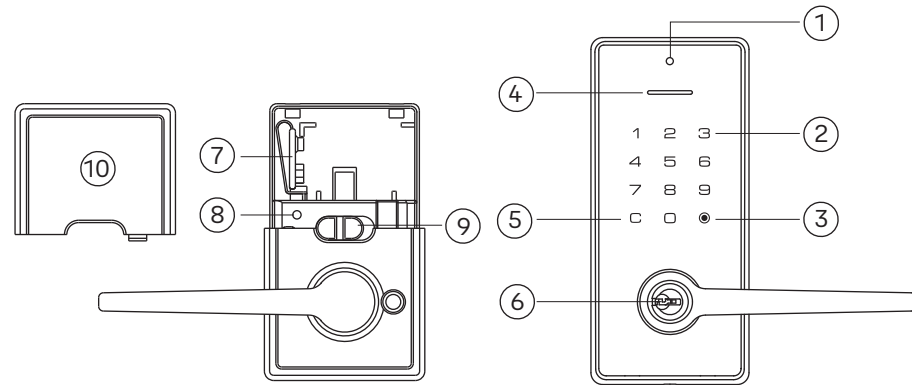

- NOTE**
- Do not use any chemicals or add any lubricants when cleaning the lock, to avoid damaging the panel and coating.
 - 9V Alkaline batteries are recommended to maintain stable and prolonged power.

Operational interface



- Light sensor**
Proximity to wake up the interface.
- Number buttons**
Used to enter user codes.
Each code must be 4 to 10 digits in length.
- Confirm button**
For function setup.
- Indicator light**
Red and green light display.
- Cancel button**
Numbers entered incorrectly can be deleted.

- Cylinder**
To be locked and unlocked with the key.
- Battery holder**
Uses 9V Alkaline batteries.
- Programming button**
Restore default setting/Programming mode.
- Slider**
Switch passage mode.
Stays unlocked, allowing entry without a key or code.
- Battery cover**
Push it upward and outward to replace the batteries.

Operating instructions

Operation Indicator Sounds and Lights

Meaning	Lights	Sounds
Successful Operation	Flashes Green Once	1 Beep
Successful Programming	Flashes Green Twice	2 Long Beeps
Default Setting Restored	Flashes Orange 3 Times	3 Long Beeps
Operation Error	Flashes Red 3 Times	3 Beeps
Programming Error	Flashes Red 5 Times	5 Beeps
Code Input Error 5 times/ System Lockdown	Flashes Red 5 Times	5 Long Beeps
Locked	Flashed Red Once	1 Long Beep
Unlocked	Flashed Green Twice	2 Beeps
Low Battery Power	Flashes Red 10 Times	10 Long Beeps
In Programming Mode	Flashes Orange Slowly	None

Programming



- NOTE**
- The programming button is located on the interior chassis below the battery holder.
 - During programming, if no button is pressed within 5 seconds, the system will time out and you will need to restart the procedure.
 - If a programming code is created, the programming button will only be used for restoring the lock to default settings. The code must be used to start programming mode.
 - For new installations, or when a lock is restored to default settings, you must use the programming button to start the programming mode.

Add User Code (UC)	Programming Button → 1 → ● → enter UC → ● NOTE : Up to 70 User Codes can be saved. User Codes should be 4 to 10 digits in length.
Delete Individual User Codes (UC)	Programming Button → 2 → ● → enter UC → ● → Re-enter UC → ●
Delete All User Codes (UC)	Programming Button → 3 → ●
Add Programming Code (PC)	Programming Button → 4 → ● → enter PC → ● NOTE : • The Programming Code can not be the same as any User Code and will not unlock the lock. • Please note once a Programming Code is enabled, the programming button is disabled and can only be used to factory reset the lock. • To program the lock when the Programming Code is enabled, instead of pressing the programming button, enter the Programming Code and press the confirm button to enable the Programming Code.
Set Auto-Lock Time Delay	Programming Button → 6 → ● → 1-99 seconds → ●
Toggle Mute On/Off (default Off)	Programming Button → 7 → ●
Enable/Disable Vacation Mode	Programming Button → 8 → ● NOTE : If enable vacation mode, all User Codes are still in the memory, but all invalid until disable vacation mode.
Add One-time User Code	Programming Button → 9 → ● → enter one-time UC → ● NOTE : Up to 5 One-time User Codes can be saved. One-time User Codes should be 4 to 10 digits in length.
Restore Default Setting Press programming button for more than 5 seconds, and the programming is reset back to the original factory codes once you hear 3 long beeps. NOTE : After restoring default setting, all User Codes will be deleted and all programming will be changed to factory settings.	

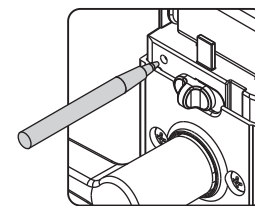

Programming notes

Add User Code

- Up to 70 User Codes can be saved. User Codes should be 4 to 10 digits in length.
- For security reasons, the first 4 digits of each User Code must be unique.
- For example, you are unable to program a User Code 1-2-3-4-5 as well as a User Code 1-2-3-4-6.
- Press the lock button before entering your code to light up the keypad at night.

Delete All User Codes

- Keypad locking function will be disabled when User Codes are deleted. The lock can only be operated manually by key during this time.

Enable/Disable Programming Code

- Optional: A Programming Code enables you to make programming changes without needing to access the programming button.
- One Programming Code can be saved and should be 4 to 10 digits in length.
- The Programming Code can not be the same as any User Code and will not unlock the lock.
- To program the lock when the Programming Code is enabled, instead of pressing the programming button, enter the Programming Code and press the confirm button to enable the Programming Code.
- Repeat the programming steps to disable the Programming Code. Please note once a Programming Code is enabled, the programming button is disabled and can only be used to factory reset the lock.

Set Auto-Lock Time Delay

- Press the keypad number that corresponds to your time delay preference, choosing between 1 and 99 seconds.

Toggle Mute On/Off

- LED status indicator will still function once audio is disabled. Repeat the programming steps to enable the audio.

Enable/Disable Vacation Mode

- When vacation mode is enabled, all electronic functions will be disabled as well.
- The door must be locked or unlocked manually with the key.
- Repeat the programming steps to disable vacation mode.

Add One-Time Use Code

- Up to 5 One-time User Codes can be saved. One-time User Codes should be 4 to 10 digits in length.
- The One-Time User Code will be deleted automatically after it is used.
- The same One-Time User Code can be created again after it's used.

Factory Reset

- After restoring default setting, all User Codes will be deleted and all programming will be changed to factory settings.

Slider functions - choosing a mode



Auto-lock mode

Key or code is needed for entry from the outside.
Default auto-lock is 5 seconds.



Passage mode

Stays unlocked, allowing entry without a key or code.

Trouble shooting

Problem	Possible Cause	Corrective Action
After the installation is complete and the batteries are in place, none of the buttons are responsive. (No sound, and no backlight)	Issues with batteries or the wiring.	Replace the batteries or make sure the batteries are installed correctly. Please check whether the cable from the interior lock unit is connected correctly.
The door cannot be locked.	The slider is located in the function : Passage	Manually switch the slider function position.
After installing the lockset and batteries, the door can't be locked and three short beeps are emitted when you press any button.	The battery doesn't have enough energy to supply for the lock.	Replace the battery.

